

America's Greatest Rail Disaster—E. B. Heineman

# RAILROAD STORIES

APRIL  
**15**¢

ALL COMPLETE

ILLUSTRATED

*He Was a Hell-Roaring Hogger  
on the Old Santa Fe*

## LONGHORN LANNIGAN

By Ed Samples



NRA  
CODE

# GET AFTER SORE THROAT WITH LISTERINE

*Safe antiseptic brings quick relief, also fights colds. Kills bacteria in mouth and throat*

Don't put up with the pain of ordinary sore throat. It can so often be quickly relieved by gargling with full strength Listerine, the safe antiseptic.

After this easy treatment, you will be delighted to find how much better your throat feels. That raw, burning, constricted sensation is gone.

Where the throat is seriously inflamed as the result of chronic infection of the tonsils, call a competent physician. Listerine can be of small help in such cases.

Fortunately for Mankind, however, most cases of sore throat are mild infections heralding the coming of a cold. Bacteria multiply in the throat, irritating its membranes, then move either up-

ward into the nose, or downward to the bronchial tubes.

Doctors know, and you undoubtedly realize, the importance of keeping such bacteria under control—of killing as many as possible before they move to near-by tissues. You can see the advantage of using Listerine, notable for its germ-killing power. Reductions of bacteria in the mouth and throat ranging to 98.7% have been noted after the use of this safe antiseptic.

Even more interesting is this practical proof of Listerine's germ-killing ability: Those who gargled with Listerine twice a day caught fewer colds and less severe colds than those who did not gargle.

Listerine, to many, is that "ounce of prevention" so useful in combating Mankind's greatest nuisance and Mankind's greatest menace—the common cold. Keep a bottle of Listerine handy in home and office and use it systematically. Lambert Pharmacal Company, St. Louis, Mo.

**LISTERINE kills germs  
—yet is SAFE**



**S**quirrel rifles cracked in the Kentucky forests to spread Crab Orchard's reputation for good living



OVER at the hotel in Crab Orchard, young marksmen from the surrounding country used to find a ready market for squirrels, if they were plump and tender.

For "quality folk" from Louisville, down through the Cumberland valley, and up beyond Cincinnati journeyed to that quiet little town, to "take the waters" of its famous limestone spring, and enjoy the old-fashioned southern eatables and drinkables of its picturesque hotel.

Among the gentry who gathered there were naturally some excellent judges of Bourbon. And those critical gentlemen went away not only with pleasant memories of luscious squirrel pie, or 'possum roasted with sweet potatoes, but also of a marvelously mellow

local whiskey, named for the town where it was made.

Gradually the reputation of Crab Orchard Whiskey spread throughout the Blue Grass country—as tales of its goodness, or perhaps a jug for juleps, were carried home. But for almost sixty years, Crab Orchard remained a local favorite.

Then came the confused days after prohibition.

People wanted something hard to find. They wanted a straight whiskey—made the good old-fashioned way—smooth and pleasing to taste—and they wanted a low price.

And because that was exactly what Crab Orchard offered, it became *America's fastest-selling straight whiskey*. Anywhere from

Broadway to the Golden Gate, you will find it the popular favorite today.

Made in old Kentucky  
Straight as a string  
Smooth and satisfying to taste  
Sold at a popular price



This Emblem  
Protects You

**Crab Orchard**

AMERICA'S FASTEST-SELLING STRAIGHT WHISKEY

© 1935, The American Medicinal Spirits Co., Inc., Louisville, Ky.

This advertisement is not intended to offer alcoholic beverages for sale or delivery in any state or community where the advertising, sale or use thereof is unlawful.

15c  
a Copy

# RAILROAD STORIES

\$1.50  
a Year

APRIL, 1935  
Vol. XVII, No. 1



Formerly RAILROAD MAN'S MAGAZINE—Title Registered in U. S. Patent Office

## FICTION AND TRUE TALES

Blanket Stiffs (Short Story).....	Dave A. Martin	7
Slippery Buck's Ballroom Run (Short Story).....	James W. Earp	20
Red Rails (True Tale).....	Neill James	45
Beef Tallow and Limburger (True Tale)...	"Highball John" Burns	53
Longhorn Lannigan (Novelette).....	Ed Samples	56
Rights Over Everything (Short Story).....	Bozo Texino	99
Damnhobo (Short Story).....	E. S. Dellinger	112
Interference (Short Story).....	Griff Crawford	123

## SIX POPULAR DEPARTMENTS

The Sunny Side of the Track....	29	By' the Light of the Lantern..	80
International Engine Picture Club	38	On the Spot.....	129
The Boomer Trail.....	54	The Model Trading Post...	140

## ILLUSTRATED FEATURES

America's Greatest Rail Disaster.....	E. B. Heineman	16
Highway Robbery.....	George L. Phillips	30
Thirty-six Miles in Three Days.....	Thomas F. Sisk	33
House of David Railroad.....	Freeman H. Hubbard	34
Hints on Locomotive Photography.....		38
Locomotives of the Lehigh Valley Railroad.....		88
Into the Dark Continent.....	Charles Frederick Carter	91
Who's Who in the Crew (J. H. McKinley).....	Stookie Allen	98
The Month of April in Railroad History.....		108
Build a Model Wedge Plow.....	Leonard Cooper	139

THE FRANK A. MUNSEY COMPANY, Publisher, 280 Broadway, New York City  
WILLIAM T. DEWART, President R. H. TITHERINGTON, Secretary

MESSAGERIES HACHETTE  
3, La Belle Sauvage, Ludgate Hill, London, E.C.4

PARIS: HACHETTE & CIE.  
111 Rue Réaumur

Published every month and copyright, 1935, by The Frank A. Munsey Company. Single copy, 15 cents in United States; 20 cents in Canada. By the year, \$1.50 in United States, its dependencies, Mexico, and Cuba; Canada, \$2.00. Other countries, \$3.00. Remittances should be made by check, express money order or postal money order. Currency should not be sent unless registered. Entered at the post office, New York, N. Y., as second class matter November 15, 1929, under the Act of March 3, 1879. Entire contents protected by copyright; must not be reprinted without publishers' permission. Copyrighted also in Great Britain.

Manuscripts submitted to this magazine should be accompanied by sufficient postage for their return if found unavailable. The publisher can accept no responsibility for return of unsolicited manuscripts.

# NEW LOW PRICES

## GOOD YEAR

### Firestone - Goodrich

#### U.S. AND OTHER TIRES

# SAVE ON TIRES NOW

# \$2.15

29 x 4.40 - 21



# \$2.45

28 - 4.75 - 19

**Why Pay High Prices for Tires?**  
 Save money on all standard brands, reconstructed by the special Adamite scientific process. Adams tires are fully guaranteed to give best of service under severest road conditions for 12 full months and are backed by the vast financial resources of this well-known company. Now is the time to buy, before prices advance.

BALLOON TIRES				CORD TIRES		
Size	Rim	Tire	Tube	Size	Tire	Tube
29x4.40-21		\$2.15	\$0.85	30x3	\$2.25	\$0.65
29x4.50-20		2.35	0.85	30x3 1/2	2.35	0.75
30x4.50-21		2.40	0.85	31x4	2.95	0.85
28x4.75-19		2.45	0.95	32x4	2.95	0.85
29x4.75-20		2.50	0.95	33x4	2.95	0.85
29x5.00-19		2.85	1.05	34x4	3.25	0.85
30x5.00-20		2.85	1.05	32x4 1/2	3.35	1.15
28x5.25-18		2.90	1.15	33x4 1/2	3.45	1.15
29x5.25-19		2.95	1.15	34x4 1/2	3.45	1.15
30x5.25-20		2.95	1.15	30x5	3.65	1.35
31x5.25-21		3.25	1.15	33x5	3.75	1.45
28x5.50-18		3.35	1.15	35x5	3.95	1.55
29x5.50-19		3.35	1.15	<b>Heavy Duty TRUCK TIRES</b>		
30x6.00-18		3.40	1.15	Size	Tire	Tube
31x6.00-19		3.40	1.15	30x5	\$4.25	\$1.95
32x6.00-20		3.45	1.25	32x6	7.95	2.75
33x6.00-21		3.65	1.25	36x6	9.95	3.95
31x6.50-19		3.60	1.35	34x7	10.95	3.95
32x6.50-20		3.75	1.35	38x7	10.95	3.95
34x7.00-20		4.60	1.65	36x8	12.45	4.25
35x7.00-21		4.60	1.65	40x8	15.95	4.95
				<b>Heavy Duty Truck Balloons</b>		
				Size	Tire	Tube
				7.50-20	\$6.95	\$3.75
				8.25-20	8.95	4.95
				9.00-20	10.95	5.65
				9.75-20	13.95	6.45

**12 MONTH WRITTEN GUARANTY BOND WITH EACH TIRE**

**ALL TUBES GUARANTEED BRAND NEW**

**HOW TO ORDER**  
 Send \$1 deposit with each tire ordered (\$4 with each Truck Tire.) Balance C.O.D.  
 If you send cash in full deduct 5%.  
 Remember — 12 months' guaranteed service or replacement at half price.

**DEALERS WANTED**

**ALL OTHER SIZES**

**ADAMS TIRE & RUBBER CO., Dept. E-56**  
 2515 South Michigan Ave., Chicago, Illinois

*In answering this advertisement it is desirable that you mention RAILROAD STORIES.*

# Sick Kidneys need this healing oil

Just as oils and ointments relieve burns, so does the santalwood oil in Santal Midy soothe and relieve irritations of kidneys and bladder. Santal Midy for nearly 100 years has given relief to such symptoms of bladder and kidney disorders as painful joints, headaches, backaches, and getting up nights. Santal Midy costs a few cents more than harsh pills or drugs—but the mildness, safety and comfort you get is well worth it. Any druggist can supply you.



Don't Neglect BACK ACHES

## SANTAL MIDY for the KIDNEYS and BLADDER

How to make 33 electrical devices **ONLY ONE DIME!**

Secret locks • Electro magnets  
Telegraph sets • Buzzers

Complete scientifically correct instructions for making 33 interesting electrical devices that will really work. Also simple, illustrated description of principles of electricity and dry batteries.

96 pages—illustrated

Any man or boy who likes to make things needs this book. Write for your copy today. Send 10 cents (coin or stamps) to Dept. R.S. 354 Room 1328, National Carbon Company, Inc., 30 East 42nd St., New York, N. Y.



## GOVT. JOBS

**SALARY TO START \$105 to \$175 MONTHLY**

**MEN**  
Age Range 18 to 50

**WOMEN**  
Age Range 18 to 50

Ry. Mail Clerk  
P. O. Laborer  
R. F. D. Carrier  
Special Agent  
Customs Inspector  
City Mail Carrier  
P. O. Clerk  
Matron  
Immig't Inspector  
Typist

POSTMASTER  
Seamstress  
Auditor  
Stenographer  
U.S. Border Patrol  
Telephone Opr.  
Watchman  
Meat Inspector  
Statistical Clerk  
File Clerk

Instruction Bureau, Dept. 685-A, St. Louis, Mo.  
Send me FREE particulars "How to Qualify for Government Positions" marked "X". Salaries, locations, opportunities, etc. ALL SENT FREE.

Name.....  
Address.....



## High School Course in 2 Years

You can complete your High School education at home—in 2 years or less. Course meets all requirements for entrance to college and leading professions. Standard H. S. texts supplied. Diploma awarded. Full credit for H. S. subjects already completed. Send for Free Bulletin TODAY. No obligation.

AMERICAN SCHOOL, Dept. H-41, Drexel at 58th, Chicago

## BE TALL

Your Height increased in 14 days or money back! The amazing Stebbing System soon brings 3-5 inches increase, new "pep" and energy. A valuable Health Course and "Success and Popularity" Course included FREE with System, sent complete for \$2.00. Send for convincing Free Book with testimonials and Guarantee in plain sealed envelope. **WRITE NOW TO—**

**STEBBING SYSTEM**  
Dept. M. S. 1, FOREST HILLS, NEW YORK



**GIVEN Sweet Toned VIOLIN**  
Handsome finish, highly polished. Set of strings and bow included. SEND NO MONEY. Just name and address. WE TRUST YOU with 27 packs of Garden Seeds to sell at 10c a packet. When sold send \$2.70 collected and we will send Violin Outfit and Instruction Book. Years to play in 5 minutes. No more money to pay... EXTRA-\$100 in BIG PRIZES. You may win. Write for seeds today. A Post Card will do. LANCASTER COUNTY SEED CO., Station 319, PARADISE, PA.

## EARN MONEY with this WONDERFUL NEW INVENTION

BLOW TORCH & SOLDERING IRON IN ONE!  
AGENTS! Make quick, steady PROFITS with amazing NEW invention—sells on "flash" demonstration. Main or side line, part or full time. Opens big, new market. WRITE—get established for exclusive territory. Hurry! Justrite Mfg. Co., 2061 Southport, Dept. 2704, Chicago

## NOW \$2000.00 LIFE & ACCIDENT PROTECTION AT ACTUAL COST

Amazing New "\$1.00 PER MONTH" LIFE Plan Pays up to \$2000.00 for NATURAL or ACCIDENTAL DEATH. Issued by a big RELIABLE, STATE-CHARTERED COMPANY. Benefit does NOT decrease as you grow older. Age limits 11 to 80. NO MEDICAL EXAMINATION. Certificate sent on FREE APPROVAL, without cost or obligation. Just send your name, address, age and Beneficiary's name. PAY NOTHING.

WRITE INTERSTATE AID ASS'N, Dept. M-2, 75 E. Wacker, Chicago.

## No JOKE TO BE DEAF

Every deaf person knows that—Mr. Wray made himself hear his watch tick after being deaf for twenty-five years, with his Artificial Ear Drums. He wore them day and night. They stopped his head noises. They are invisible and comfortable, no wires or batteries. Write for TRUE STORY. Also booklet on Deafness.

**Artificial Ear Drum**  
THE WAY COMPANY  
726 Hofmann Bldg. Detroit, Michigan

## LINCOLN AND INDIAN HEAD PENNIES WANTED

WE PAY UP TO \$2 EACH IF MORE THAN 11 YEARS OLD

and up to \$500 for certain U. S. Cents

Send 10c. today for 16 page fully illustrated catalog

NATIONAL COIN CO.  
Box 731SM. MILWAUKEE, WIS.

## GIVEN SPORT WATCH

Perfect time keeper. Long tonneau shape, chrome finish engraved case. Newest linked wrist band. It's Dandy. Send for two 27 packet collections of Garden Seeds. Sell at 10c a pack. Remit money collected, then watch is yours. **Positively No Extra Money to Pay. SEND NO MONEY NOW.** Just name and address, Extra-\$100 in BIG PRIZES. You may win. Write for seeds today. A Post Card will do. We Trust You.

LANCASTER COUNTY SEED CO. Sta. 393, PARADISE, PA.



# I'LL TRAIN YOU AT HOME

*In Your Spare Time For A*

## GOOD RADIO JOB

Mail the coupon now. Get the facts about Radio—the field with a future. N. R. I. training fits you for jobs in connection with the manufacture, sale and operation of Radio equipment. It fits you to go in business for yourself, service sets, operate on board ships, in broadcasting, television, aviation, police Radio and many other jobs. My FREE book tells how you quickly learn at home in spare time to be a Radio Expert.

### Many Radio Experts Make \$40, \$60, \$75 a Week

Why struggle along in a dull job with low pay and no future? Start training now for the live-wire Radio field. I have doubled and tripled salaries. Hundreds of successful men now in Radio got their start through N. R. I. training.

### Many Make \$5, \$10, \$15 a Week Extra in Spare Time While Learning

Hold your job. I'll not only train you in a few hours of your spare time a week, but the day you enroll I start sending you Extra Money Job Sheets which quickly show you how to do Radio repair jobs common in most every neighborhood. I give you Radio Equipment for conducting experiments and making tests that teach you to build and service practically every type of receiving set made. Cleo T. Retter, 30 W. Beechwood Ave., Dayton, Ohio, wrote: "Working only in spare time, I made about \$1,500 while taking the Course."

### Find Out What Radio Offers

My book has shown hundreds of fellows how to make more money and win success. It's FREE to any ambitious fellow over 15 years of age. Investigate. Find out what Radio offers you. Read what my Employment Department does to help you get into Radio after graduation, about my Money Back Agreement, and the many other N. R. I. features. Mail the coupon in an envelope, or paste it on a 1c. post card TODAY.

J. E. SMITH, President, Dept. 5DK  
National Radio Institute, Washington, D. C.



J. E. SMITH, President National Radio Institute  
The man who has directed the Home-Study Training of more men for the Radio industry than any other man in America.

## HERE'S PROOF that my training pays



Now Owns Own Business "If I had not taken your Course I would be digging ditches instead of running my own business. One week I made \$75 on repairing alone, and this doesn't count sales. If a fellow wants to get into Radio, N. R. I. is the starting point." R. S. Lewis, Modern Radio Service, Pittsfield, Ill.



Spare Time Jobs Earn \$15 a Week "I have no trouble getting Radio work. I have the reputation of being the best Radio man in town, and average \$15 to \$20 a week for spare time only." G. Bernard Crox, 151 Washington St., Bronson, Michigan.



Owes His Success to Radio Training "Since 1929 I have earned my living in Radio. I owe my last three jobs to N. R. I. I am now in the main control room of one of the large broadcasting chains." Serge A. De Somov, 1516 Library Ave., New York City.



J. E. SMITH, President, Dept. 5DK  
National Radio Institute, Washington, D. C.

Dear Mr. Smith: Without obligating me, send your book which points out the spare time and full time job opportunities in Radio and your 50-50 method of training men at home in spare time to become Radio Experts.

(Please print plainly)

NAME..... AGE.....  
ADDRESS.....  
CITY..... STATE.....





# Classified Advertising

## The Purpose of this Department

is to put the reader in touch immediately with the newest needfuls for the home, office, farm, or person; to offer, or seek, an unusual business opportunity, or to suggest a service that may be performed satisfactorily through correspondence. It will pay a housewife or business man equally well to read these advertisements carefully.

## Classified Advertising Rates in The Munsey Magazines

Line Rate	
All-Story	\$3.50
THE ARGOSY COMB'S	Line Rate
The Argosy	\$2.75
Det. Fic. Weekly	1.75
Less 2% cash discount	
Railroad Stories	.80
Combination Line Rate	
Less 2% cash discount	

Classified Advertising forms close on the first day of second month preceding publication.

10% discount allowed on six consecutive insertions. Discounts to be earned must be deducted from the sixth insertion.

### AGENTS AND SALESMEN

**SALESMAN-DISTRIBUTOR WITH CAR. SELL DRUG, HARDWARE, GARAGES, ETC. NEW TEN CENT ITEM. QUICK SELLER. SURE REPEATER. IDEAL FOR TRUCK JOBBERS. FEARLESS WATER-PROOF CEMENT CO., 2744 DODIER ST., ST. LOUIS, MO.**

**SELL SANFORIZED SUMMER SUITS. NO COMPETITION. FREE OUTFIT SUIT FURNISHED. BONUS. POPULAR STYLES \$4.95 AND \$2.00 COMMISSION AND UP. SERVICE, F-1615 N. DAMEN, CHICAGO.**

**SELL PROCESS RAISED PRINTING—\$3.95 Thousand, with Free Cut Service. Worth \$6.00. Nothing like it! Commission \$1.00. Experience unnecessary. Outfit furnished free. UNITED ENGRAVERS, R-8 South Dearborn, Chicago.**

**AMBITIOUS MEN—Make \$5 Cash Profit Each \$6 Sale. No cold calls necessary. We furnish prospects. Choice territories open. Sales kit FREE. Write C. I. Link, Pres., 638 Central Savings Bank Bldg., Denver, Colo.**

**BIG MONEY** applying gold initials on automobiles. It's the easiest thing today. You make \$1.45 profit on every \$1.50 job. No experience needed. Free samples. RALCO, MY-1088 Washington, Boston, Mass.

**TEA AND COFFEE ROUTES OPEN. PAY UP TO \$42.50 A WEEK. I FURNISH EVERYTHING YOU NEED. NO CAPITAL REQUIRED. WRITE ALBERT MILLS, 9005 MONMOUTH, CINCINNATI, OHIO.**

**SALESMEN—Acquainted with auto dealers, garages, filling stations, industrial concerns, truck and fleet owners. Big Profits. Leads furnished. Territory now available. Attractive set-up for Salesmen and district managers. Write Colgra, 2652 N. Third St., Milwaukee, Wis.**

**78¢ PROFIT ON A \$1.00 SALE. IMP RINGS REDUCE COST OF COOKING BY GAS 25 TO 50%. MONEY BACK GUARANTEE. MORE THAN TWO MILLION SOLD. MARTIN WRITES "I HAVE SUPPORTED MY FAMILY FOR THE PAST YEAR SELLING IMP RINGS." SOME TERRITORY OPEN. ECONOMY APPLIANCES, DEPT. MC, 10% SOUTH CANAL STREET, CHICAGO.**

**MANUFACTURERS MIRACLE GAS WANT TERRITORY DISTRIBUTORS. USERS REPORT 33 1/3% AND MORE INCREASED MILEAGE. AUTO CLUB APPROVED. 500% PROFIT. ILLINOIS LABS, T-1244 NORTH DEARBORN, CHICAGO.**

**AMERICA'S GREATEST FOOD BARGAINS! MIRACULOUS PREMIUM DEALS! VALUES THAT BEAT CHAIN STORES. BIG PROFITS. MAIL POST-CARD TODAY. M. C. KENNEDY CO., KOKOMO, INDIANA.**

**MEN—1000 Bargains. Razor Blades, Novelties, Drug Sundries. Latest Specialties. Free Illustrated Catalog. Reliable Hygienic Products, Dept. 139, 504 S. Crawford, Chicago, Ill.**

**MAGNETIC CLEANER—Entirely new. More effective than a vacuum cleaner. Sells for \$1.75. Make from \$5.00 to \$12.00 a day. F. S. Beveridge, Pres., Stanley Home Products, Inc., Box 435-M, Westfield, Mass.**

**MAKE MORE MONEY** Taking Orders Shirts, Ties, Underwear, Dresses, Hosiery, Raincoats, Coveralls, Pants, Uniforms. OUTFIT FREE! NIMROD COMPANY, Department 55, 4922-28 Lincoln Avenue, Chicago.

### ASTROLOGY

Your 1935 Astrological Reading, a daily guide in your affairs covering business matters, change, travel, vacation, speculation, bonds, stocks, love, courtship, marriage, health, accidents, days when to and when not to sell, lucky and unlucky days—a 16-page book. Send name, birthdate, and \$1.00 to Prince Eriel Kerma, Popular Radio Astrologer, K.Q.V., W.G.M., K.F.R.U. and others, 956 Madison Ave., Memphis, Tenn.

### DETECTIVES

**SPECIALIZE IN RAILROAD AND RAILWAY WORK. COURSE VERY REASONABLE. PARTICULARS FREE. WRITE INTERNATIONAL SECRET SERVICE INSTITUTE (RS-45) HOBOKEN, N. J.**

**WANTED:** Men and women to study detective profession, secret service, military and naval intelligence. Write Joseph Kavanagh, Former Agent United States Secret Service, MC-85, Hoboken, N. J.

### MANUSCRIPTS WANTED

**THOUSANDS OF DOLLARS** being paid for stories, poems, plays, songs. Free Copyright in your own name. Free submission to publishers. Submit Mss. to Mark Twain Writers', Dept. A, Springfield, Ill.

### PATENTS AND INVENTIONS

**INVENTIONS COMMERCIALIZED.** Patented or unpatented. Send sketch and description or model, or write for information. In business 30 years. Complete facilities. Adam Fisher Company, 249 Enright, St. Louis, Mo.

### CORRESPONDENCE COURSES

**USED CORRESPONDENCE COURSES** and books sold or rented. Inexpensive. Money back agreement. Write for free catalog 4,000 bargains. (Courses bought.) Lee Mountain, Dept. M-14, Pisgah, Ala.

### INSTRUCTION

**GOVERNMENT JOBS.** Start \$105-\$175 month. Men—women, 18-50. Qualify now for coming examinations. Experience unnecessary. Full particulars—list positions, FREE. Write today. FRANKLIN INSTITUTE, Dept. P1, Rochester, N. Y.

### MODELMAKING

**THE MODELMAKER.** The magazine for those interested in building model railroads, boats, engines. Send 15 cents for copy. Modelmaker Corp., 98R East Main Street, Bay Shore, N. Y.

### OLD GOLD AND DIAMONDS

**WANTED—OLD GOLD, DIAMONDS**  
MAIL us your old gold teeth—old or broken jewelry—antiques—watches—diamonds—silver. Cash by return mail. Goods returned in 10 days if you're not satisfied.  
OHIO SMELTING CO., INC.,  
815-A Hippodrome Bldg., Cleveland, Ohio.

### OLD COINS WANTED

**SELL US YOUR OLD COINS:** Up to \$53 Paid for Indian head pennies. To \$2 for Lincoln pennies. Certain nickels \$100. Other coins to \$2500. Send 10c for complete buying catalog. Coin Collectors Club, CF-700 E. 63rd, Chicago.

In answering advertisements it is desirable that you mention RAILROAD STORIES.



# Writers are made ... NOT BORN

**U**NDER competent and sympathetic guidance, thousands of people of no more than average native ability have been developed into successful writers. How do you know you don't possess hidden talent? Has it ever occurred to you that you might derive genuine pleasure and considerable profit from writing for publication?

We don't promise that overnight you'll turn out the Great American Novel or be able to command fabulous prices for your work. But don't overlook the fact that there are hundreds of editors who are paying \$25, \$50 and \$100 or more for material that takes little time to write—not fiction, necessarily, but articles on home or business management, sports, travels, recipes, etc.—things that can be easily and naturally written in spare time.

*How do you know you can't write? Have you ever tried? One thing is certain—you'll never find out until you try. For the one and only way to learn to write is by—WRITING!*

## You Owe It to Yourself to LEARN if You CAN Write!

It's not just the "big name" writers who make money. Here is a typical example of the letters that come to us constantly:



"I am able to live on the money I earn by writing, and it is not yet ten months since I began the course. Until a few months after beginning study with you I had never had a line published. What more can I say for a course which has enabled me to earn a livelihood by the most congenial work I have ever done?" John N. Ottum, Jr., Box 95, Lisbon, N. D.

The Newspaper Institute of America offers an intimate course in practical writing—a course as free from academic "isms" and "ologies" as a newspaper office—a course as modern as the latest edition of this morning's paper.

Week by week you receive actual assignments—just as if you were right at work on a great metropolitan daily. Your writing is individually corrected and constructively criticized. A group of men, whose combined newspaper experience totals more than 200 years, are responsible for this instruction. Under such sympathetic guidance, you will find that (instead of vainly trying to copy some one else's writing tricks) you are rapidly developing your own distinctive, self-flavored style. You are learning to write by writing—acquiring the same experience to which nearly all well-known writers of short-stories, novels, magazine articles, etc., attribute their success.

The time required is less than one year, the cost not more than a month's living expenses at a resident college.

### A Chance to Test Yourself

We have prepared a unique Writing Aptitude Test. This tells you whether you possess the fundamental qualities necessary to successful writing—acute observation, dramatic instinct, creative imagination, etc. You'll enjoy this test. The coupon will bring it, without obligation. Newspaper Institute of America, 1776 Broadway, New York.

**NEWSPAPER INSTITUTE OF AMERICA** 99D555  
1776 Broadway, New York City, N. Y.

Send me, without cost or obligation, your Writing Aptitude Test, and further information about writing for profit.

Mr. }  
Mrs. } .....  
Miss } .....  
Address .....  
(All correspondence confidential. No salesmen will call on you.)

## New Deal on Famous MOTH KILLER

Coins Money for Agents!



**ALWAYS** noted as the miracle profit builder of selling, the famous Puro Moth Tablets' earning capacity has lately been doubled and tripled. New give-away plan that housewives can't resist sends earnings soaring sky high in all territories. Women everywhere know Puro's reputation for effectiveness—know it is **GUARANTEED** as advertised in **GOOD HOUSEKEEPING**... prefer it to anything else. Now, liberal new bargain plan makes them spend more than ever for it. Some splendid territories are now open but won't be long. (Splendid distributors' proposition, also, on request.) Write for full description and details of new plan. **FULL SIZE SAMPLE FREE** if you act at once. The PURO Co., Inc., Dept. C-304, 3107 Pine St., St. Louis, Mo.



## Pocket PROFITS HOURLY

WITH HATS AND CAPS

Sensationally new line of personality styled Hats and Caps—latest exclusive designs—superior qualities—large selection—choice of seven spring colors—three price ranges. Caps tailored to measure and rain-proofed by Secret Taylor process. Twelve luxurious fabrics in four smart styles.

**WE PAY THE POSTAGE!!**

Unique sales outfit sent free just for sending name. Fits in pocket. Designed to make quick, easy sales. Simply show and write up profitable orders. No experience needed. All customers' orders sent postpaid.

**TAYLOR HAT & CAP MFRS.**  
Dept. 23-D  
15-17 W. Sixth St., Cincinnati, O.



### FREE HAT AND CAP OFFER

You don't invest a red cent. Everything free. We **give** you hats and caps to sincere businessmen. Send head size with name right now. A penny postcard will do.

## WHAT ARE? THOUGHTS?



Where do they start? What is this mysterious power possessed only by humans? Fascinating and instructive are the facts about your inner mind, your personality, your understanding;

facts taught secretly by the Rosicrucians for centuries. Learn about it; but first write for **FREE BOOKLET** to SCRIBE N. A. J. THE ROSICRUCIANS (A. M. O. R. C.)  
SAN JOSE, CALIFORNIA

## TYPEWRITER 1/2 Price

Easy Terms  
Only 10c a Day

Save over 1/2 on all standard office models. Also portables at reduced prices.

**SEND NO MONEY**

All late models completely refinished like brand new. **FULLY GUARANTEED.** Big free catalog shows actual machines in full colors. Lowest prices. Send at once. Free course in typing included.



10-day Trial

International Typewriter Exch., Dept. 336, Chicago

## Diesel Engineering

Power Plants—Motor Trucks—Busses—Locomotives  
Ships—Tractors—Dredges—Drills—Pumps—Etc.

Training at home on all latest Diesel developments—2 and 4-stroke cycles; solid and air-injection fuel systems; low- and high-speed and heavy-duty types; Diesel-electric generating systems, etc. Includes all text material, individual instruction, employment service. Write **TODAY** for Free Bulletin. No obligation. American school, Dept. D-41, Drexel at 58th, Chicago

# I WANT MEN

for TEA AND COFFEE ROUTES

Calling on 200 Families Pays Up To **\$60.00 A WEEK**



Amazing, new and sensational Gift Coupon plan provides immediate cash income for both men and women. These local Tea and Coffee Routes pay up to \$60.00 a week full time and up to \$9.50 a day even for spare time. No experience or training required. Everything furnished. Positive no-risk trial. New plan proving a sensation. Costs nothing to investigate. Rush name on penny post-card right now before your neighborhood route is snapped up by someone else. **ACT TODAY.**

**ALBERT MILLS, Route Mgr., 7501 Monmouth Ave., Cincinnati, Ohio**



## TRAVEL for "UNCLE SAM"

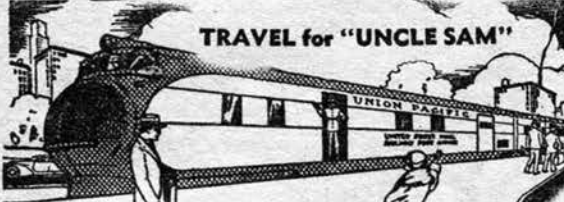

**START \$158.00 Month** Railway Postal Clerks

Many Spring government examinations expected

**FRANKLIN INSTITUTE**  
Dept. N-274, Rochester, N. Y.  
Sirs: Rush without charge, (1) 32-page book describing U. S. Government jobs. (2) Send list of Government jobs.

Men-Women Name \_\_\_\_\_  
18 to 50 Address \_\_\_\_\_

**COUPON**

# So Very Easy



POPULARITY! Step right into it with a P-A Sax. Play beautiful tunes first week. No failures. Learn quickly. Join a dance band in 90 days. Only P-A assures such rapid progress. Easiest blowing, fingering, most beautiful tone. See your P-A Dealer, or write direct for beautiful literature. No obligation. Easy terms. You can do it. Write today. 1172

**PAN-AMERICAN**  
456 P-A Bldg. Elkhart, Indiana

*Moderate Price*

## A Short Cut to BIG PAY in RADIO

New Offer

MAKES SUCCESS EASY!

SEND NOW FOR FACTS

10 Weeks Training in the Great Coyne Shops will qualify you for a better job with more pay and a real future in Radio — Broadcasting, Television, Talking Pictures, Aviation Radio. Learn by actual work on real equipment—not by books or useless theory.

**ILL FINANCE YOUR TRAINING**

My amazing "Pay-After-Graduation" plan enables you to get your training NOW... then pay me AFTER regular training period, in small monthly payments extended over a year. Free Employment Service to graduates... many earn while learning. Mail coupon today!

**H.C. LEWIS, PRES., COYNE RADIO SCHOOL**  
508 S. Paulina St., Dept. 35-1A, Chicago, Ill.

Send your Big Free Book on Radio and Coyne Shop Training, and full details of your "Pay-After-Graduation" Offer.

Name \_\_\_\_\_  
Address \_\_\_\_\_  
City \_\_\_\_\_ State \_\_\_\_\_

# JIMMIE DALE

*Comes Back in a Brand New Story*

## "The Missing Hour"

Latest Serial by

# FRANK L. PACKARD

# DETECTIVE FICTION WEEKLY

Formerly Flynn's

March 16 issue (On sale March 6)

10c Selected by the Crime Jury 10c

On Sale At All Newsstands

IF YOU DON'T WANT

**H A I R**  
DON'T USE

**LAURA'S RAPID HAIR FORMULA**

Eliminates itching and dandruff. Stops falling hair. Write for free circular. Special test treatment jar for \$1.25 postpaid. Laura Phillips, 4532 Murdock Ave., Dept. 8, N. Y. City

"POPULAR FOR GENERATIONS"

**PLANTEN'S OR BLACK**  
**C & C CAPSULES**  
**REMEDY FOR MEN**

AT DRUGGISTS OR TRIAL BOX BY MAIL 50¢  
From Planter, 93 Henry St., Brooklyn, N. Y.  
▲ BEWARE OF IMITATIONS ▲



**High School**  
**Course in**  
**2 Years**

You can complete your High School education at home—in 2 years or less. Course meets all requirements for entrance to college and leading professions. Standard H. S. texts supplied. Diploma awarded. Full credit for H. S. subjects already completed. Send for Free Bulletin TODAY. No obligation.

American School, Dept. H-436, Drexel at 58th, Chicago

**We Buy PENNIES**

Send 10¢ for Coin Catalog and receive FREE, latest Buying List for used and unused Stamps.

Will pay up to \$53 for certain Indian head pennies. Up to \$2 for certain Lincoln heads. Up to \$100 for nickels. Other rare coins up to \$2500. Save all old money. Also stamps. May be worth a fortune. Send dime (coin) for complete, large size Buying Catalog.  
**COIN COLLECTORS CLUB**  
700 E. 63rd, Dept. CF-2, Chicago, Ill.

**WALDE'S WONDER SALVE**

RESULTS ARE REMARKABLE!

It is more than a first aid, everyone should have it. Sold with a money back guarantee. For—Infections, Boils, Burns, Old Sores, Fresh Cuts, Bruises, Sprains, Ulcers, Felons and Sore Eyes.

**TRULY A WONDER PRODUCT**

Order Now. 50¢ Prepaid

H. R. WALDE, Lake Wales, Fla., Dept. D.



DO YOU WANT TO

**STOP TOBACCO?**

Banish the craving for tobacco as thousands have. Make yourself free and happy with Tobacco Redeemer. Not a substitute, not habit forming. Write for free booklet telling of injurious effect of tobacco and dependable, easy way to relieve the craving many men have.

**FREE BOOK**

NewellPharmaceutical Co.  
Dept. 315, St. Louis, Mo.

**Kidneys Cause Much Trouble Says Doctor**

Successful Prescription Helps Remove Acids—  
Works Fast.

Dr. T. J. Rastelli, famous English scientist, Doctor of Medicine and Surgeon, says: "You can't feel well if your Kidneys do not function right, because your Kidneys affect your entire body."

Your blood circulates 4 times a minute through 9 million tiny, delicate tubes in your Kidneys which are endangered by drastic, irritating drugs, modern foods and drinks, worry, and exposure. Beware of Kidney dysfunction if you suffer from Night Rising, Leg Pains, Nervousness, Dizziness, Circles Under Eyes, Acidity, or Loss of Pep.

Dr. Walter R. George, for many years Health Director of Indianapolis, says: "Insufficient Kidney excretions are the cause of much needless suffering with Aching Back, Frequent Night Rising, Itching, Smarting, Burning, Painful Joints, Rheumatic Pains, Headaches, and a generally run-down body. I am of the opinion that the prescription Cystex corrects such functional conditions. It aids in flushing poisons from the urinary tract, and in freeing the blood of retained toxins. Cystex deserves the indorsement of all doctors." If you suffer from Kidney and Bladder dysfunction, delay endangers your vitality, and you should not lose a single minute in starting to take the doctor's special prescription called Cystex (pronounced Siss-tex) which helps Kidney functions in a few hours. It is swift, safe, and sure in action. Gently tones, soothes, and cleans raw, sore membranes. Brings new energy and vitality in 48 hours. It is helping millions of sufferers and is guaranteed to fix you up and make you feel like new in 8 days, or money back on return of empty package. Get guaranteed Cystex from your druggist today.



Dr. W. R. George

Cystex (pronounced Siss-tex) which helps Kidney functions in a few hours. It is swift, safe, and sure in action. Gently tones, soothes, and cleans raw, sore membranes. Brings new energy and vitality in 48 hours. It is helping millions of sufferers and is guaranteed to fix you up and make you feel like new in 8 days, or money back on return of empty package. Get guaranteed Cystex from your druggist today.

**MAGIC CASE**

**Delivers LIGHTED Cigarettes**

I TOUCH A MAGIC BUTTON!

A NEW WAY TO SMOKE

Look! I pull out this beautiful enameled case! I touch this magic button! There is a spark... a flame! A LIGHTED Cigarette appears! I put it to my lips. I puff! The cigarette slides easily from the case without a touch of my fingers... comfortably between my lips. I SMOKE!

AT THE TOUCH OF A MAGIC BUTTON

I PUFF AND SMOKE!

15-DAY TRIAL OFFER

Say the word and we'll send you a Magic Case on 15 days' trial at our risk. And facts that fairly scream big profits. Men are wild to buy the minute they see the Magic Case. Priced so low anybody can afford it. We'll tell you how you can hand out dozens, Hundreds, THOUSANDS... and cash in up to \$75 to \$100 a week. Write today.

MAGIC CASE MFRS., 4234 Cozens Ave., Dept. C-429, St. Louis, Mo.

**BE A RAILWAY TRAFFIC INSPECTOR**

A FIELD WHERE PAY ADVANCES ARE RAPID TRAINED MEN—19 to 50—wanted as Railway and Bus Passenger Traffic Inspectors. Healthful, fascinating work; travel or stay near home. Complete our few weeks' home-study course and we will place you at up to \$140 per month, plus expenses, to start, or refund tuition. Experience brings rapid advancement. Help yourself to a real career. Write STANDARD BUSINESS TRAINING INSTITUTE, Div. 5004, Buffalo, N. Y.

**PILES DON'T BE CUT**  
Until You Try This Wonderful Treatment

for pile suffering. If you have piles in any form write for a FREE sample of Page's Pile Tablets and you will bless the day that you read this. Write today. E. R. Page Co., 2231-V Page Bldg., Marshall, Mich.

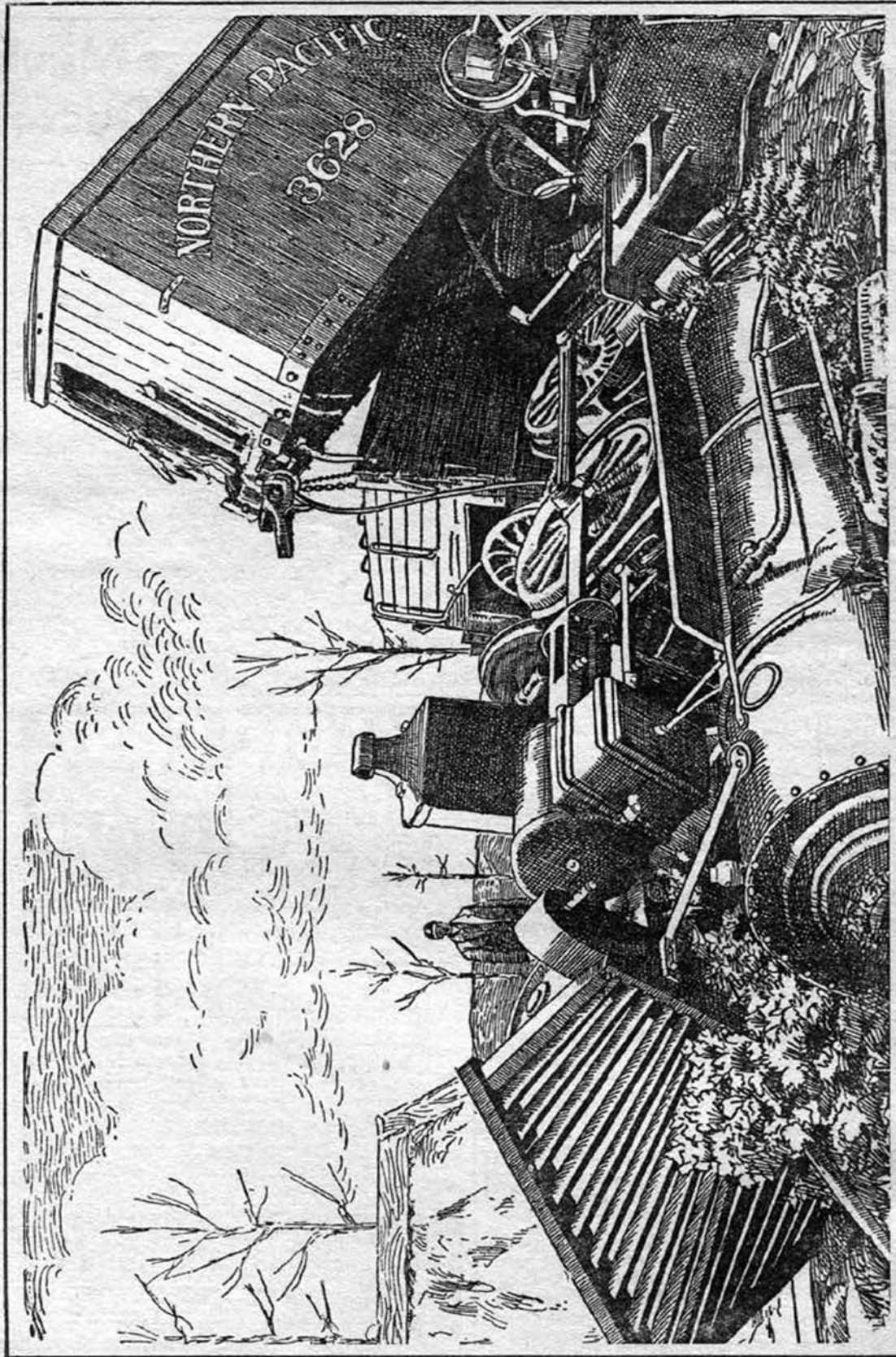

"This Wreck, Which Happened on a Northwestern Road," Said an Old Account, "Is One of Those Sad Incidents of Railroad Operation That Render the Life of a Railroad Man So Much Like That of a Soldier in Actual Service." But Don't Guess Too Soon; the Northern Pacific Box Car Was Away from Home. Where the Wreck Actually Happened the Old Account Did Not Say. Does Any Reader Know?"



# Blanket Stiffs

*An Old Tramp's Life Story Is Told in Five Words: Lilacs, Lightning Bugs and Lavinia*

By DAVE A. MARTIN

Author of "The Greatest Engineer In the World" and "Beginner's Luck"

**Z**OWIE! Me and the Kokomo Kid's getting up in society. Oldest living charter members of the Ancient Order of Blanket Stiffs. The real blanket stiff, as everybody knows, is a 365-days-a-year tramp. He totes a bed blanket and uses it wherever night finds him.

Our main problems is rassling with the three R's—resting, rambling and relaxing. Right now we're riding local freight in Missouri. We heard the brakies on the Mop ain't so hostile as on other roads, so we shuffle up to a scissor-bill and asks him about it.

"Nothing doin'," he bellows. "If I see you 'boes climbin' into that empty box car up ahead I'll knock your blocks off." While we're scrambling for the side-door Pullman he mentioned, he shouts after us the bad news: "Don't forget to pile out at Henrietta an' juggle some uh that freight."

Them shacks gimme a pain. Never think of nothing but work—for somebody else. You just watch. I bet me

and the Kid fixes him in due time.

When we crawl into that car there's about twenty 'leven fuzzy-faced boys in there already. We ask where they're going. Most of 'em says they're heading for hell.

That's just about true. Thousands of boys with ambition but no jobs are flipping freight trains today for the thrill. Tomorrow, thousands of boys with no ambition and no jobs will be riding the rattlers as a lifetime habit. Shiftlessness gets under the skin and sticks. I know. Look at me and the Kokomo Kid. Just plain unadulterated bums.

"Last real job and pay check I had," says the Kid, "was over forty years ago."

"That's a long layoff," I sigh.

"Yes," he goes on, "in '94, the year of the Pullman strike, I was a telegrapher on the old Monon. And then the only girl I ever had in my life pulled the pin. I hit the derail and landed, wheels up, in a ditch."

That set me to thinking that when

you yank the props out from under ambition it's only a step from the sidewalk to the gutter.

"Kid," says I, "ever since the days of Eve in the Garden uh Eden, them rags an' bones an' hanks uh hair has been turning switches an' throwing us fellers onter dead-end sidings to rot an' rust—an' it's just too bad!"

"Oh, not so bad," the Kid grins. "I sorta like this life. Yesterday Boston, today Chi, tomorrow maybe Vancouver or San Diego. Pick out your own weather."

"Yeh," I says, "an' why worry if it's a week from last Tuesday or the thirty-ninth of February?"

We was getting philosophical. We do once in a while. The Kid says:

"Hit the farmhouses in daytime for a big feed, and the haystacks at night for a big snooze under the stars. Your alarm clock at daybreak is a field full of songbirds. Get up and dress on a knee-deep rug of wild flowers. Jam on your hat and you're dolled up for the day."

"Yeh, it ain't so bad," I agree. "Nothing to do but sprawl out an' rest an' neighbor with Nature. No landlord, no taxes, no budget, no breach uh promise suits—" That reminds me of the Kid's gal, and I change the subject. "Did your dame quit 'cause you hit the skids?"

"No, it's the other way round," my pal says gloomily. "I hops off the rails onto the ties 'cause she pulls her freight on me."

I nod sympathetically but don't say a word.

"Some men are like engines," he says. "They run outa sand, flues leaking, no steam, schedule all shot. Back shop for a rebuild or the junk heap. That's where I lit, on the scrap pile."

We got lots a time and nothing special to do, so he unravels a story.

"LAVINIA'S her name. Sorrel top Land freckle face. No blue-ribbon beauty, but suits me to a T. On spring-time evenings, after my day's trick pounding brass for the Monon, I stroll out to her home. Picture twilight in a country town. Sweet honeysuckle trailing over the house. Yard full of lilac bloom—her favorite flower.

"We sit on the porch in love's young dream, while the fireflies hang their lanterns among the lilacs. A night hawk whirs overhead. A bullfrog orchestra in a cat-tail marsh lulls the last vestige of day life to rest. Happy hours.

"That's over forty years ago, but I always think of those three like yesterday—*Lilacs, lightning bugs and Lavinia*. An old tramp's blessed trinity."

He paused reminiscently.

"Speaking of forty years ago and breezing along in a box car," the Kid goes on, "reminds me of rolling into Sierra Blanca one morning about sun-up cold, tired and hungry. Sierra Blanca is just a depot in the West Texas desert. Sand, sagebrush, stunted, wind-swept mesquite reaching out everyway to the sky line. Me and two old-timers get ditched there.

"But, 'bo, that depot at Sierra Blanca is manna in the wilderness. It's a real railroad eating-house. All trains of two rail systems stop there for meals.

"Our freight's just settled on the siding when a long passenger train grinds to a stop at the platform. A Chink in the depot door is beating a big brass gong. Train passengers in linen dusters are unloading for breakfast.

"The two old-time tramps who was

"Say, Mister, We Don't Like That Word  
'Work.' We Ain't Done a Tap o' Work for  
Twenty Years"

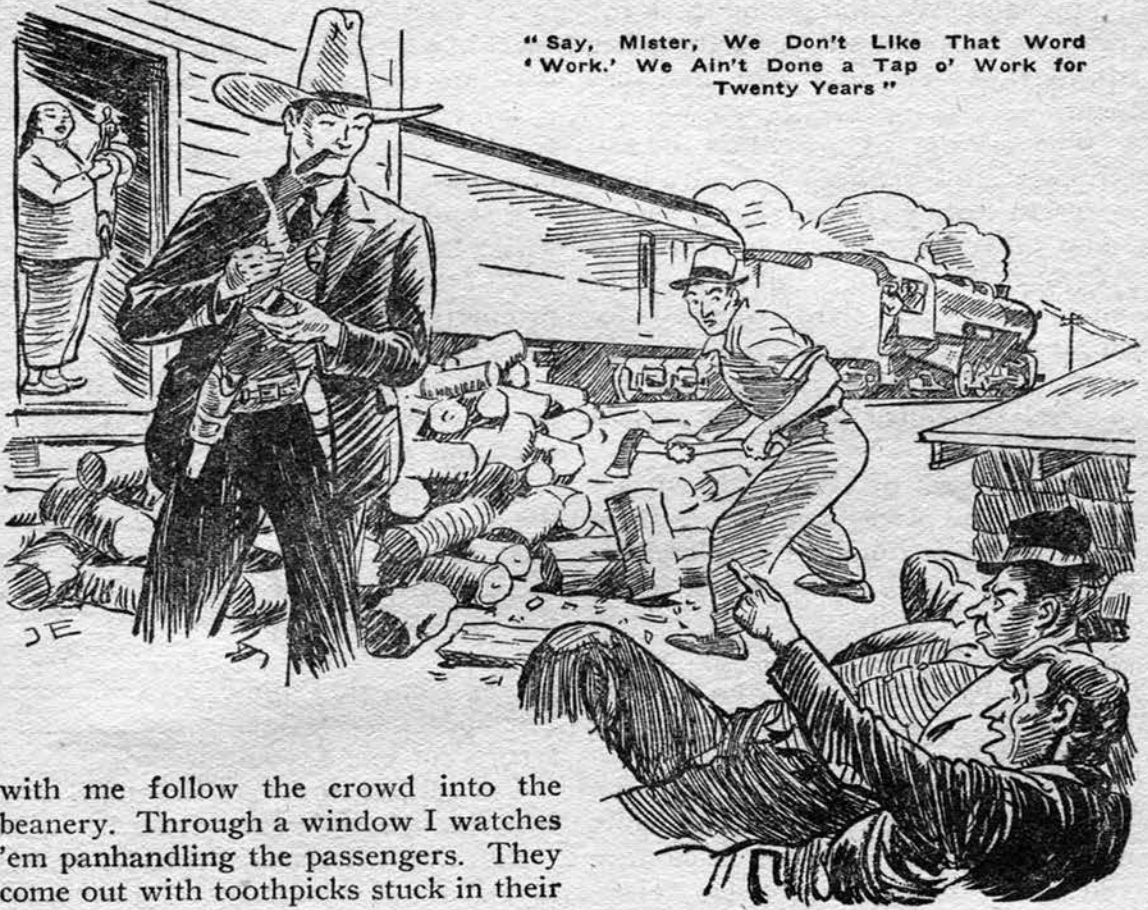

with me follow the crowd into the beanery. Through a window I watches 'em panhandling the passengers. They come out with toothpicks stuck in their faces.

"'Did you feed?' I inquire.

"'Did we feed?' they says. 'Kid, if we tip our heads we spill it.'

"Me, I'm just a greenhorn then at frisking the world for a living. When the rush is over I'm back in the kitchen interviewing the Chink chef.

"'You hunglee?' he wants to know. 'You likee work? Chopee wood?'

"Soon I'm making little ones out of big ones at the wood pile. The two old-timers are sprawled out close by for a session of shut-eye.

"Out of the depot walks a raw-boned, square-jawed hombre under a church-steeple sombrero. Port and starboard, he's toting for ballast a Colt's forty-five and the grand-daddy of all bowie knives. Stuck in his cow-

hair vest I discover a badge that reads 'U. S. Deputy Marshal.'

"The big boy barges alongside the two tramps and gives 'em the lowdown on the free lunch situation in Sierra Blanca. He talks soft and easy, like a rattler when he's warning.

"'You fellers can work for your grub if you want to,' says he, 'but don't pester any more passengers here—savvy?'

"One of the tramps half up-ends and spits back: 'Say, mister, mebbly you're runnin' this eatin' shebang but you ain't runnin' us, see? An' we don't like that word *work*. We ain't done a tap o' work for twenty years.'

"The second bum chips in after his pal. 'Yes, an' twenty years is only

half the tale. We ain't gonna work for twenty years more, an' that's the other half of it. Now, how d'ye like that story?"

"The Big Boy's got sand on the rail and never slips a wheel. 'I ain't long on writin' myself,' he says, 'but I reckon I'll scribble a little postscript to that story. You two hombres are both gonna work—an' hard work—befo' you git outa here. When you're ready for some physical exercise, look me up. An' remember about the passengers.'

"A full week of choring is what I get out of the place—everything from whitewashing hen-houses to chamber-maiding for nanny goats. First job is to pick out all the crooked, knotty, tough-to-split sticks from a big wood-pile. This made-to-order heap was for the two birds who'd been resting up for twenty years.

"Day by day I'm getting the wrinkles out of my filling station while the two old-timers are on a hunger strike. The marshal's got 'em sewed up tight in Sierra Blanca. No place to eat but the depot. Crews bat and boot these two bums off the trains. *Walking* out would mean bait for the buzzards.

"On the fifth day the ragged pair limp into the depot looking for the marshal and work. They're sore, starved and licked. At the end of the week I get a five-spot and am fixed for a ride to El Paso. Last thing I see from the caboose cupola, as we slide down the track from Sierra Blanca, is those two tramps still making wild ax swings at hump-backed sticks of wood."

**O**UR rattler slows down and jerks to a stop. The car door slides back. The tough brakeman shouts in:

"C'mon, c'mon, c'mon! Roll outa there! You 'boes hit the grit! Hustle back an' tangle with that freight!"

Everybody unloads except me and the Kokomo Kid. We got the car to ourselves.

I slip the Kid a grin. "You don't s'pose he meant us too, do you?"

"Certainly not," the Kid says promptly. "You heard him say 'boes. We're blanket stiff."

That settles it. Kokomo's judgment on labor questions is fine. We edge over and shut the door.

When we're rolling again I says to the Kid: "Not a bad yarn, that last one. I can't figure out, though, why this Lavinia romance of yours jumped the track an' landed in a ditch."

"No?" counters the Kid. "Well, maybe you ain't good at arithmetic. But speaking of figures reminds me: I sure cut one a while back."

I'm all set for another story, and sure enough, it comes along.

"I'm on a branch railroad up in Alberta," the Kid narrates. "Been fired off a Canadian Pacific freight. I'm drilling down the track, eyes on the fields, looking for a scarecrow to swap clothes with. Never so near ready for a nudist colony in all my life.

"Right in the middle of the track, at a road crossing, I find a suit box. It has jiggled out of some wagon. In it is a swell new outfit of sartorial habiliments—the whole layout from shoes to Stetson. I cache this trousseau in a thicket of underbrush so's they'll be safe and the owner can find 'em easy.

"A week later when I slip back, what do you think I find? The fellow who lost them clothes didn't want 'em bad enough to come after 'em. Did they fit and look ritzy! Say, all I was short of being a sheik was thirty years of



life, a shave and some hair slicker.

"A few miles down the line a kind-hearted lady gives me a big handout wrapped in a newspaper. I always like to read the news at lunch—especially the financial news. One item in that paper was so interesting I saved it."

The Kid fishes out a grimy tattered newspaper clipping which he reads:

#### SURPRISING MRS. SKINNER.

There has been dirty work at the crossroads or somewhere between town and the Plum Creek ford. Ab Skinner, our esteemed fellow citizen of the Plum Creek district, is out one complete change of brand new, high class, spic-and-span's Sunday-go-to-meeting wearing apparel. And some miserable, unprincipled, thieving, low-down human polecat is now probably wearing the same.

Lafe Cowdrey, our town marshal, is hot on the trail of the miscreant. An important arrest is expected at any time. To date Lafe has ferreted out some mysterious facts in the case as follows:

Ab came to town last Thursday with a wagon load of spuds. According to Ab, his wife had been "riding" him for five years to get some decent duds. As Ab tells it, when he did cut loose he loaded up with everything in men's nifties from neck yoke to tail gate, not because he wanted or needed them, but to pacify Ma Skinner. This box of new regalia was tossed in the wagon for the trip home.

Mid-stream at the Plum Creek ford a bright idea struck Ab. He decided to tog up in his new outfit and surprise Ma Skinner when he gets home. While the team was drinking, Ab stood up on the wagon seat and shucked the old duds. He sang out:

"Good-by, old overall! Good-by, old jumper! Good-by, old hat."

He wadded each item up, threw it as far as he could, and watched it disappear down stream. When there was nothing else left to discard but a pair of polka dot scanties and one set of chin whiskers, Ab reached for the new outfit—but the box was gone!

It was two miles from the Plum Creek ford to the Skinner farm, and the frost was on the pumpkin last Thursday. Ab is ready to bet either potatoes

or money he holds the two-hoss wagon record for that distance.

The Ladies Aid Society of Emanuel Baptist Church met at Mrs. Skinner's last Thursday. This has gone as far as the porch in the breaking-up stage when Ab flashed past the house, minus the wagon seat, and disappeared behind the barn like a standing Roman charioteer in his peek-a-boo costume.

Not only was Mrs. Skinner surprised at Ab, but every good sister in the Ladies Aid Society had the shock of her life. . . .

"Believe me, pal," says the Kokomo Kid, "I make tall tracks out of that neck of the woods. Instead of picking my freights, I'm grabbing them as they come. What I'm looking for is distance. How could I plead 'not guilty', with the evidence covering me like a show bill on the side of a barn? But I had good luck. Got caught in a rain-storm. That suit was ninety per cent cotton. When the sun got through working on it I looked like little Lord Fauntleroy with whiskers. It was a dandy disguise all right."

OUR train has bumped to another stop. The door is jerked back. Our tough brakie glares in.

"Hey!" he barks. "What's the matter with you bums? Didn't I tell you to unload an' grapple that freight at Henrietta?"

"You sure did," the Kid says cheerfully, "but we ain't heard you call 'Henrietta' yet."

The brakie blows up. "Ain't *what*? Say, do you guys by any chance think you're riding the Sunflower Limited? Now, when we git down to Sibley you two hit the deck an' tie into an armload of boxes. Git me?"

"Got you," says the Kid.

The door cracks shut and we're off again. I says to the Kid:

"That yarn about Ab is O.K. But about you an' Lavinia, I can't under-

stand why two young people hit the derail when there's life ahead of 'em, a clear track to happiness, an' steam to get some place in the world."

"Don't shed your shirt," the Kid replies. "We'll get around to that later. But first I'd like to tell you about the time I got caught in a blizzard in Montana."

Time is hanging heavy on our hands, so I says: "O.K. Shoot the works."

The Kid begins: "I ride into a little town, straggling down a mountain gulch, on the hurricane deck of a freight. Mercury doing a Steve Brodie to the bottom of the bulb. Night is chasing the last streaks of daylight over the jagged, western horizon. Jack Frost is whistling out of the North. A few snowflakes are falling. I drop off the train and scoot for cover. Surest shelter is the town jail. I make a bee line double quick for that.

"The jailhouse door is opened by one of them kind, motherly, old-fashioned souls like you see pictures of on maple syrup cans. I tell her my troubles. Away she patters to get 'Pa.' Pa comes in and gives me the optical once-over. He steps up close and runs practiced hands over my rags. The badge on his vest is level with my eyes. He's a big walloper.

"'Y'ain't packin' a gun, are ye?' he asks cautiously.

"'Excuse me, sheriff,' says I, 'you got me wrong. Hobo it is, not highwayman.'

"'Yes', says he, 'I know what you look like, but right now we gotta be extry careful an' play safe. However, we ain't aimin' to turn you out in this weather.'

"Ma is already buzzing about setting out my supper. As I stow the grub away I'm watching both of 'em out of the tail of my eye. Ma keeps

sniffing and wiping her eyes on her apron. Pa is walking the floor nervously and throwing glances at a telephone on the wall like he's expecting something. I says to myself: 'Don't know what it is but a cog's slipped around here.'

"After the feed I'm taken out in the jail and locked up for the night. There's a dozen cells—six on a side facing a center aisle. Only light in the jail is one bulb at the far end of this aisle. A man on a chair is sitting, still as a statue, under this lamp. He don't even look up. Sheriff says nothing and I say less, but I'm thinking: 'Maybe he's wax works or wooden ware.'

"In my cell I can see nothing but the outline of a cot in the outdoor gloom filtering in through a small barred window. Snow is coming down heavy now. Already it's a white world outside. The only sound that breaks the silence is the cheerful tick of an alarm clock somewhere.

"The jail is warm as a pup's nest. The bed is good. And I'm at least one shift short on shut-eye. As I drop off to dreamland I keep thinking: 'This calaboose is cuckoo, but it's O.K. at that.'

"The pound of moving feet wakes me up. I lie still and listen. In one direction it's the milling of many feet and the muffled hum of voices. In another I can pick out the measured stride of one person on a cement floor; can even count the paces—three and a turn—three and a turn. Sounds like someone walking a cell.

"Time? I don't know. My watch has stopped—at the hock shop five years ago. But I can still catch the chipper little chatter of the alarm clock. I slide off the bed and peer through the window. The first glimmer of new

day is peeping over the rim of a frozen earth. What I see is a picture of dreary desolation. The snow has stopped falling, but a vicious howling wind is swirling a smother of powdery flakes through the air straight from the Arctic. That's one time at least, I'm glad to be on the inside looking out."

**T**HE Kokomo Kid is telling his story, to the tune of box car wheels clicking over Missouri Pacific rail joints; and I'm all ears, as the corn says. I'm waiting to hear how Lavinia busted a romance.

"A shadow flits past my cell door," the Kid goes on. "Pressing close to the bars I watch it vanish down the aisle. It's the sheriff. That's all I see—just one glimpse of the law passing from the shadows before me into that slab of light at the end of the corridor. All the rest I hear, and that's plenty.

"The pacing feet stop. A lock clicks. A dry hinge complains on an opening cell door. Not a sound then for seconds but the tick of the clock. Finally, the voice of the sheriff, husky and shaky:

"'Did you rest good, Billy?'

"The voice that answers is firm. It even sounds cheerful. 'Like a baby, sheriff. Whatever I'm behind I'll catch up on soon, anyhow.'

"'What'll you have for breakfast?' the sheriff wants to know.

"'Nothing this morning, thank you.'

"Another brief silence that the sheriff breaks: 'Ma and me ain't slept a wink the livelong night. Been settin' right up ag'inst that telephone every minute watchin'—an' hopin'—an' prayin' for word from the Governor. Ma's out there yet still hangin' onto her faith in Divine Providence an' belief in some last-minute message. But the time's gittin' mighty short now.'

"'I know it, sheriff, and I'm ready.'

"Me, I'm beginning to get a ghastly suspicion in my mind. I hear the rustle of a paper, the clearing of a throat, then the quavery voice of the sheriff:

"'I—I gotta read you the—the death warrant, Billy.'

"Weak and limp I sag against the cell bars. Jumping Jehosophat! I'd dropped off in the town for a night's lodging and landed right on top of a necktie party! This bozo is going to stretch hemp, and the guy I'd seen sitting in the aisle was the death watch.

"The condemned prisoner is kicking on the last legal formality. 'If it's all the same to you, sheriff, I prefer you didn't read it.'

"'But I got to. It's the law.'

"'All right; go ahead. But you was in court, same as I was, and heard the judge say that on this day at sunrise you were to hang me by the neck until I was dead. Well, this is the day and here we are—waiting for the sunrise.'

"After a pause the sheriff says: 'Parson's outside. Don't you want to see him a minute, Billy?'

"'No, I guess not. If I haven't got it squared with the Almighty for my place in the Hereafter, no one else can fix it for me.'

"'Mebbe you're right. I hope you are.' Anybody could spot the sorrow in the sheriff's words. 'You ain't bad, Billy. You've just made a mistake. We all make 'em. That's life.'

"Another awkward pause. Then the officer says: 'I'm asking you once more, for the last time, won't you tell me your right name?'

"It's almost dawn now. Along the eastern horizon I can see all the changing colors of the coming sunrise. For a few seconds I hear nothing but the tick of the clock, measuring off the final minutes of a human life. The

doomed man finally shatters the silence.

"'I can't tell you for publication, sheriff,' he says. 'It would break my old mother's heart. But will you do me a last favor?'"

"'Yes, if it's in my power.'"

"'Thanks,' the prisoner says calmly. I can't see the guy, but from the way he talks I imagine there's a look of infinite peace on his face. 'Under my bunk is a package. Please open this after I'm gone. In it you'll find two hundred postcards all filled out with lies about what I'm doing, how fine I'm feeling—you know, little splotches of cheerful sunshine. They're all addressed to my mother. Send one to her every month. She'll never outlast the pile, but I want her to get them as long as she lives. I know you'll keep my secret.'"

"The first rays of the new sun creep over the rim of the storm-swept world. A beam stabs the shadow in my cell. And when I hear the sheriff it is the cry of a heart in anguish:

"'Our Father in Heaven, give us courage, give us strength. In this dark hour, in this awful place, we ask Thee to walk hand in hand with this boy into Life Eternal. . . .'"

"A moment later there comes a voice inspired. It's the prisoner singing, clear as a bell, a murderer singing like an angel: 'Jesus, lover of my soul.' And to this, the slow tramp of marching feet, like clods hitting a coffin. An iron door clangs. Then silence. A dead, ominous, significant hush. Even the clock ticks have stopped."

**T**HIS tale sorta gets under my skin, and I tell the Kokomo Kid: "Kid, you gimme the gooseflesh. That ain't a bad yarn—to have a nightmare on. But I wanta hear about you an' Lavinia."

"Oh, that one?" the Kid replies, serious as an owl. "That's my life story, pardner."

"Sure, I guessed it," says I, "an' it must be a dandy. Let's have it."

First time since I've known the Kokomo Kid, he seems stuck for words. I tell him to drop a little sand on the rails. As he hesitates I can almost see the door opening on a human heart and glimpse the romance of a lifetime hidden within. This story's bound to be a pippin, I keep telling myself. Finally, like an old lady discovering the end of her tangled yarn, the Kid finds himself.

"Every spring, in lilac time," he says kinda slow, "I beat my way back to a little, sleepy, one-horse town in Indiana. 'Round twilight, when the fireflies are coming out, and the bullfrog orchestra in the cat-tail marsh are tuning their fiddles for the evening concert, I meander down the dusty trail, through the jimson weeds to our meeting place.

"There in the gloaming we have our reunion, like old times. The stone is half hidden under the lilac bloom, but from the glow of the lightning bugs' lanterns I can read my life's story inscribed on its face: *Lavinia Shannon—Born Dec. 12th, 1874—Died Aug. 22nd, 1894.*"

**I** DON'T say a word—not for a long time. But I keep thinking of that line about fools rushing in where angels fear to tread. Looks like the Kid's run out of talk, too. First thing we know the train stops, the door slams back and our tough brakeman roars in: "Hey, you old blanket stiffs in there!"

The Kid says: "I reckon he means us now."

We shuffle over to the door, and the shack bawls: "Hit the grit! Unload! Beat it! No work, no ride."

"Coming up," says I with a big grin. "What town did you say this is, cap?"

"I ain't said yet," he flings back, "but it's Courtney."

Then the Kid cuts in: "Thanks a lot for calling us. It's just the very spot we want to get off at."

And that's exactly what we did. That brakeman ain't so smart. Bet he feels cheap when we walk off and won't ride on his old train any more. What do we care, anyhow? Be 'nother freight along tomorrow, or next week, or next summer. Any time suits us.

## Vanished Cargo



**B**ACK in the early days railroad shippers opened their crates and boxes of "merchandise" to find nothing inside but rags or old magazines. Interesting as the magazines may have been, they were not so valuable as imitation silk stockings or cartons of cigarettes. Most ingenious was the removal of an Illinois Central carload of sugar shipped from Chicago. Arriving at Denver, the car was found quite empty except for a little snow which had sifted through

a crack. No one in Denver had ordered snow. The wires were soon crackling.

"Where's the sugar?" demanded the agent at Denver.

"In the freight car," the Chicago man wired back; whereupon the Denver man scratched his head and sent for a railroad detective.

"The question is," said the bull, "when did it snow?"

It hadn't snowed at all in Denver; the fall had ceased two hours out of Chicago. Hence the sugar had been removed at or near Chicago. In the freight yard? That was most likely, though the car apparently had not been out of sight of train crews.

The detective went to Chicago and looked things over. The only place where the sugar could have been unloaded handily was at the loading platform.

"There must be some crooks working for this railroad," the bull decided. He found a hammer and tacks, which he put in his pocket, and wandered around the yard. When no one was looking, he pried up tacks and removed an "empty" card from one of the cars. Then he located a car bearing a card for Denver. He took this card off and put on the "empty" in its place. Then he copied down the car number and departed.

Some hours later the bull returned and found the "empty" had been shoved up to the loading platform. No guards were around, as there was not supposed to be anything valuable in these cars.

"This," he said, "is where the sugar was removed—into trucks." He restored the Denver card. In the morning a yard crew, surprised to find a loaded car at the platform, yanked it off to the Denver train. The detective watched for changed cards, and eventually landed most of the crooks.—Jim Holden.

## "REAL SHAVING COMFORT NEVER COST ME SO LITTLE!"

● "I never dreamed a low-priced blade could shave a tough beard like mine until I tried Probak Jr.," writes T. C. Schreiber, Jr. "Now I get clean, easy shaves with never a bit of irritation and I'm saving money on razor blades."

Get the benefit of unequalled manufacturing methods—automatic tempering, grinding, honing and stropping. Enjoy real shaving comfort at lowest possible cost. Try Probak Jr.



Probak Junior is a product of Gillette and fits all Gillette and Probak razors.

**NOW!**  
**PROBAK JUNIOR**  
**4 BLADES FOR 10¢**  
Also packages of 10 blades for 25¢ and 25 blades for 59¢ at your dealer.



View of the  
Nashville  
Wreck, Drawn  
from a Photo

# America's Greatest Rail Disaster

By E. B. HEINEMAN

**D**URING the summer of 1918 the newspapers had little space for anything except war material, and every issue was crammed with casualty lists, war dispatches, and propaganda. Those printed on July 9th and 10th were no exception. It would have taken a careful reader to discover in most of them news of what was—and still is—America's greatest railroad disaster.

It happened sixteen days after the horrible rear-end collision on the Michigan Central at Ivanhoe, Ind.,\* which was probably the world's greatest circus wreck, and the news about which was also played down, either deliberately or because it seemed unimportant just then. American railroads had

recently come under government control, and although the United States Railroad Administration was not to blame in either case, these wrecks were bound to discredit government operation in the eyes of people who did not understand.

America's greatest railroad accident, from the standpoint of casualties, occurred on the Nashville, Chattanooga & St. Louis Ry. at Nashville, Tenn., early on the morning of July 9th, 1918. It killed 99 and injured 171 people.

Ordinarily the N. C. & St. L. was one of the safest of all railroads, just as it is today. But no scheme has ever been devised, on the N. C. & St. L. or any other road, which will allow two opposing trains to run on the same track at the same time. And no rule has been figured out that permits an inferior train to run on a single track when a superior train is already there.

\* See "When the Circus Went West," in our Feb., 1935, issue.

The trains which tried this stunt were passenger trains Nos. 1 and 4. The latter was scheduled to leave Nashville at 7 A.M., whereas No. 4 was due to arrive ten minutes later. Ordinarily they met on the double track between the Nashville Station and Shops, two and a half miles out.

The double track ended at Shops. Thus, if No. 1 was somewhat late in arriving at Nashville, it was up to No. 4 to wait at Shops until No. 1 arrived. No. 1 was the superior train.

No. 1 consisted of 4-6-0 type engine No. 281, hauling one baggage car, five wooden coaches, a steel Pullman, and a steel under-frame Pullman. She was on the way from Memphis to Nashville, and she passed Bellevue, Tenn., 12.6 miles from Nashville, at 7.09 a.m., 30 minutes late.

Meanwhile, Train No. 4 had left Nashville at 7.07 a.m., seven minutes late. Before leaving, Conductor Eubank and Engineer Kennedy had received orders about a meet with another train farther out. Added to this order was a notation from Dispatcher Phillips to the effect that No. 281 was pulling Train No. 1. This was to help the enginemen and trainmen to identify No. 1.

Eubank read the order and the notation to Kennedy, and both commented on it. Kennedy's words were that "Number One was some late this morning." Both men, then, knew that they probably would have to stop and wait for No. 1 at Shops, where the double track ended. As we have pointed out, usually the two trains met between Shops and Nashville, on double track. This morning, of course, the chances were that No. 1 would be too late to get to Shops before the opposing train arrived.

No. 4 consisted of Engine No. 282, sister of the 281, a mail-baggage car, a baggage car, and six coaches, all wooden.

**W**HILE his train was on the double track Eubank was busy collecting tickets. He had showed the order with the information about No. 1 to his porter and flagman, and had told them to watch out for No. 1. Naturally, with engineer, fire-

man, porter and flagman looking for the opposing train, he felt he was safe in devoting his entire time to collecting tickets.

However, Flagman St. Clair hardly knew what it was all about. He was making his first trip as passenger flagman. Before this he had made only two trips on freight, and although Conductor Eubank handed him the orders, he didn't understand, and saw nothing in them about which to give a second thought. He later testified that Eubank had not spoken about No. 1.

While they were running between Shops and Nashville, a switch engine hauling about 10 cars in the opposite direction passed them. St. Clair saw them, but paid no attention to them. Eubank, busy collecting tickets, also caught a flash of them as they went by. He thought they were No. 1, and went back to work. It was now up to the men in the engine cab to stop and wait for the other train.

But the men in the engine cab, for some never-to-be-determined reason, did not. They kept on going, and accelerating No. 282 in her flight, raced onto the single track.

An interlocking plant was located at Shops. Operator Johnson looked out the window at 7.15 a.m. and saw No. 4 pass by, running about 25 m.p.h. Puzzled, he looked at the train sheet to see whether or not No. 1 had arrived yet. It had not.

Immediately the towerman called Dispatcher Phillips. Horror-stricken, Phillips ordered him to try to stop No. 4. The towerman sounded an emergency air whistle in a desperate effort to attract the train crew's attention. But they did not hear it, or if they did, they did not heed it.

The two trains were rushing at each other with nothing to stop them. On account of curves, a slight grade, rather dense woodland and an overhead bridge, it was impossible for the engineers to see each other's trains until it was too late. There was nothing left except to call out the wrecker and phone for ambulances.

Both trains were traveling between 50 and 60 miles an hour. They met at 7.20 A.M., on a curve two miles out of Shops,

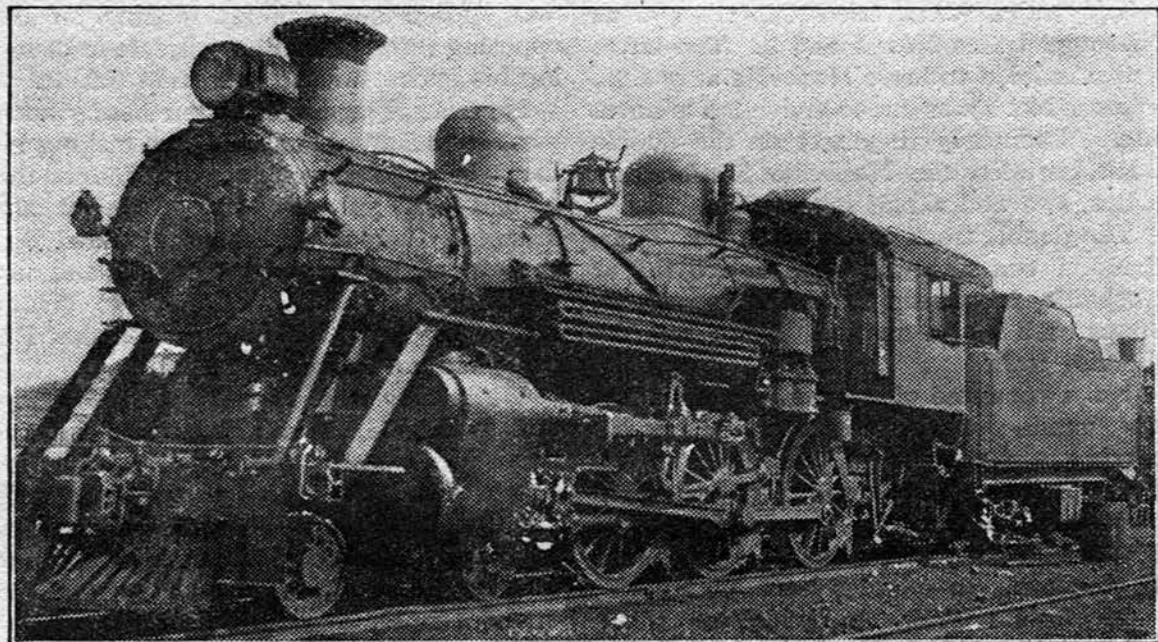

Photo by Joseph Lavelle, 4615 66th St., Woodside, L. I., N. Y.

N.C.&St.L. No. 280, Sister to the Two Engines Involved in the Nashville Wreck of July 9, 1918. She is a 4-6-0 Type, Class G8B, 22 x 26 in. Cylinders, 66 in. Drivers, Boiler Pressure 200 Lbs., Total Weight 189,900 Lbs., Built by Baldwin in 1905. Originally She Was a 4-Cylinder Balanced Compound. Rebuilt Dec. '17 at Nashville Shops

and they came upon each other so suddenly that Engineer Lloyd, of Train No. 1, did not have time to make a brake application. At any rate, that was the impression of Conductor Tucker of No. 1, who lived to tell about the crash. Kennedy barely managed to flip over his brake lever, but there wasn't time for the air to act.

No. 1's engine, the 281, was tossed off the track, her boiler stripped as clean as if she had been through a back shop. The baggage car behind her was crushed. When it was finally jacked up by the wrecking crew, thirty persons, only one of them alive, were taken from underneath. The next three cars were gouged out, shattered and tossed aside in a terrible fashion, while the last four cars remained on the rails.

As for No. 4, its engine, the 282, was also totally demolished. The next five cars were ripped and torn and tossed aside, but the last three were not derailed, and were only slightly damaged.

Who was to blame for this, America's greatest rail disaster? Obviously, you say,

Engineer Kennedy and Conductor Eubank, as well as other members of No. 4's crew. That is true, for the two men in charge of the train were primarily responsible.

But there were other factors in the wreck. While they do not lessen the responsibility of these two men, they tell why they acted as most human beings would under the circumstances.

**F**IRST of all, granted that Conductor Eubank should have made sure his train did not run onto the single track until No. 1 had passed, you must admit he *thought* he was doing so. For a long time he had been taking the word of his porter or flagman for it, and did not see anything wrong in the practice. Not only that, but Conductor Riggle, who alternated with Eubank on the run, was in the habit of doing the same thing; and although (he himself stated) he "never permitted his train to pass Shops before No. 1 arrived," he did "depend upon the flagman, porter, and engine crew to identify No. 1."



Thus the accident might have happened with any other N. C. & St. L. conductor on No. 4. It was only Eubank's bad luck that put him where he was.

Secondly, engineers on outgoing trains had been in the habit of merely taking the operator's word at Shops that superior trains had arrived. The result was that two months before the wreck the superintendent had issued the following bulletin:

Understand some engineers on out-bound trains are passing the Shops without any definite information as to whether superior trains have arrived, other than to ask operator at Shops tower. This must be discontinued.

Superior trains must either be registered before the northbound trains depart, or be identified by some member of the crew of the superior train, or meet the superior train between Nashville and the Shops, or have an order at the Shops stating that the superior train has arrived.

NOTE — See that train dispatchers understand this and have the orders ready at the Shops so they can be handed to the outbound trains.

Read it over carefully and you will see that if it had been obeyed there would have been no accident. Then why wasn't it obeyed? The answer is simple: there was no way of obeying it. The proper officials had never seen to it that orders were issued and delivered to outbound crews at Shops. The outbound trains were given no orders, so they interpreted Rule 83 (standard on all American roads) as loosely as they chose

to. Rule 83 simply states that a train "must not leave its initial station on any division, or a junction, or pass from double to single track, until it has been ascertained whether all trains due which are superior or of the same class have arrived or left." It was up to the operating officers to make provisions for the proper observation of the rule, and they did not.

In the opinion of the Interstate Commerce Commission, the accident could have been prevented if rules such as those on the bulletin had been enforced, or if there had been a manual block system on the single-track line north of Shops. It also pointed out that the loss of life would have been far less if steel equipment had been used.

Both engineers and firemen went to their death at the time of the crash. So did two other railroad men and 86 passengers. Exactly 180 were injured, but nine of them died later. A large percentage of the victims were men on their way to work in a nearby powder plant supplying world war munitions.

Thus the Nashville casualty list eclipsed even the frightful wreck of 1887 at Chatsworth, Ill. (which will be taken up in a future issue), and the catastrophe of 1876 at Ashtabula, O., described in this magazine last September. Although the famous poem about the Chatsworth wreck states that a hundred lives were lost, this figure is a poetic exaggeration. The wreck at Nashville tops the grim but now almost stationary list of America's bad railroad wrecks.

WHEN COLDS THREATEN  
... VICKS VA-TRO-NOL  
... JUST A FEW DROPS UP EACH NOSTRIL.

IF A COLD STRIKES  
... VICKS VAPORUB  
... JUST RUB ON THROAT AND CHEST.

Follow VICKS PLAN for better CONTROL OF COLDS  
(Full details in each Vicks package)

# Slippery Buck's Ballroom Run



By JAMES W. EARP

Rock Island Conductor; Author of "Summertime Snow," etc.

*Yes, Sir, It Takes a Guy Like Conductor Anderson to Show an Official How to Railroad!*



OF all the conductors I ever knew, "Slippery Buck" Anderson on the T.K.&P. is the only one to have a trainmaster tip his hat to in meeting. However, Trainmaster Fanning don't do this because he thinks Buck is the cleverest O.R.C.\* that ever bossed a train or slipped a fast one over on the officials. Not on your life! The hat tipping began after our run with the manifest freight which made history on the Siwash Di-

vision and taught local officials some of the finer points of railroading.

In the first place, it was the season for forest fires and in the second place the trainmen were going to have their annual ball at Pineville. Being the social event of the season, our whole crew planned to go. This dance is set for Friday, so on Thursday me and my partner and Buck all go down to the yard office to tell the yardmaster we want to lay off. The slave driver listens to our request.

"Nobody lays off today," he growls. "Trainmaster Fanning says the only

\* Member of the Order of Railway Conductors.

ones who can lay off are those who want to go to their own funerals or look for another job. We got four extra trains coming in the next twenty-four hours and need all the regular men we have."

"But you got lots of extra men," Buck protests. "Where are they?"

"Laying off," grins the yardmaster. "Why shouldn't they be? Their annual ball is tomorrow night."

"Some of them are fighting a brush fire over in the woods," says my partner, "Buttons" Brown. "They'll be too tired to dance very much."

Why he is called Buttons is because his clothes have so many fancy ones. He is sweet on a pretty little blonde named Mabel down at the Half Moon Café who deals grub and conversation simultaneously, and who has more suitors than a telephone girl has wrong numbers.

"But fire or no fire, I got to lay off," Buttons groans. "I promised Mabel to take her to the ball. She'd never forgive me. And if I don't take her, Sniffles will. Bet he's at the bottom of this lay-off stunt."

Sniffles Walker is a train dispatcher, the only real rival Buttons has. His nickname comes from the fact he has asthma the year around and hay fever in the fall. But for them drawbacks, Sniffles would probably have had a walkaway, as he has a better position and bigger pay check. Then, too, he is good-looking and a fancy dresser.

Personally, I'm not strong for Sniffles. He's too stuck up and ambitious. Like the other local officials and would-be officials, Sniffles don't like anybody that is a friend of Slippery Buck's. And competing with a common brakeman for a girl certainly hurts his pride.

"Looks like our work is cut out for us," Buck opines with a frown as he

squints at the line-up on the board. "We're first out. Tonight we'll catch Seventy-one, with a chance to come back on the manifest tomorrow. If we don't have too much bad luck, we'll scratch in for the dance."

"That Jonah run hasn't been in on time for months," Buttons reminds him. "It'd be just our luck not to get in at all tomorrow night."

"Well, we've got a fighting chance," says Buck. "The manifest will be on time tomorrow if I have anything to say about it. You know me, boys."

We do. He wasn't called Slippery for nothing. Me and Buttons cheer up a little as we leave the yard office and mosey on toward the beanery. There's a scent of pine smoke in the air, but the fire has been brought under control by now and we think nothing of it. As we amble along, who do we bump into there but Sniffles Walker?

Sniffles grins. "Too bad you can't attend the dance tomorrow night, Brown. It is going to be a great affair!"

Buttons comes right back at him.

"Who says I won't be there? I've got twenty dollars says I'll be there."

"Not and work for us afterward," the dispatcher drones. "Bet you on that."

"Put up or shut up!" Buttons challenges.

Sniffles claps his hands and calls him. Into the beanery they go to get Mabel to hold the stakes. Buck frowns, and says to me in a low voice:

"Buttons was foolish. Sniffles knows something, else he'd never have done any boasting or betting. Worse yet, he'll be on duty tomorrow the same hours we are. A few delays, easy for him to explain, and our cause is lost. Buttons should have let well enough alone."

WELL, Slippery Buck Anderson calls the turn. Sniffles did know something. Train No. 71 is two hours late that night and we don't get out until eight o'clock. "Lazy Lon" Bolton is our engineer. Buck hands him the orders and a little advice:

"Twist that pig's tail, Lon. Got to be in Coldwater by two o'clock so we can come back on the manifest on time. If we miss the ball I'll run you ten miles for punishment. We'll do our stuff. You do yours."

Lazy Lon looks sorrowful. He hates exercise. "Always in a hurry," he complains. "And just for a dance! I wouldn't walk across the street to be Greta Garbo's dancing partner. More fun to sit and rest."

"Your resting days are over if we miss the dance," Buck warns. "Now, highball. Take it out of here."

Lazy Lon does. But the breaks are against us. Maybe Sniffles has framed it with the night dispatcher to delay us all possible. I don't know. The fact is, it's 3 A.M. when we arrive there.

"Not so good," Buck admits. "However the manifest is on time. If we leave here by eleven-thirty, we can make it."

But we don't leave Coldwater at 11.30 A.M., because the manifest does not arrive until almost noon. On top of that Lazy Lon comes to report they've taken away our good engine and we're getting an old slide-valve, saturated hog that wouldn't run down hill unless pushed.

"We'll never get in now," Lon groans.

"We'd better," Buck says meaningfully.

Lon's face grows long but he don't argue. Just before our train pulls in, the switch engine grabs the caboose

and goes into the rip track to couple onto four cars of gasoline that evidently are there for repairs.

"Four hot boxes with rough journals and flat wheels," chuckles the engine foreman when Buck asks for information. "Mr. Sniffles Walker, acting chief dispatcher today, thought you boys ought to have something to worry about and work with on the trip."

"I told him they wouldn't run without new wheels," protests the rip track boss who comes up then. "But he says to turn 'em loose."

Buck snorts like he always does when he is getting peeved. It's a dirty trick on the part of Sniffles and to be expected. That train dispatcher is out to win the twenty-dollar bet with Buttons Brown and also take Mabel to the dance.

"Looks like we're whipped," says I. "Even with good luck we couldn't make it in now."

"We've got to make it!" Buck retorts grimly. "And we will! Sniffles thinks he has pulled something cute. I'll show him what cuteness really is. We're a long way from being whipped."

"And that gasoline will run hot," I go on gloomily. "All we'll do today is brass cars and fight hot boxes."

"We will worry about the hot boxes when we have them," Buck smiles. "Now, run along to the head end. I've work to do."

I'M at the engine when Buck shows up with the orders. Lazy Lon reads them and whistles off kind of mournful like. He's a long time getting the train under way, a pretty good sign it is heavy with tonnage.

"Eighteen hundred tons," Buck admits when I mention it. "Sniffles couldn't see any difference between a

slide-valve saturated engine and a superheater as far as tonnage was concerned. Good thing we got a level road to Kingston."

I agree with him. But after that comes hills galore. We probably will have to double the hills with that tonnage. I'm not very cheerful as I climb into the cupola to watch the train. But in spite of a heavy train we've moving right along. Laziness don't keep Lon from being a real hogger.

Going through the first town, I smell oily waste smoking. It's on one of the gasoline cars.

"Hot box!" I yell down to Buck. "On gasoline!"

"Fine!" he calls back. "We'll look into it at Fountain."

That's where we're meeting a passenger train. Buttons catches the caboose at the switch to inform us we got another hot box on a car of merchandise up ahead. By the time I get the switch closed and join them, Buttons has the jack and bar and brass and everything ready.

"You boys fix the merchandise car," Buck orders. "I'll look after the hot box back here. When you're ready, highball. Maybe you'd better take the water cooler to put on the box when brassed."

Personally, my idea would have been to put the cooler on the gasoline since it's a heavier load. However, no brakeman ever got anywhere arguing with his conductor. I say as much to Buttons, who agrees with me.

"And he knows what he's doing," Buttons continues. "You can bet on that."

I'm hoping so. We get the car brassed long before the passenger train shows up. The forty minutes' delay there sure puts a damper on Buttons' disposition. As we pull out I load the

equipment, but not before noticing that smoke is still pouring out of the hot box on the car of gasoline.

"Box seems pretty hot," I hint to Buck. "How was the brass?"

"Bad," Buck smiles. "And it'll be worse by the time we get to Kingston. So will the other four journals—or I miss my guess."

Buck is right. Every one of those gasoline cars has a hot box singing a tune by the time they've gone ten miles. And the black fog they send back over the caboose almost chokes me. But I don't get fidgety till one of them starts throwing sparks and fire clear off the right-of-way. Every moment I'm expecting a journal to burn off and put us in the ditch. I'm sure relieved when we stop at Kingston for water.

Buck doesn't seem at all bothered.

"Pretty good," he mutters, after examining the four cars. "They won't run. Set them out on the house track."

Now, setting out cars for hot boxes in them days was like handing in your resignation—unless you had good reasons. And we don't have good reasons, not with plenty of brasses and packing dope on the caboose. I'm thinking Buck is mighty foolish. I *know* it when the operator comes out.

"You can't set those cars out there," he tells Buck. "I was talking to the dispatcher and he says for you not to dare set out any cars for hot boxes, but to brass them and run them, regardless of delays."

"You tell the dispatcher I'm running this train," Buck says. "And any explanation needed, I'll make to the proper officials in the accustomed way."

Nerve? Sure, it was nerve. Buck had that to give away. Off goes the brass pounder. Pretty soon he is back.

"I told the chief what you said,

Slippery. He's reporting everything to Hackett and Fanning. They're over at Kline. You won't be so smart when they pay you a call. And don't think I'm going to alibi for you."

"I've got a sack plumb full of alibis of my own," Buck declares. "High-ball!"

AT the next station we get a message from Fanning demanding to know why we set out the gasoline cars instead of putting new brasses in. Buck replies that we have used all our available brasses.

That's a lie, the first one I ever knew Buck to tell. But under the circumstances I don't hold it against him. And yet—

"Suppose Fanning and the super come snooping around the caboos at Kline," I ask nervously. "If they find we got brasses they'll fire us all."

"I don't think so," Buck laughs. "The official mind works only one way. That's why I'm always two jumps ahead of them. I know what they'll do before they do themselves. Fanning and Hackett will ask to see the used brasses we took out of the cars, not the new ones we have."

"But we've got only one," I protest. "That's the one from the merchandise."

"You're mistaken," Buck corrects me, with a queer little smile. "We got *five* used brasses that size. You'll find them in a gunnysack in the oil cellar. I traded for them at Coldwater. The storekeeper there is a good friend of mine. If Sniffles hopes to keep us from the dance tonight, he's got to think up something better than hanging a lot of bad ordered cars on us."

Talk about shocks! I just about pass out, at this move of Buck's. But he told the truth, after all. The used

brasses are in a gunnysack in the oil cellar, just as he said. No wonder they call him Slippery Buck.

"Oh!" I exclaim after a look at the brasses. "I thought—"

"You thought I lied," Buck interrupts. "Only fools lie. The good general plans his battles before they're fought, not after the fighting starts."

That silences me completely. Feeling better, I climb back into the cupola. There is a smoke haze in the air, like a forest fire, but that don't disturb us none. With a lighter train Lazy Lon is shaking right along toward Kline. We're in fair shape and have a good chance of going into Pineville on time.

Then we stop at Kline. The first fellows I see are Superintendent Hackett and Trainmaster Fanning waiting for us. One look at Buck and they go into action.

"Anderson," Hackett says, all hostile like, "why did you set out those cars of gasoline after being told not to by the chief dispatcher?"

"Safety first," Buck replies nonchalantly. "Dangerous to run. Journals are rough. Brassing them is a waste of time, money and energy until new wheels are put in."

"But you didn't brass them!" Hackett barks. "You were not delayed long enough anywhere to brass any cars!"

"Forty minutes at Fountain while waiting for the passenger train," Buck reminds him. "Used all our good brasses right there. Angels can do no more, Mr. Hackett."

"You're a long ways from being an angel!" the super snorts. "But you're mighty close to being without a job, Anderson. This is one time you hang yourself. You say you brassed five cars at Fountain. Very well, I accept your statement. May I ask you to show me the five used brasses?"

The look on his face says as plain as words that he thinks he has Buck. Fanning is the same way.

"Why, certainly!" Buck turns to me. "Would you mind getting the sack we keep the used brasses in, and showing them to Mr. Hackett?"

I do. Hackett's face is a study when he sees the used brasses. However, he's not satisfied. Something tells the super he's being tricked, I guess. He finally has to give up after he checks the size stamped on the used brasses. The way he storms out of the hack does my heart good. Fanning stays behind.

"I don't know the answer, Anderson," Fanning grunts sourly. "But I'll never believe you brassed any five cars in forty minutes."

"I didn't," Buck confesses cheerfully. "My brakemen do that work."

"Fast men, eh?" the T.M. grunts. "I'll remember that in the future. Don't let me see any delay reports from you after this with more than eight minutes for the brassing of any cars."

**B**UCK promises. "Now you will excuse me," he says. "I want to get my train moving. We're taking in the trainmen's ball tonight at Pineville."

"If you do, you'll have to fly there," Fanning smiles. "There'll be no moving out of here for three hours or more. Maybe you don't know it, but there was a forest fire here and—"

Buck's jaw sags. "A forest fire? Yes, now that you mention it—"

"Yes," says the T.M. "Pretty bad one, too. It caught the yard office and depot here and darned near burned them down. Most of our records and instruments were destroyed. The fire was finally put out, though."

"So I see. But what does that do

to my train?" Buck wants to know.

"Nothing," Fanning replies, with a cunning twinkle in his eyes. "Only it'll be three hours before communication with the dispatcher can be restored. We have decided to tie you up until then."

Honestly, I believe Fanning was glad the depot and yard office were burned, since it gave him a chance to hook Buck.

"I don't suppose a train has ever been moved without a dispatcher?" Buck sneers. "I'm Number Seventy-two, a second class train—"

"And inferior by direction to Ninety-nine, which has not yet arrived," Fanning interrupts. "Have you any more brilliant ideas?"

"They'd be wasted," Buck sighs.

"Your sarcasm is not wanted, Anderson!" Fanning retorts angrily. "I don't have to look to you for any information concerning the movement of trains. There is no way to get you out of here. Mr. Hackett and I have discussed every possible way out of the situation and found none. Therefore you are tied up. And you can't tell me anything."

"I'm not going to try," Buck yawns. "If I did, you'd probably block any move I might make."

Fanning blows up. "No railroad official would block any legitimate and safe method, Anderson!" he snarls, shaking his fist at Buck. "You're slippery, I admit, but this is one situation you won't be able to slip out of. If you do, I'll buy you a box of cigars. I'll do more than that, I'll tip my hat to you every time we meet from now on, in recognition that you're a better railroad man than I am."

The conductor's eyes glisten like they do when he's ready to pull a fast one, but he doesn't say a word. What

Buck has in mind is beyond me. Anyway, he thinks too fast for most folks.

I trail him to the engine, where Buttons is close to tears. Motioning Buttons to come along, he cuts across the tracks to where a grocery store is. Back where the depot used to be, Fanning is watching us and laughing while talking to Hackett. Buck just smiles as I tell him this, and he goes into the store.

"Want to use your phone for a long distance call to Pineville," Buck tells the storekeeper. "I'll pay the charges."

"Sorry," replies the storekeeper, "but the wires are down. Forest fire, you know. The T.K.&P. Railroad superintendent and trainmaster tried to reach a dispatcher there. They wanted to get orders for a train."

Buck looks stumped. Plain to see he hadn't expected Hackett and Fanning to think of a move like that. No wonder they were laughing at us. Buck looks at the phone and frowns.

"That's one on me," he admits. "And Perley is a closed station."

Perley is a little town four miles from Kline. Nothing there but a general store with the postoffice. Of course, a dispatcher's phone is kept there in the blockhouse on the siding, where a conductor can get orders in a case of emergency. If we had been there Buck could have called and got orders. I said as much.

"That idea has already occurred to me," Buck says. "The question is, how are we going to get over there?"

"I can walk," Buttons offers eagerly. "Take a red flag and go ahead. You can follow. It will be slow—"

"Too slow," Buck objects. "I can do better than that. Wonder if we can hire an automobile and driver to take you over."

"We got a light delivery truck," speaks up the storekeeper. "My boy

will drive you for a dollar. He often takes drummers over there."

"Get him," Buck orders. "Now, to see if I can get the postmaster and Perley."

HE gets the postoffice, only the postmaster happens to be a *she* instead of a *he*. Buck says it's just to make sure the phone is working, and hangs up. Then he tells Buttons to get his red flag and torpedoes off the engine.

"Go to Perley," Buck says. "And call me from there as soon as you arrive. Then go out to flag and we'll come right over. Hold everything till we get there. I'll be waiting right here. What's your phone number, Mr. Storeman?"

"Forty-four," replies the storekeeper. "And here's my boy with the truck."

Buttons loses no time obeying Buck. Twelve minutes after the truck leaves Kline, the brakeman is calling from Perley. Buck pays for all calls and we hike to the engine on a dead run.

Lazy Lon blinks as Buck outlines the situation. "Does Hackett and Fanning know about this?" the engineer asks.

"No," Buck says. "A move like this would be too deep for their official minds, since it's not in the rule book. Anyway, you got a flag ahead for protection. That's all you're interested in. Now shake out of here."

Lon shakes out. Me and Buck catch the caboose on the fly. Once we get to Perley, Buck hurries to the phone to call the dispatcher. Right now, that smart boy wants to know how the hell we got over there.

"You wouldn't understand if I told you," Buck answers. "Give me orders to get out of here and make it speedy."



The only answer Buck gets to this is silence. I'm willing to bet Sniffles will hold us there as long as he can, just for spite. It looks like it for the next moment or two. Then suddenly the dispatcher's voice comes trembling over the line.

"Copy order."

"Shoot," Buck begs. "I'm waiting."

While Slippery Buck is copying the order, I go out and give Lazy Lon the signal to back up so Buck won't have so far to walk to deliver the orders. The engine is opposite the blockhouse when Buck comes out.

"The world is ours," he chuckles, shaking orders at me. "We meet Ninety-nine at Redtown and hold the main line. Explain that if you can, and you get the box of cigars Fanning is buying for me."

"I can't," I reply. "But I'll bet he's got a good reason."

He has. We learn that later. It's the same reason which keeps us from being delayed any more from then on. Six o'clock sees us in the yards at Pineville. Ten minutes later we're in the yard office. No sooner do we light there than the yardmaster hands us a message. It's from Hackett. Over Bucks' shoulder I read as follows:

**Take Condr. Anderson and crew out of service. Have them report my office tomorrow ten a.m. for investigation.**

I sigh. "Now, what do you suppose he has on his mind?" I ask Buck. "We didn't overlook anything, did we?"

"Not a thing," Buck smiles. "I've checked every move, and they're all foolproof. Don't you go to worrying and let it spoil your good time at the dance tonight. Come on, let's go home. Buttons is already there, I'll bet."

**B**UCK is all wrong. Buttons is at the beanery where cute little Mabel is giving him the wager money and a glad hand.

Up in the dispatcher's office Sniffles is looking out the window like he's lost his best friend. He's lost more than that, only we don't know it at the time.

"Just a moment, Anderson!" bellows a voice just then. "Want to talk to you."

Me and Buck stop. The next moment I almost swallow my chewing tobacco when I see nobody else but old Bulger Bascom, the general manager of the T.K.&P., waddling toward us. The way he's chewing on his fat cigar show's he's on the warpath. I take one look and move on far enough to be out of the way.

"Ah!" says Buck. "Glad to see you, Mr. Bascom."

"Never mind the fibs!" barks Bascom, taking the cigar out of his mouth and pointing it at Buck. "What do you mean by worrying my officials like you do and scaring them half to death by your wild stunts?"

The G.M. grunted. Before the conductor could reply, he went on: "And how in the hell did you get out of Kline today without orders or even a clearance?"

"By railroading," Buck replies, and goes into details.

Old Bascom puts the cigar back in his mouth and glares at Buck. "And who told you it was good railroading?" he snorts loudly. "One of your own ideas?"

"The idea is not new," Buck admits modestly. "An old conductor used practically the same method in moving his train, the Fast Mail, out of town under similar circumstances. The difference is he had to use a horse and

follow it over to the next town, while I used an auto and phones. They made a trainmaster out of him," Buck added slyly. "He's a general manager now."

"Well, I'm not making any trainmaster out of you!" Bascom declares. "God knows you give me enough trouble as a conductor. I'd be in a hell of a fix with an official that knew as much as I did. What I ought to do is fire you!"

"Mr. Hackett has already done that," says Buck. "We got the message at the yard office."

"Tear it up!" Bascom explodes. "When you're fired I'm going to have the pleasure of doing it myself, you scalawag. But it won't be for doing a damn good job of railroading. Now run along or you'll be late for the dance."

With which he shoos Buck away like an old woman herding chickens. By the twinkle in his eyes I know we're not losing our jobs. Honestly, the old gent acted like he was kind of proud of Buck and his stunt.

"I think I understand why we got orders at Perley without being delayed," Buck muses as he joins me. "Bascom was in the office at the time. And I'll bet Sniffles got a bawling out he will never forget."

Sniffles got more than that, as we learned later. He got notice from Bascom that he'd never become a chief dispatcher or any other kind of official. And a few months after that Sniffles Walker left the T.K.&P. to take a job with another road.

OH, yes, we went to the trainmen's ball that night. It was the usual big success. Buttons is so happy he can't talk. Mabel promises that night to be Mrs. Brown for life. So far she has kept her word.

"And I owe it all to you, Buck," Buttons chokes his thanks. "I'll never forget what you've done for me."

Buttons isn't the only one who was never to forget. Fanning is another. He buys the box of cigars for Buck the next day when Buck meets him on the street and reminds him of it. Fanning buys with bad grace and then starts off, only to have Buck call him back.

"You've forgotten something else," Buck reminds him, at the same time touching the brim of his hat. "Remember?"

Fanning glares for just a second at Buck. Then he grins. His hand goes up to his hat. The trainmaster is a better sport than I thought he'd be.

Every day

Enjoy

Beeman's Gum

... A I D S D I G E S T I O N



# The Sunny Side of the Track

## HE REFERRED A PAY CAR

**B. F. SMEATHERS**, veteran clerk on the Wabash at Decatur, Ill., likes to tell the story of an Irish section hand on the Mo.P. who was asked by a labor organizer to join the American Railway Union which Eugene Debs sponsored forty years ago.

"Does this man Debs have a pay car?" asked the son of Erin.

"No," replied the organizer.

"Then I'll stay with the Missury Pas-sific," the section hand replied.—Decatur Review.

\* \* \*

## A SURE SIGN

**HARVEY HOUSE WAITRESS**: "I must take a vacation. I'm afraid my beauty is beginning to fade."

Manager: "What makes you think so?"

Waitress: "The switchmen are beginning to count their change."—Dana Mavity.

\* \* \*

## SAFETY FIRST

**SURGEON**: "Shall I give you a local anesthetic?"

Pullman Conductor: "Well, doc, if it's going to hurt, I reckon you had better cut out the local and run me through on a sleeper."

\* \* \*

## HOGHEAD'S DYING REQUEST

**A HOGHEAD** on his deathbed lay; His life was ebbing fast away. His friends around him closely pressed To hear the hogger's last request.

He said: "Before I bid adieu  
One last request I'll make of you;  
Before I soar beyond the stars  
Just hook me on to ninety cars.

"Oh, let me on that engine there,  
Just see how rough I can handle air!  
Oh, let me at some water tank  
Make a big-hole stop and give a yank!

"Then from the corner of my eye  
I'll watch the pieces as they fly;  
Then I'll calmly, softly sit me down,  
And watch the dust-clouds settle round.

"Oh, let me pull a drawbar out,  
And take my can with its long snout,  
And get me down upon the ground  
And take my time to oil around.

"Then far behind in that red caboose  
I'll hear the conductor turning loose  
A few pet names, as in days of yore  
I've heard a thousand times before.

"Oh, just once more before I'm dead  
Let me stand the conductor on his head;  
Let me see him crawl from beneath the  
wreck,  
With a window sash hung 'round his neck.

"And you, dear friends, I'll have to thank,  
If you'll let me die at the water tank;  
Within my ears that familiar sound,  
The tallowpot pulling the tank spout  
down.

"Oh, let the train with drawbar down;  
Have all the crossings blocked in town;  
And when they chain those cars together,  
I hope it'll be in sloppy weather.

"And when at last in the grave I'm laid,  
Let it be in the cool of the water tank  
shade,  
And put within my lifeless hand  
A monkey wrench and the old oil can.

"A marble slab I do not crave;  
Just mark the head of my lonely grave  
With a drawbar pointing toward the skies,  
Showing the spot where this hogger lies."

Then fainter grew the hogger's tone;  
His friends around him began to groan.  
His mind was wandering far away,  
Perhaps to some other bygone day—

When he as a hogger of great renown  
Was turning cabooses upside down;  
Perhaps his mind was wandering back  
To a drawbar close beside the track.

While he was trying to start the train  
And was doing his best to "break the  
chain."

Then his face lit up in joyful light  
And his soul prepared to take its flight.

His friends called to him in sad refrain.  
He smiled and said: "I've broken the  
chain."

Then closing his eyes, he said no more.  
He was "doubling the hill" to the other  
shore.

—Henry McNamara.

**A GOOD** apple set beside a rotten one never makes the rotten one good. Low wages placed beside high wages rarely pull themselves up to the high. No matter where you work and what you do, if you have a job and want to maintain your wages, or if you haven't one and want to earn decent pay, you will be vitally concerned with the low wages being paid to some transportation employees. This article tells about them and how they affect you.—The Editors.

# Highway Robbery

By GEORGE L. PHILLIPS



THE American standard of living is still said to be, despite the Depression, the highest in the world. An American citizen can buy more with what he gets than anyone with a similar job in any other country. The big reason for taxing articles imported from other countries is to prevent poorly paid foreign labor from underselling better paid American labor, who would thus be forced out of their jobs. The same principle applies in our own competition. When the Depression came cut-throat competition whittled wages down in many industries. One of the first acts of the Roosevelt administration was to recognize that fact. It established, through the N. R. A., uniform minimum wages for industry.

Such has been the theory and such has been the policy—for every industry except transportation. In this industry trucks, busses and waterways are allowed to get away with plenty when it comes to paying their employees—even more than they get away with plenty in the matters of regulation and taxation. The railroads, however, pay good wages, fixed by negotiation with the management, under provisions carefully legalized.

The Government has done nothing to protect railroad wages from competition of other transportation workers, all of whom work for a fraction of railroad wages, and some of whom get practically nothing. Indeed, the N. R. A. itself *approved of* mini-

imum transportation wages which are far below the standard of railroad wages. Perhaps we can't blame this state of affairs entirely on the Government. It may not have had time to go into the matter. Probably it will act on it as soon as it can. What you can do about it I'll tell you in a minute or two.

To be fair and honest, I will admit that the truck, bus and waterway people probably pay good wages to some people. Darn good wages, in fact. Can you guess who these people are? Well, they are the boys down in Washington, hanging around and making it their well-paid jobs to see that Congress and the Administration appreciate their industries. And there are plenty of them, too. They are rewarded for economically wasteful work in behalf of an industry which itself represents waste in transportation.

Official figures on the pitiful wages paid to motor transport labor are pretty scanty just now, but you yourself can look around and see how pitiful they really are. Why, even the motor wage scales compiled almost two years ago by the Bureau of Labor Statistics showed the average inter-city bus driver received less than 60 cents an hour and worked more than 51 hours a week, and the average inter-city truck driver worked more than 53 hours a week for \$25. The point here is that these figures do not include the railroads' and the nation's worst enemies—the wage chiselers who operate independently, the fly-by-



Three More Were Added to 1934's Highway Injury List When This Greyhound Bus, Running Late between Boston and Buffalo, Slid down a Hill in Syracuse, N. Y., over a Bridge and into a Creek. The Bus Started Skidding When the Driver Swerved out of the Way of a Giant Tractor-Trailer. Last Year Was the Red-Letter Year for U. S. Highway Accidents, Almost a Hundred Were Killed and More Than Two Thousand Five Hundred Were Injured, on the Average, Every Single Day of the Year!

nightriders who load their ramshackle trucks and busses far beyond capacity; the highway robbers who have brought the travel standards of America down to those of a hundred years ago and the living standards of their employees below those of good, civilized horses.

Is this an exaggeration? Not at all. I know of one truck outfit that doesn't pay wages. It simply gives a man his "board and room" (and what a board and room!) in return for 16 hours or more a day of back-breaking, brain-splitting labor. Talk about highway robbery! I know of one cut-rate bus company which, in freighting its passengers from New York to Chicago in 34 hours or more, provides them with the worst experience of a lifetime and dumps them out exhausted and demoralized, mentally and physically. Last January 25th, 15 passengers on a through New York City-Chicago bus were over-

come and one was killed by carbon monoxide gas from the exhaust, when the bus was only a dozen miles out of its terminal. These are extreme examples, but they are examples of the things which bleed our transportation system the most, and which cost more in the long run than railroads.

**E**VEN the reputable truck and bus companies pay miserable wages when compared to those of railroad men. They admit it. Indeed, they defend their position. They claim that if they paid the railroad wage scale they'd be forced out of business! I ask you, gentlemen, ain't that just too bad? Why, if the trucks and busses represent transportation progress as they claim they do, they should be able to pay *twice* as much as the railroads pay, especially in view of the fact they aren't charged anywhere near enough for the roads they run on.

Get me right on this. I don't exactly favor equal wages for highway and railroad men. Not under present conditions, anyway. The type of men who operate our trains cannot be compared with the average run of fellows to whom bus and truck owners entrust their vehicles.

Nevertheless, the difference should not be as great as it is. The coolie, even though he may not be as good a man as an American worker, could still put the American out of a job if he were allowed to compete. Suppose American automobile manufacturers imported enough coolies to man their plants and paid them half the wages they pay Americans. Automobiles would cost about a third as much as they do. But wouldn't we howl? Then let's howl about the coolie system right here at home, in the transportation business.

A man who takes a heavy bus or truck out on public highways at passenger train speeds has a tremendous responsibility. He ought to be experienced, fit, and as good in his work as railroad men are in theirs. His hours and rest are as much the public's business as are the hours and rest of railroad employees. No matter how you look at it, it is as much the duty of the Government to do something about this as it has been the Government's right to set standards for railroad labor.

These standards must be screwed to all commercial highway traffic. They must be screwed tight, to prevent chiseling. Of course, a farmer hauling his own produce, and so on, can be exempted. But the truck

engaged in inter-city haulage is a commercial enterprise, whether the operator works for another man or hauls his own goods, and the same requirements for qualifications, hours of duty, and wages should hold.

Don't think for a second that this will come about naturally, as it did in the railroad game. There are too many men out of work for bus and truck employees to strike for more pay and less hours. They probably wouldn't get to first base. The only way they can be helped is by outside intervention.

Competitors of railroads have been able to turn the transportation clock backwards because they have not been checked on three counts: (1) they have not been regulated as railroads have been; (2) they have not been taxed nearly enough to pay for their expense in road construction and maintenance; (3) they have not been required to maintain working conditions and wages anywhere near equal to those maintained by the railroads for comparable work. And the greatest of the three, so far as you and I are concerned, is the last.

Get in touch with your Senators and Congressmen and tell them about the new highway robbery. Don't be afraid to express yourself. If you are a railroad man, your whole future depends upon what the Government will do about it. If you are just an ordinary citizen, you can't afford to let wage standards in the transportation business slip. Once they are down, yours will come down, too.

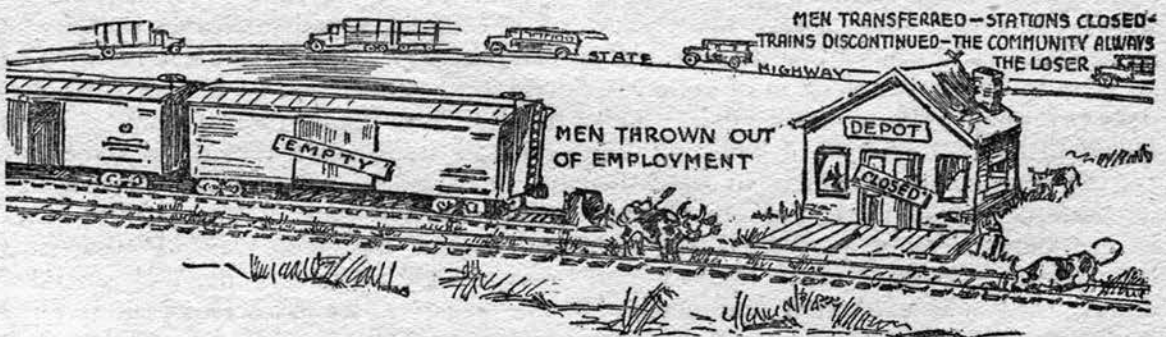

*Courtesy Kentucky Railroad Employees' and Citizens' Leagues, 205 S. 4th St., Louisville, Ky.*

When a Railroad Line is Abandoned the Community Served by It No Longer Receives the Benefit of High Railroad Wages; It Gets Only Highway Wages Amounting to a Quarter as Much

# 36 Miles in Three Days

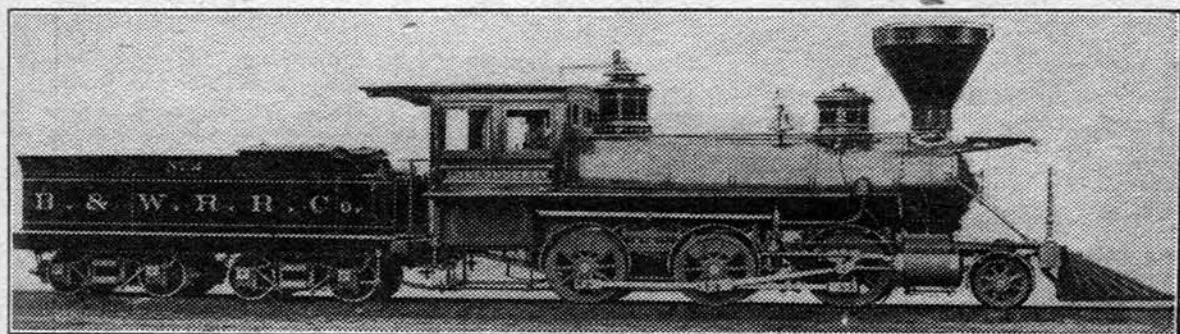

*Photo from Joseph Lavelle Collection*

No. 2 of the Brattleboro & Whitehall, an Old Danforth-built Mogul with 12 x 16 Cylinders and 37½-Inch Drivers. She Later Became Central Vermont No. 192

**T**HE West may brag about some crooked pikes, but the Brattleboro & Whitehall up in Vermont had them all beat. This little road was, at the time, three foot gage. It was only 36 miles long, and 33 miles of them consisted of curves. You could ride 3 hours, from one end of the line to the other, and still you wouldn't be a long way from where you started.

The rails were 30 pounds to the yard, and the road bed, especially during the spring, was mud and more mud. The bridges were a tribute to the engineers of the Civil War Period. Early in 1905 I made a trip over this pike, and the last bridge we passed over collapsed just as the rear car cleared. On many trips previous it was not uncommon to watch the ties drop from the bridges and splash far below in the little river that followed the railroad most of its length.

Despite its shortness, the line enjoyed quite a business until a few years ago, even if most of the trains consisted of wreckers. Half a dozen derails a day were not at all unusual. One trip I made took 72 hours to complete the journey. We left Derry headed for Brattleboro, the latter our terminal. It was snowing hard and our engine was having a tough time getting along through the hills with our six cars and buggy. As we approached the "Cork Screw" curve, all drivers and the tender trucks sank into the snowy ground.

The dispatcher was notified. He said we'd have to stay there or try to re-rail the engine ourselves as the wrecker was also on the ground just north of Brattleboro. Great news to the crew, but with much cursing we began to re-rail the little engine.

After struggling six hours we had the mill half way on, but had to quit and shovel snow into the tank as the water was low. I shoveled snow before but this time I thought I'd never get enough into the tank. I bet the crew must have spent all night trying to fill the tank up. We finally succeeded in getting her on, and with enough snow melted in the tank to carry us to the nearest water plug, we started.

At Windhall we had to pick up a car of lumber. The car stood on a spur track that dropped down a steep incline toward a saw mill. The engineer backed down O. K. but the little goat couldn't get the car up out of there. Finally we decided to leave the car.

That being settled, I gave the engineer a go ahead signal, but he didn't go far. The engine failed to get up herself! Without engine we were licked. The fireman dumped the fire. The crew walked back to the station and notified the dispatcher of our mess. We were greeted with orders to tie up as best we could, and relief would come through in the afternoon. The snow got so deep during the day that the road was tied up the next day. It was three days later when we reached Brattleboro.—Thos. F. Sisk.

---

Next Month: "The Traveling Grunt," by Earle Davis

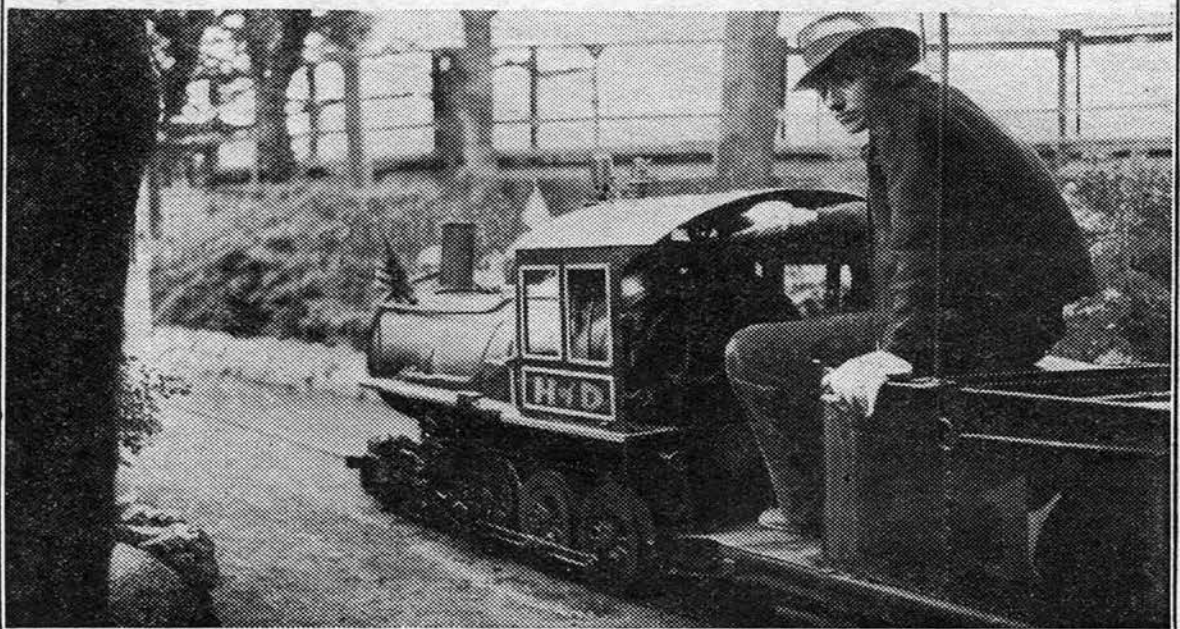
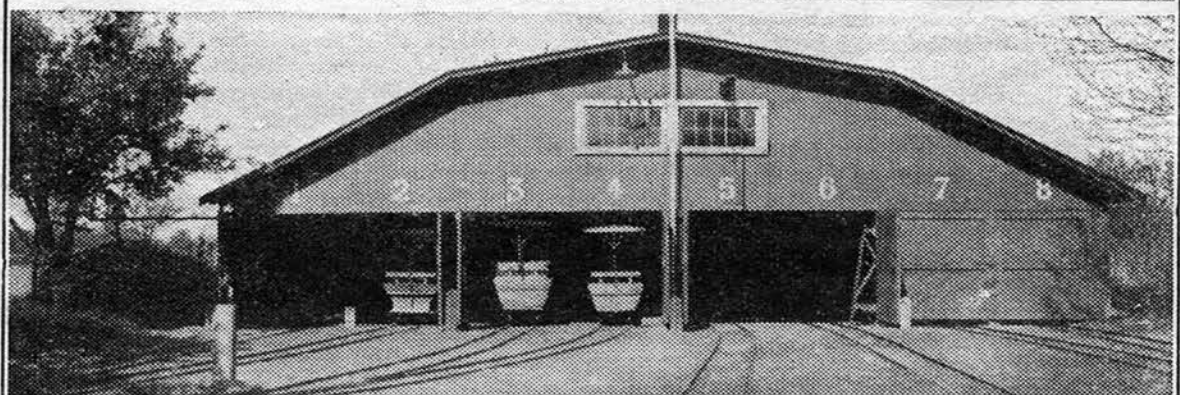
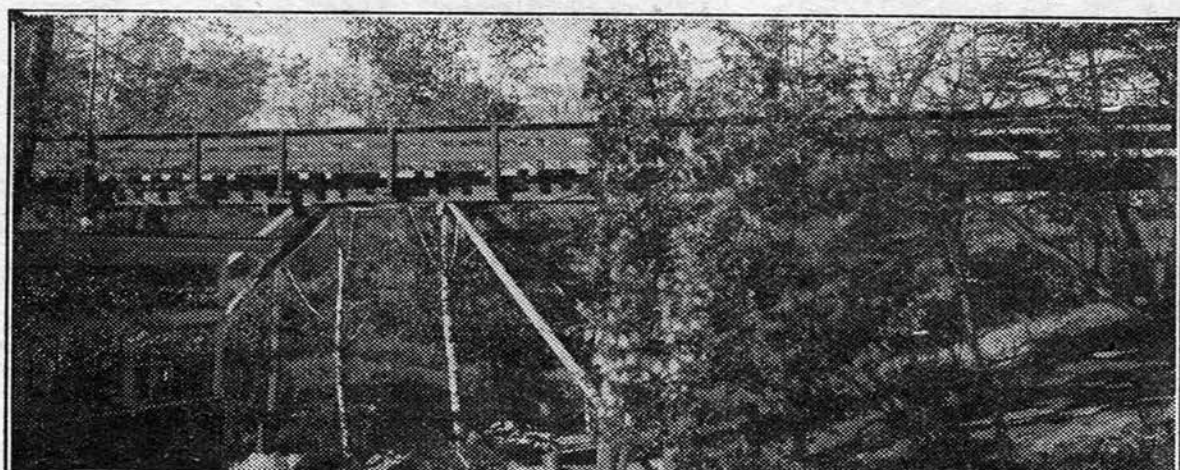

On the House of David Right-of-Way. These photos, Taken by R. B. White, Show a Miniature Railroad Trestle, the Engine House, and a Young Hogger Running H. of D. Locomotive No. 1



# House of David Railroad

By FREEMAN H. HUBBARD

Editor of "Railroad Stories"



ONE of the strangest railroads in the world is a narrow-gage pike a mile long at Benton Harbor, Michigan, owned and operated by the House of David. The House of David is a religious cult known to the public largely because its men wear long hair and beards after the fashion of Galileans in the days of Christ. A safety-razor salesman in that colony would starve to death.

The road has eight locomotives. All were built in the H. of D. machine shops twenty years ago and are still running. These engines are as near like standard-gage power as they can be made, even including air brakes, bell and steam whistle. All are steamers and burn coal.

Nos. 1, 2, 3 and 4 are 4-6-0 types, while the others are 4-4-0's. Each of the 4-6-0 types weighs about 2200 pounds, and each of the others about 1800. Each carries 150 pounds of steam, but instead of the single large headlight used a few years ago she now has *two* electric lights.

The track is fifteen-inch gage and runs over two high bridges and through fifty acres of beautiful park and orchards. Real little rails, track spikes and oak ties are used, with guard rails on all curves. Crossings are protected with gates manned by long-whiskered railroaders. There are about a mile of main line tracks and a mile of sidetracks leading to the roundhouse, etc. This is a real miniature roundhouse, with the number of each engine over her stall.

Trains consist of eight cars apiece, except the work trains which, like those on the big roads, have as many flats and other cars as are needed. The trains are used also to haul members of the colony to work, and to clean up rubbish around the park.

"Usually boys are employed as engineers, as they are popular among children who patronize the road," writes R. B. White, of Drayton Plains, Michigan, who supplied some of the facts in this article. "However, when the conductor came for my ticket I found he had enough 'seniority' on his chin to work for any railroad."

White, who is a section foreman on the Grand Trunk Railway, asked one of the H. of D. rails if he could get a job on their pike. Believe it or not, the man felt White's chin and shook his head "No."

The streak o' rust is only one of many enterprises which the House of David conducts. This cult acquired more than 1000 acres of land, city blocks, docks, boats, factories and many buildings, totally valued at millions of dollars. At one time, in addition to the railroad, they owned and operated a street car line between Benton Harbor and St. Joseph, and two steam vessels, besides raising garden produce and selling it in the open market, making and selling many useful articles.

The colony is really a little city in itself—an industrious and self-sustaining community. Its founder, "King Benjamin" Purnell, was born in Kentucky in 1861, ruled for twenty-four

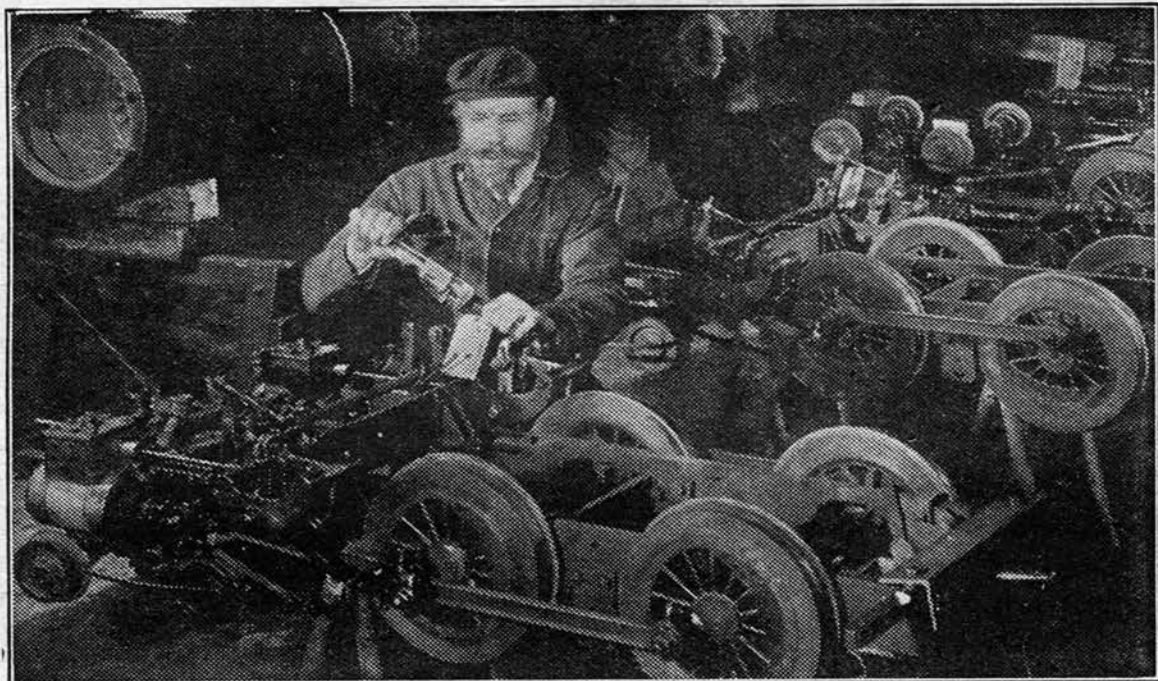

*Photo from Eden Springs, House of David, Benton Harbor, Mich.*

Scene in the House of David Machine Shop, Showing a Railroad Machinist at Work on the Valve Gear of One of the Midget Locomotives

years, and died in 1927. At one time this group in Benton Harbor numbered more than 700 men, women and children—in addition to a multitude of others said to have been scattered throughout the world—but this total has dwindled considerably since the leader's death.

King Ben claimed that he himself was without sin and would live forever, and promised immortality to his devotees. Members of the sect, some of them wealthy, turned over all their property to the House of David and agreed to work without money in return for food, shelter and clothing supplied by the management.

Rule G and Rule H are part of their religion; members pledge themselves not to drink alcoholic liquor nor smoke tobacco, nor even eat meat. Their favorite hobbies are music and baseball. House of David orchestras and ball teams have made extensive tours

of the country and attracted much comment.

King Ben was known as the "Seventh Messenger Angel of the King of God." At first he announced that the Day of Resurrection would be "the longest day in June, 1906"; but when June, 1906, came and went without any blowing of celestial trumpets he explained his prophecy by saying: "A day is as a thousand years in the sight of the Lord."

The "Messenger Angel" lived in a palatial mansion which he called "Shiloh" and was reputed to have had numerous girl attendants. In fact, he got into legal difficulties for this reason. There was a sensational exposure of the colony in the courts some years ago and King Ben himself went into hiding. But in other respects he was a born leader, a brilliant organizer. He taught that everyone should practice some form of creative activity. As

one writer said in the *New York Times* of April 22, 1923:

"A man must have a remarkable personality to induce some 700 men and women to take their families to him, sign away all their property and live as serfs. . . . Benjamin is dominant, magnetic, almost hypnotic."

For years after Purnell's death his mummified body lay in state in an upper front room in the "House of Diamonds," watched over by faithful devotees looking for the glorious day of his resurrection. Possibly the body is still there. It is said to have been treated with a special process which

makes it hard as stone, and was wrapped in white linen set off with gold and diamonds.

Rumor whispers that nearly a million dollars in jewelry is hidden in that upper-story room with the body, guarded by armed men. Whether this is truth or legend is hard to say. At any rate, the mysterious colony at Benton Harbor is well worth a visit. It's quite a thrill to ride on the H. of D. Railroad, and the cost is only 25 cents a round trip. Unlike the procedure on big roads, the conductor will punch your ticket twice and give it back to you as a souvenir.

## Solving a Wyoming Mystery

ONE of the toughest stretches on the U. P. used to be through a valley in southern Wyoming called the "Hole in the Wall." Here hung out professional bad men—specialists in cattle rustling, safe-blowing, train wrecking, etc. Train robberies became so frequent that in 1902 the U. P. sent for Timothy T. Keliher, a former Nebraska sheriff, made him their chief special agent, and said: "Robberies must stop. Take what men and equipment you need and go to it!"

Keliher went to Cheyenne, picked a posse of ten. They were all fancy shots—could hit the ace of spades flung in the air, and so on. Three of them were the best trailers in the West. Keliher commandeered an old passenger coach and converted it into a rolling arsenal. At one end were quarters in which the men ate and slept. At the other end was a stable for their ponies. He arranged that the pursuit car should have right of way over all other trains, and stood ready to take after bandits on a moment's notice.

One night the wires began burning up from Green River: "Outlaws held up pumping station at Williams. Shot pumper through the arm and smashed a switch so as to wreck train. Pumper left as dead, crawled to a phone and called Green River, halting train long enough to get switch fixed up."

Keliher appropriated a locomotive; he and his men highballed west. It was their first call. At Williams, a parched desert spot near Green River, they found nobody, for the pumper had been taken to a hospital. Near the smashed switch Keliher found a trail of blood leading to the phone inside the pump station. He picked two of his best man-hunters; sent one three miles to the north, the other three to the south. These men slowly spiraled in toward the pump station, moving in opposite directions.

"No tracks," they both reported.

That gave Keliher a hunch. He told his men to get in the car, and the locomotive pulled them back to Green River. At the hospital he found the pumper doing well and apparently pleased with the attention he was getting.

"You were alone out at Williams, weren't you?" he asked kindly. The pumper looked at Keliher suspiciously, admitted he was. "I've heard," said the chief, "that a man who was lonesome enough would do anything—even shoot himself—to get a little notice. How about it?"

The pumper looked suddenly very tired and disappointed. "Yeah," he admitted, "the bandit story was pure fiction."—Jim Holden.



# International Engine Picture Club

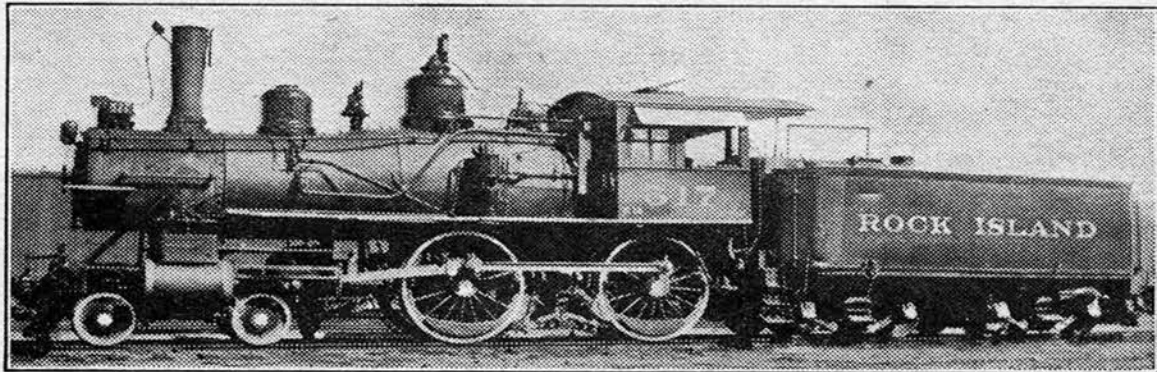

This Interesting Old Eight-Wheeler, Snapped by Wesley Krambeck at Chickasha, Okla., Was Originally Choctaw, Oklahoma & Gulf No. 26, Then 39, Next Rock Island No. 417, and Finally (1924) No. 517

## Helpful Hints on Locomotive Photography

**D**URING the last four years, and especially the past few months, members have been sending us a lot of interesting engine photos. Most of them are surprisingly good, despite the fact they were probably taken with small inexpensive hand cameras. However, we've noticed that many of them were made from negatives which obviously could produce better prints than the ones we saw; that many pictures would have been improved if they had been given longer exposures, or if the camera diaphragm had been "stopped" down to insure sharp focus and the exposure made still longer. Here, then, are a few simple rules to observe:

(1) Get your engine straight in the finder; make sure it isn't tipped to one side. A good way to do this is to notice the upright lines of the cab and tender and see to it that they are parallel with the sides of the finder.

(2) Focus properly, if your camera has a focusing rack; and "stop down," if it is equipped with a stopping device. "Stopping down" is closing of the "eye" of the camera so that the opening is smaller and less light enters. This, of course, means longer exposure, but sharper negatives.

(3) Give plenty of exposure, especially if you "stop down." Try to take your engine pictures on a sunny day, and even then give them more time than you would ordinary subjects. If necessary, buy or make a tripod or camera stand, so that if you have to you can take exposures of more than  $1/25$  second (never give more if you are holding the camera) after you have stopped down. A little experimenting will soon enable you to determine when you have enough exposure.

(4) Try to develop your own negatives and print your own pictures. If you can't do the former, at least print your own. Once you get the hang of it—and anybody can—your prints will be sharper and cleaner, will last longer, and will cost about one-fifth as much as commercial prints.

(5) Keep your lens clean.

Among the hundreds of members who take good pictures we picked a couple who have been sending us unusually good prints. They are Robert Graham, 872 Union St., St. Paul, Minn., and Wesley Krambeck, Herington, Kan. Both use ordinary cameras, but each has produced prints which were far ahead of many professional "company" photographs. We asked them to tell us something of their photographic

technique, and they responded with a lot of useful information. If you have any trouble with your pictures, it will help you. Mr. Krambeck, for example, says:

"I always try to take front side views; that is, a broadside with a little of the front end, too. I get as close as I can but am careful that I have the whole engine in the picture. My camera is a plain box camera, with a single lens of the same speed as all box cameras. (Editor's note: about f:16). It uses size 130 film (2-7/8" x 4-7/8"). It has no attachments and there isn't anything unusual, fancy or modern about it, as I have had it for over ten years. I keep the lens very clean at all times. While the shutter has no variation of speeds, with the use of fast film I have taken a number of pictures in cloudy or bad weather which might be considered good or fair. Sometimes I can get a moving engine, if I stand to the front and it isn't moving too fast.

"I use Agfa Ansco Plenachrome film exclusively. I have found it far superior to others in locomotive picture taking, for it is not only a very fine grained film, but it produces clear, sharp, contrasty negatives. The last quality is very important in engine pictures.

"After I became interested in taking locomotives I soon found that having my developing and printing done was going to be extremely expensive. Then, too, all pictures which commercial photographers had made for me faded or turned brown within two years. So I decided to do my own printing, but continued to have my films developed by commercial photographers for about three years after I started doing my own printing. However, I had a great deal of trouble getting good work on the films. They would develop them in old solutions (which gives the same results as exposing a film and then letting it lie around for several months before developing), scratch them and tear little chunks of emulsion off, and would not wash them clean. I got such unsatisfactory results I decided to do my own film developing, also.

"I develop in the bath room after dark.

For a dark room lamp I use merely a drop cord from the ceiling socket, with a 10-watt red bulb. However, to make sure the film does not absorb any of the red rays from the lamp, I place a cardboard shade over the lamp on the side toward the film. Plenachrome film is very "fast," so I use just barely enough red light to see at all. For the developer and fixing bath I use a couple of small bowls or enameled pans.

"To develop the exposed film I unroll it, run it up and down a few times in clear water to soften the film, make it easy to handle, and do away with air bubbles. After that I take the film to the developer and run it up and down through that solution about four minutes. Then I put it back into the water and quickly rinse the developer off. Next, I run the film up and down through the fixing bath for at least 10 minutes. I work the film up and down in it not less than twice as long as it took to develop it.

"After the film is fixed I wash it. To avoid wasting a lot of water and to save myself time I had a small galvanized tin tank made. It cost \$1.50, is 7" wide, 22" long and 3-1/2" deep. It will accommodate two rolls of films at one time. I do not have to touch the films until they are completely washed. This eliminates the possibility of scratching, although I wash them at least six times and let them soak two minutes between washings before draining and running fresh water into the tank.

"I made a film drying frame out of yardsticks, bolting them together and carving a long slot in each stick at one end of the frame. After the films are washed I clip them to this drying frame with clothes pins, fastening both top and bottom of the film to the rack, leaving no slack in the film. Then I stand the rack up against the wall, so the films will be hanging ends up and down, and let them dry overnight. They turn out exceptionally clean and smooth, with no dirt or water spots.

"For developing Plenachrome film I use Ansco M. Q. tube powders. A 6c. tube makes 8 ounces of developer merely by dissolving in water, and is enough to develop

two rolls of films. A number of other developers can be used satisfactorily, too.

"My printing equipment consists of a medium-sized box lined with white paper and equipped with a 75-watt electric lamp, a printing frame with adjustable mask, a small tin dark room lamp which I equipped with an electric lamp (15-watt white lamp behind red glass), one small enameled pan for developer, a good-sized dish for clear water, and an ordinary dish for fixing bath.

"For developer I use Eastman M. Q. tubes, for fixing bath Kodak fixing powder. As the temperature of the developer varies according to weather conditions I always test a picture or two when starting in order to judge the approximate exposure required. After that, I expose 6 or 8, then run them through the developer and repeat until through. I time the exposure by counting in my mind, rather than by a watch. I try to give just enough exposure so the picture will come out steadily, and will be fully developed in about a minute and a half.

"After the picture reaches a certain point I take it out of the developer, letting the developer drain from it back into the pan, and hold it up to the red lamp until it gets exactly where I want it. Then I quickly rinse it in clear water and place it in the fixing bath, where it remains not less than 15 minutes. If I underexpose and the picture comes out too slow or overexpose and it comes out too fast I throw it away. I now have my system down to a point where I can almost without fail judge the exact exposure. With a tube of M. Q. developer, by draining the developer from the picture back into the pan, I can make from 75 to 80 pictures per tube.

"I use Eastman Azo "F" No. 4 papers exclusively for all engine pictures. This is a slow, hard paper and intended for flat negatives. However, I have found it satisfactory for *all*, since it produces black and white effects. This is very important in getting good engine pictures. If a negative is so dense that printing on No. 4 paper will produce chalky effects, I use No. 2 paper, as I have found the No. 3 tends to produce greenish effects.

"After the pictures are properly fixed I wash them at least 6 different times, permitting them to soak at least two or three minutes between washings.

"When they are washed I place them on the 'ferro' plates and lay a cloth over them, running a print roller lightly over the cloth to take up excess moisture, then remove the cloth and roll them with the print roller. I use a small 4 inch roller, as it enables me to give each picture proper attention.

"In hot weather I try to keep my solutions as cool as I can, but often I have to cut down the exposure to conform to the increase in developer temperature. This is against the rules, but I have good results.

"Although I print 60 to 80 pictures in an evening, my system of using a fairly slow light, hard papers and allowing developer sufficient time to act on the papers by proper exposure, is not as fast as it might be. However, I prefer to take a little more time and get good results than to hurry and get poorer results.

"I buy my supplies in fairly large quantities. The cost for developing each roll of film averages about 6c. per roll, for making each print approximately 1c. per picture, including cost of light, water, etc."

We've seen at least 50 of Mr. Krambeck's better prints, and they are equal if not superior to many we ourselves have taken with cameras equipped with sharp anastigmatic lenses. The big secrets of Mr. Krambeck's work, we believe, are his careful photography in plenty of sunlight, developing his own films, and printing his own on hard paper to provide contrast and bring out detail. Note how what he says fits in with the advice of Mr. Graham:

"I have an ordinary Eastman 116 size Kodak with an f:6.3 lens. The great majority of my pictures are taken with f:11 in good sunlight, and f:8 or f:6.3 are used as needed. I nearly always use a speed of 1/25 second, although in cases of poor sunlight or where the sun is too low in the afternoon, I sometimes use 1/10 second. The 1/50 and 1/100 speeds are only for moving trains. I use a focus of 25 feet.

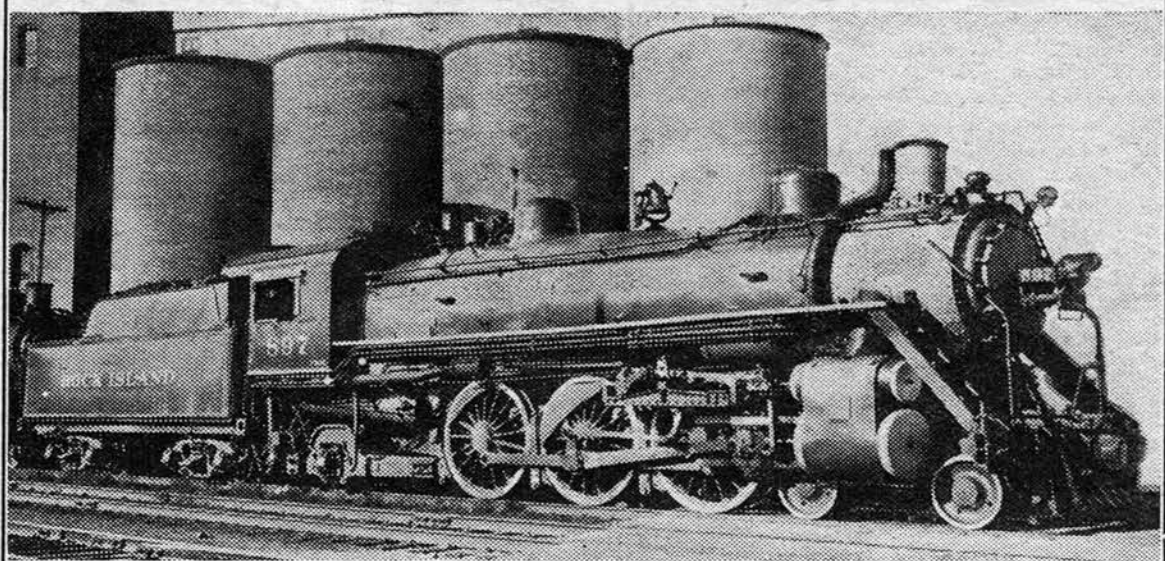
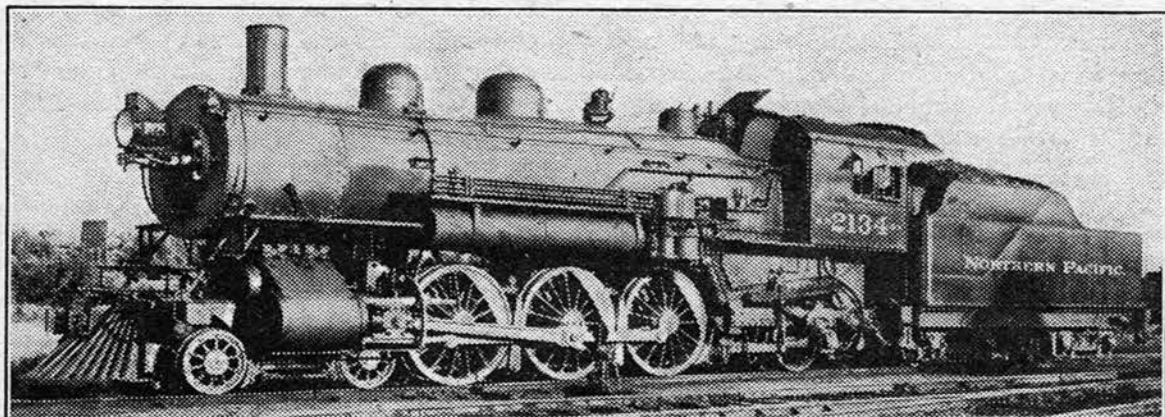

Northern Pacific No. 2134 and Rock Island No. 897 Snapped by Robert Graham in the Twin Cities

"I keep my lens clean. A railroad yard is not the cleanest place there is, and with smoke and soot in the air, a lens is bound to become dirty. I not only wipe off both sides of the lens every time a film is replaced, but carry the kodak around closed, opening it only when a picture is to be taken. In taking a picture I hold as still as I possibly can, and hold my breath as the picture is snapped. I have never used a tripod, although with a speed of  $1/10$  I like to steady the kodak against some object, if convenient. (Editor's note: Most people cannot hold still longer than  $1/25$  second.

"As for film, I always use Agfa Plenachrome. I do not say it is best, as I have taken many good pictures with others, but

I believe Agfa is much better for engine pictures, since it shows up detail, and has more contrast.

"I do not develop my own film, as I have a photographer upon whom I can depend. But I make all my own prints, using Eastman M-Q developer and Kodak fixing powder. In printing I try to *under-expose* very slightly rather than *over-expose*, as this causes the picture to come out more slowly in the developer and gives a better opportunity to catch it at just the proper time. I use Azo F No. 4 paper. It brings out detail better than a softer paper, and detail is the big thing in engine pictures.

"One more item: the position of the sun. I take many photos in summertime from 6 to 9 A. M. and from 3 to 6 P. M., when

the sun is lower and shines on the wheels and under parts. At noon they are all buried in shade. The same is true even when slightly cloudy. When it is very cloudy I don't take engine pictures.

"Good clear air is important. The accompanying print of N. P. 2134 was taken late one afternoon when the sun shone after a heavy wind and rain storm which had cleared the air."

**R**eaders who collect, buy, sell, exchange, or make pictures of locomotives, trains, cars, etc., are listed here as members of the International Engine Picture Club. There are no fees, no dues. Names are published in good faith, without guarantee.

A membership button is given FREE to those who send in a "Readers' Choice" coupon (page 143) and self-addressed stamped envelope. (If you live in Canada or any foreign land, enclose a loose 3c stamp from your own country instead of the envelope.) Address Engine Picture Editor, "Railroad Stories," 280 Broadway, New York City. Tell him what you want or what you offer.

**R.** L. ALDINGER, Box 76, Randolph, O., has interurban, steam timetables; wants abandoned electrics of Ohio, Ill., Ind., Mich. and OR&W; buys snaps of Ohio, Ind., Ill. electrics; send stamped self-addressed envelope for list.

J. B. ALLEN, 1761 E. 90th St., Cleveland, O., trades other copies "Railroad Stories" for Oct. '30, Sept. '31 and all issues before Sept. '30.

C. H. ATKINSON, 51 Commercial St., Penacook, N. H., has B&M engines of 1908; wants B&M No. 783 (later numbered 3200), 2900 series and Pikes Peak Ry. engines.

H. O. BAILEY, 811 Cherry St., Philadelphia, Pa., has 8 x 10 of NYC streamlined engine at 40c ea.; 3 for \$1.

A. BAUER, R. 2, B. 354A, S. Bend, Ind., has photos NYC wreck in S. Bend, trade for other wreck pictures.

E. BECKER, 2422 W. Franklin St., Evansville, Ind., starting; send lists.

B. E. BISHOP, 8654 Winnetka Ave., Canoga Park, Calif., has employees timetables, train order, trade for others; wants Feb. '33 "Railroad Stories," recent issue "Official Guide" and "Ry. Telegrapher."

W. BISSINGER, 3933 56th St., Woodside, L. I., N. Y., wants "Locomotive Cyclopaedia."

WM. BLAIR, JR., 24 Knowles St., Newton Center, Mass., has 9 1/2" x 23" framed builder's photo UP No. 9000 and 8" x 40" of Timken 1111, trade for best offer in revolvers or automatics; write first.

D. E. BLOME, 1112 Spring St., Reading, Pa., has "Official Guides," trade for 116 size, narrow-gauge engines; write first.

R. BRADBURN, 5 Dallas Rd., Torrisholme, Mowcamb, Lancs, England, wants Amer. loco photos.

V. H. BRIDGES, 529 W. Main St., Taylorville, Ill., wants unusual steam, electric, gas-electric power which shows road name and engine No.

E. E. BROWN, Box 228, Stony Creek, Conn., wants PRR passenger locos; has postcard early New Haven locos.

R. BROWN, JR., 665 Dovercourt Rd., Toronto 4, Canada, starting.

A. BRYANT, 14 Sylvan Ave., Royal Oak, Mich., has photos and negs. 30 yrs. back, trade

for Grand Trunk locos 1900-10, esp. 4-4-0, 0-6-0 and 2-6-0.

W. BUTLER, Rm. 905, Municipal Bldg., Brooklyn, N. Y., wants blue print of steam loco.

J. W. CANOTE, 321 S. Griffith St., Hannibal, Mo., has small photos of first U. S. Ry. mail car and Hannibal & St. Joe engine that pulled it, 5c, or 8 x 10 at 75c.

J. T. CHENEY, Box 43, Berkeley, Calif., wants SP power, esp. 4300 class.

F. CLIFFE, 287 W. 4 St., Mansfield, O., wants Colo. Mid., DSP&P employees' or public timetables.

H. L. CLOUGH, Biddeford, Me., wants CPR 2668.

R. COLLINS, 322 Taylor St., N. W. Washington, D. C., wants Lionel Magazines before 1934.

P. CORBIN, Box 74, New Market, Ia., will buy Erie 2-8-4, CPR 3-cyl. 2-10-4, C&O 4-6-2 and B&O 4-4-4.

D. H. CORNISH, 14809 Hilliard Rd., Lakewood, O., has many RR poems to trade for others; give author and title. Has 4 RR cachets, trade or sell.

J. COUTS, 6900 Apple St., Pittsburgh, Pa. has B&O "19," "31," UP, MeC, PRR train orders, trade for photos or others; train order fans, write.

J. C. CRAIG, 9639 109 Ave., Edmonton, Alta., Canada, trades CNR, CPR, GNR, NAR and NPR snaps of buildings and scenes, timetables and train orders for loco photos and copies "Railroad Stories" in good condition.

R. M. CREEL, 5011 Walrond, Kansas City, Mo., will trade Burlington souvenir ticket of Nov. 10, 1934 (first revenue trip of "Zephyr" from K. C. to E. Leavenworth); also postcards of "Zephyr" and schedule.

L. DAVIES, 229 W. 7 St., Mt. Carmel, Pa., starting; send lists. Has detective magazines for back numbers "Railroad Stories."

M. De TURK, 728 N. Front St., Reading, Pa., exchanges Reading snaps for others, esp. short lines, wrecks.

F. R. DIRKES, JR., 50 Robertson Rd., Lynbrook, N. Y., has 116 size of CNJ, DL&W, L&NE, LV, LI, RDG and Joseph Meltzer gas construction engines, trade for same size all roads, esp. SP; has LI snowplow wreck and LI 2-deck coach; wants wreck and builder's originals. Collects RPO post-marks.

L. J. DIXON, JR., 3610 Baring St., Philadelphia, Pa., wants postcard size negs. to be cut down to 3 x 5; has 3 x 5 negs. of PRR, RDG, and B&O. Trades size 116 negs.; has prints of many eastern roads; free list.

R. E. DOUGLAS, Stittsville, Ont., Canada, wants to hear from readers interested in having railroad stationery and envelopes.

V. DREYER, 314 E. 13th St., New Albany, Ind., has 27 timetables different roads, trade for engine photos, esp. large types; B&O Mallets Monon 2-8-2.

R. B. DUNIGAN, 996 Lnk Ave., Springfield, O., will trade six 116 size Big Four or PRR photos for one clear 116 neg.

H. E. EAST, 1704 Main St., Vancouver, Wash., wants Milwaukee, Burlington, D&RGW, WP, GN, Santa Fe and Erie 5018; has NP, M-K-T, SP&S, SP, NWP, GN, UP and "Royal Scot," also U. S. and Br. Colonies stamps.

B. EDWARDS, 9635 109 Ave., Edmonton, Alta., Canada, will trade one CNR rule book, one CPR general train and interlocking rules for engine photos.

W. A. EELMAN, R. D. 3 Manchester Ave., P. O. Paterson, N. J., has 6 Lionel Magazines to sell or trade for Erie or DL&W snaps.



P. EILENBERGER, 380 E. 11 St., Chicago, Ill., has new NP 4-8-4 and NKP 2-8-4; 10c for sample and list of 50 roads.

E. A. ELLIS, Dryden, Me., wants 116 size neg. of Portland Term. No. 324 before rebuilt; have McC, CNR, B&M engines and equipment to trade.

L. C. EYERLY, 39 Helen St., Binghamton, N. Y., sells 8 x 10 size, Greytone finish, photos DL&W No. 1632 (4-8-4) 25c postpaid.

J. H. FARMER, 490 E. Water St., Lincoln, N. C., has "Railroad Stories" 1929-33 to sell or trade for B.R.T. magazines or emp. time cards, NC&Va. Div. of SAL, Charlotte Div. of Southern Ry.; also small road public timetables. Trades wreck clippings; write.

W. B. FLETCHER, Ironton, Mo., has "Wreck of the 97" photos showing the engine, cars, trestle, 8 x 10 size at \$1; 5 x 7", 75c postpaid.

W. FOELS, Blackstone, Ill., wants narrow-gauge short lines and amusement RR pictures.

G. E. FOSTER, 129 Farnsworth Ave., Borden-town, N. J., will sell 17 x 22 photo Rosendale Bridge, Walkill Valley Ry. showing bridge and train.

J. K. FRENCH, 456 Pine Ave. W., Montreal, Canada, has 60 prints modern power in Montreal, trade for English locos; send list for list.

I. GEORGE, 2 Middagh St., Brooklyn, N. Y., has 8 x 10 (enlargements) builders' photos of Colorado Midland Nos. 53, 306, 201, 29, at 20c ea.; 3 for 50c, postpaid; makes 8 x 10 enlargements from any neg. up to 4 x 5 at 20c ea.; 3 for 50c, 7 for \$1, postpaid.

F. K. GILE, 4675 Tibbett Ave., N. Y. City, has NYC electric, Rock Island train, C&S narrow gage, and D&RGW No. 1; 10c. ea.

AL. GIROUD, 19 Rue Lamande, Paris 17, France, will pay \$2 ea. for NYC calendars 1922-25 inclusive.

W. C. GLASS, 852 Ashland Ave., N. E., Atlanta, Ga., wants Oct. '30; June Sept. Oct. Nov. '31; Jan. Feb. Apr. May June '32 "Railroad Stories," 20c. ea. plus postage. Write first.

J. A. GROW, 752 N. Liberty St., Rushville, Ill., will trade Burlington "Instructions to Agents & Conductors, 1900" or blueprint of old Portal Interlocking plant at Galesburg for "Official Guide" of about 1900; also trades Wabash employees' time cards, train orders, 116 size snaps of mid-western, western and World's Fair engines for engines only. Best photo offer takes enginemen's register of Colo. Springs & Cripple Creek Dist. Ry. from Nov. '06 to May '07.

R. M. HANFT, Brainerd, Minn., wants back copies "Railroad Stories"; Sept. '34; Aug. Sept. '33; Nov. '33 through June '34; issues previous to Nov. '32; write first.

C. T. HESS, 7814 Westwood Dr., Chicago, Ill., has Milwaukee engines to be junked and C&NW power; collects old or new timetables.

C. HESSELTINE, Gen. Del., Centerville, Iowa, trades engine photos for any U. S. or Canadian speed pictures. Best offer takes copy of T. W. Jackson's "On a Slow Train Through Arkansas."

F. J. HEURICH, 2583 Hackney St., Pittsburgh, Pa., trades Pittsburgh street car transfers for others.

A. HOOPER, 203 Matte St., Meaderville, Butte, Mont., wants formula for solution for preventing newspaper clippings from turning yellow.

H. HUDSON, 260 W. 2nd St., Fulton, N. Y., buys loco and RR equipment photos, esp. DL&W.

D. B. HORNER, 1455 5th Ave., Freedom, Pa., wants PM and C&S rosters; has other rosters to trade.

F. IIVSON, Gen. Del., Trail, B. C., Canada, will buy GN 2-8-8-2 type; has 42 cigaret size colored pictures of engines of the world, sell or trade for photos; write first.

S. G. JENSEN, Box 564, Green River, Wyo., will trade photo of UP 1840 with crew which pulled Roosevelt's special in 1903, for photo of W. J. Atkinson, chief clerk to M.M. D.E. Sullivan at Green River in 1898.

P. JOHNSON, R. 3, Box 220, Mt. Vernon, Wash., has Nov. '31, Dec. '31 and Aug.-Nov. '33, "Railroad Stories," at 15c ea. prepaid.

H. E. JOHNSTON, Box 82, Scotch Plains, N. J., wants old N. J. steam photos; also old trolleys of N. J., Pa. and N. Y., esp. Public Service abandoned divs. Has several dozen traction lines.

K. M. KIER, 2312 W. 107th Pl., Chicago, Ill., buys wreck, washout photos, esp. LV wreck on p. 34, Sept. '34.

P. W. KLINE, 422 Windsor St., Reading, Pa., sells postcard of Reading and Pa. roads at 7c. ea.; one photo free with every order of 4, good until Mar. 15, only.

J. KROLL, Gen. Del., Reedsburg, Wis., has 46 unmutated back copies "Railroad Stories"; Dec. '29-Jan. '33, Mar. Apr. '33, May '34-Oct. '34 inclu.; also 30 different timetables; enclose postage or reply card.

W. C. KROLL, 144 Lincoln Ave., Newark, N. J., will sell collection of 600 tickets, inclu. interline, local, mileage, commutation, special rate.

H. F. LAMPRECHT, 2091 W. Broad St., Columbus, O., collects, exchanges street car, bus transfers.

L. LANSING, Box 296, Salisbury, Conn., wants timetables of CNE, H&CW, P&E, PR&NE.

E. M. LEO, 2451 Catherine Rd., Pasadena, Calif., has 500 photos, (127, 120, 116 size) Santa Fe, SP, UP; trade for others.

LOCOMOTIVE PHOTOGRAPH CO., Box 6354 W. Market St. Sta., Philadelphia, Pa., will give free 4 x 5 photo of new Reading streamline with each \$1 order. Until April 1st.

LOCOMOTIVE PUBLISHING CO., 3, Amen Corner, London, E. C. 4, England, has colored plates (8 1/2 x 20) of LNER new 2-8-2 type, 1 shilling; J. F. Byrne, E. McKeesport, Pa., is American agent, has them at 40c ea. incl. duty.

L. LINTON, Pryor, Okla., will pay good price for Jan. '32 "Railroad Stories."

T. V. MAGUIRE, 1712 Douglas St., Rockford, Ill., wants Milwaukee Nos. 2239, 2235-2337, 2340, 2713, 2715, 2717, buy or trade.

W. A. MASSEY, 146 Hampden St., W. Springfield, Mass., will buy 1931 "Car Builders' Cyclopeda," good condition or trade for LaSalle course Higher Accountancy or Amer. School course in Architectural Drafting.

A. MATTINGLY, Stittsville, Ont., has 116 size small Canadian construction and logging roads, also CPR and CNR; list and sample 10c. Wants 116 size D&H, UP 4-12-2, PRR and NYC electrics, 4-4-0 and Mallet types any road, streamlined trains.

C. F. McBRIDE, JR., Digby, N. S. has 116 size of DARY., ships, steamers; trade for engine photos.

W. S. McCABE, 807 Evans Ave., Akron, O., wants B&O No. 1649; also wishes to hear from old ralls.

P. A. McMILLAN, 7055 N. E. Flanders St., Portland, Ore., has 116 size SP on Portland Div. sale or trade; write for list and sample.

R. E. McMULLEN, 574 Park Ave., Galion, O., will sell to highest bidder: Harding's funeral train; 6 Erie (1908) wreck photos at Galion; many western train orders; 4 scrapbooks, over 1000 clippings and photos; good photo of D&H wreck in 1922.

E. T. MEAD, North St., Greenwich, Conn., wants: PRR 2-10-0; engine on Pikes Peak; Live Oak, Perry & Gulf; Shay 10-wheeler; New Haven 4-6-2.

MICHIGAN RAILROADS' ASSOCIATION, R. H. Allie, Publicity Director, 318 M. C. Term., Detroit, Mich., wants to hear from Michigan fans.

MIDAS CAMERA-PROJECTOR CO., 10 W. 33 St., N. Y. City, will send free booklet describing combination moving picture camera-projector run by self-contained battery to anyone writing.

F. MILLER, JR., 1342 10th Ave., Schenectady, N. Y., sells 1934 timetables.

L. MOLONEY, 6026 Nickerson Ave., Norwood Park, Chicago, Ill., starting collection; wants any photos.

L. W. MOODY, Union, Me., wants photos, data of 24", 60 c.c., etc. gage roads, esp. in N. Amer.

R. J. MOYLAN, Hotel Moylan, W. Liberty,

Iowa, interested in anything about Colo. Midland—photos, train orders, passes, timetables, etc. Send lists.

L. W. NELSON, Lanham, Md., will buy or trade for 5 x 7 or 116 size early Minn. or S. Dak. locos.

N. NELSON, Box 161, Pontiac, R. I., wants side view NYC "20th Century" engine; has 3 colored side views. NYC trains and one PRR, at full speed.

S. NEWCOMBE, Bridgetown, N. S., Canada, collects engine, wreck photos.

NATIONAL ASSOCIATION OF R.R. ENTHUSIASTS announces its N. Y. Division, embracing N. Y., N. J., and Pa. All residing therein who are interested, write to A. P. Formanek, 1868 Holland Ave., Bronx, N. Y. City.

R. NEWNES, Salmon Arm, B. C., Canada, has *Loco. Engineers Journal*: July-Sept. '28; Mar.-May '29; Mar. May, July, Aug. '31; Jan.-July '33; trade for CPR Mallets, 4-4-2, 4-4-0, old 4-6-2 in 1100 class with Stephenson valve gear, modern 4-6-2 in 2500 Class; also NYC 4-6-4.

WM. PATZER, Box 15, Secaucus, N. J. has "Railroad Stories" July '33 to date; what offer?

J. E. PLATT, 97 Inchbury St., Hamilton, Ont., Canada, has many CNR and old TH&B to trade; wants B&M and B&O.

A. PLAYFAIR, 4568 Draper Ave., N. D. G., Montreal, Canada, collects CNR engine snaps.

C. POMISEL, 762 Hegney Pl., Bronx, N. Y., collects timetables, clippings, engine and wreck photos; has 5 scrapbooks dating from 1917.

J. M. PROPHECT, 3rd, 142 Main St., Mount Morris, N. Y., wants good PRR photos, postcard or larger; has many 27/8 x 47/8" for sale or trade. Will give specifications and answer questions on PRR locos for 3c. stamp.

R. PHELPS, 1319 24th St., Ogden, Utah, has lost address of Miami fan who sent timetable to his old address.

C. F. REIGN, 201 E. Fort Ave., Baltimore, Md., has 1000 foreign engine clippings, sell 4 for 1c. or trade 30 for Baldwin builder's photo.

R. W. RICHARD, 247 Grant St., Cape May, N. J., trades or buys PRR engine photos, time cards, tickets, etc.

A. RICHARDSON, 5 Langley Tower, 25 Langley Road, Surbiton, Surrey, England, wants to hear from readers anywhere.

J. RICHMOND, North Bend, B. C., Canada, will get photos of CPR motive power on order.

H. RIGOR, 812 Main St., Elwood, Ind., has PRR and NKP, sell or trade; send 10c. in coin for list and sample.

E. G. RIOUX, 80 Farrington St., N. Quincy, Mass., has "Distinctive American Trains," New Haven 1934 timetables, employees' magazines, "RR Trainman," and B&A Rule book, trade for photos; also trades photos.

E. ROBERT, 3903 S. Tyler, Tacoma, Wash., has photos of Milwaukee engines now being scrapped at Tacoma; photos other northwestern roads; 6c. ea., 20 for \$1.

W. ROBERTS, 1320 N. Main St., Salisbury, N. C., wants to hear from U. S. and foreign fans.

W. W. ROBINSON, Box 31, Batavia, N. Y., has old public timetables BR&P, Tonawanda Vv., TV&Cuba; trade for old timetables and photos, eastern short lines.

R. ROEDEMA, 58 N. 14th St., Hawthorne, N. J., sells postcard engine snaps cheap, gives free 10" colored enlargements of NYC "20th Century Ltd." Write for particulars; glad to aid beginners.

H. J. ROSENKRANZ, 36 Warren St., Bloomfield, N. J., buys 116 size prints all U. S. and Canadian roads; esp. Wharton & Northern and Erie; send lists.

R. K. SAWYER, 43 Marshall St., Somerville, Mass., has 5 1/2 x 2 1/2 B&M roundhouse at E. Cambridge (now abandoned); wants B&M train orders.

F. SCHOERNER, Arminto, Wyo., wants photos of circus show trains, wagons, etc.

H. R. SELOOVER, RFD 2, Amboy, Ill., has hundreds public and employees' timetables, other RR and engine literature; sell cheap; stamp for list.

E. SHERMAN, Box 75, Deerfield, Mass.,

wants to hear from anyone making engine drawings.

E. R. SILBER, Box 154, Pequannock, N. J., wants old and new loco photos.

C. SIMON, R. 2, Box 43, Farley, Ia., wants Uintah Ry., CGW 2-6-2, IC 7000 and following "Railroad Stories": July, Aug., Dec. '32; Mar. '33.

W. R. SNOWDEN, Box 576, Kamloops, B. C., Canada, has CPR, CNR engines at Kamloops. L. E. STAGNER, JR., 803 W. McKinley, Blackwell, Okla., wants Frisco 2-8-2.

H. G. STEINMEYER, 174 Nixon Ave., Tompkinsville, Staten Island, N. Y., wants postcard of Erie, PRR, B&O; sells or trades postcard of ERIE, PRR, B&M, CNJ, NYC, others.

G. STRECKERT, Chilton, Wis., will pay 10c. ea. for 116 size negs. U. S. and Canadian roads; send list and sample neg.

E. E. STROCK, 590 State St., Conneaut, O., trades NKP at least postcard size; has negs. all classes; 6 1/2 x 8 1/2, 25c.; 5 x 7, 15c.

J. S. TANTER, 16 Shaw's Court, E. Lynn, Mass., draws any type steam locomotive in color or black and white; has 6 different views of BRB&L "No. 14," abandoned.

F. THACKRAH, 86 Fairview Pl., Amsterdam, N. Y., buys UP, NYC, CB&Q since 1924; send prices.

D. W. THICKENS, RFD Box 196, Walnut Creek, Calif., has 116 and postcard size of San Joaquin & Eastern; Sierra Ry., Fresno Traction and Petaluma & Santa Rosa freight motors.

(MISS) M. TRUELOVE, Peninsula Sta., c/o Breakers Hotel, Daytona Beach, Fla., starting; needs help.

W. C. TURRILL, R. 2, Belpre, O., wants postcard NYC 5322.

D. TWOMEY, 5 Maine Ter., Somerville, Mass., will buy Ives catalogs; first state price.

F. T. VAN BUSKIRK, 562 Hollibaugh Ave., Akron, O., will sell complete set "The Science of Railways," by M. M. Kirkman, 12 vols., 1896, to highest bidder.

R. WACKER, 89 Hickory St., Islip, N. Y., will trade timetables, copies of "RR Data" and "UP Bulletins" for "Railroad Stories," Feb.-Sept. '33.

R. B. WALKER, Blue River, B. C., Canada, lends one negative for another; trades or sells Canadian roads, incl. wrecks.

H. E. WEISS, 1144 N. Spaulding Ave., Chicago, Ill., has Milwaukee Rd. to sell or trade for other Milwaukee engines or equipment, esp. Class D-1., or M&StL power; will take photos on order for Chicago roads.

F. W. WEINGETZ, JR., 8761-118th St., Richmond Hill, N. Y., has closeup side view of pilot and driving wheels PRR No. 305; 124 size, 10c. ea. or 3 for 25c.; 5 x 7, 50c. or 3 for \$1.25, postpaid; will buy, trade or sell all types photos, clippings, books, calendars, stamps and Lionel "O" or Standard gage equipment.

R. S. WENDELING, 53 Menzel Ave., Maplewood, N. J., buys JC Traction Co., Morris Cty. Trac. Co., and NJ Interurban trolley photos.

J. WHITAKER, 710 Jackson St., Bakersfield, Calif., wants any issue "Baldwin Locomotives"; "Railroad Man's" prior to 1919; write, give price. Nearby fans, write.

G. T. WILBUR, 39 12th St., New London, Conn., wants photos of following Conn. Co. trolleys destroyed at Thamesville: 133, 134, 162, 165, 167, 169, 365, 366, 369, 372, 768, 0315, 0323, 0329, 1275-77, 2227, 2281, 2302, 2308.

(MISS) H. WILLIAMS, 22 Dunbar St., Uniontown, Pa., starting; grateful for any photos.

R. O. YERGER, 537 Queen St., Northumberland, Pa., has following "Railroad Stories": Jan. '30, Apr., May '31 at 30c. ea.; Mar.-Dec. '32 for \$2.20; Jan.-Dec. '33 at \$2.64; Jan. to Dec. '34, \$2.64-\$7.50 takes the lot, postpaid.

#### Proposed Abandonments

Central R. R. of N. J., Nolan's Pt. to Ogden Mine, 10 miles. Pacific Coast R. R., 12 miles of branch lines (abandonment authorized). Tennessee & Carolina Southern, Maryville to Calderwood, Tenn., 31 miles. Chicago & North Western, What Cheer to Consol, Ia., 55 miles. Elgin, Joliet & Eastern, S. Wilmington to Goose Lake, Ill., 12 miles. North & South, Salt Creek to Ilco, Wyo., 41 miles.

# TRUE TALES OF THE RAILS

Actual Happenings Told by Eye Witnesses

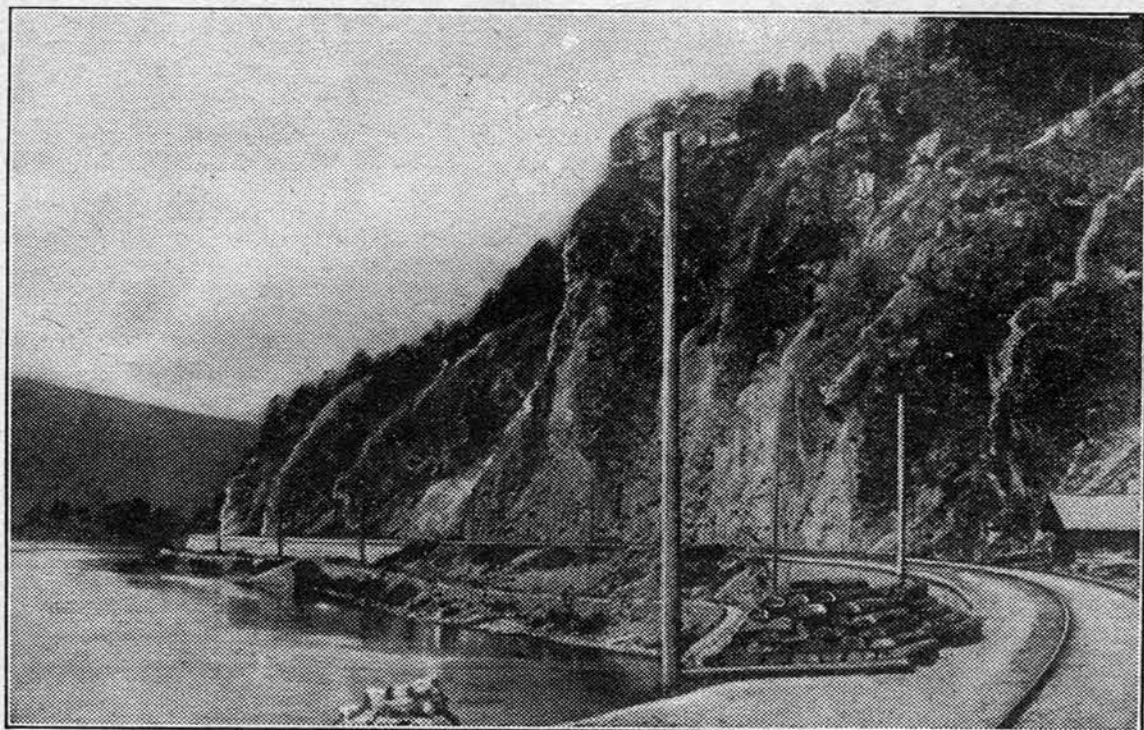

The Main Line of the Trans-Siberian Railroad, Where It Swings around the Southern End of Baikal, the World's Deepest Lake. See Map on Pages 50 and 51

## Red Rails

By NEILL JAMES

**H**ONOLULU to Moscow—job hunting. My friends said it was a crazy idea. When I arrived in Moscow and found there were jobs galore, with salaries for office workers ranging from 100 to 500 rubles a month, I was jubilant. When I discovered these ruble salaries were equal in buying power to \$2.50 to \$12.50 in American money, I departed. But the trip to Moscow from the East was fascinating.

Information about rail travel in Communist Siberia was meagre. I bought a ticket anyway, to Moscow via Manchuria and Siberia. Russia is a classless nation, and so the various price levels for railway travel are called categories. About the only differences between first and second are a wash basin (which first has and second has not) and the price which is \$50 more for first. The cost of the eleven-day, 6,000-mile, train journey from Dairen to Moscow, second cate-

gory, was \$135.00. It is now considerably higher.

I sailed from Shanghai on a small Japanese steamer, down the Whangpoo River and up the China coast to Dairen, where I transferred to the South Manchuria Railway, owned and operated by the Japanese Government.

Traffic on the train out of Dairen was heavy. Coaches were literally stuffed with passengers and baggage. All available racks were overhanging with personal luggage, corridors were blocked, and even the joint washroom for men and women contained surplus hand bags. There was no provision made for free transportation of heavy personal baggage, and the passengers crowded the cars with hand luggage.

I found myself sharing a small compartment with two Russians and a Japanese — all men, plus nine hand bags and suitcases. The situation seemed impossible. Armed with a ten-yen note, I hunted up the Japanese conductor.

"Please, can you give me a separate compartment. *Taksan danna-san*," I said, adding a couple of words of Japanese I knew to make him understand there were too many men. I fingered the banknote.

He looked at it. "I am very sorry for you, madam, but there is not a vacant compartment," he replied in perfect English, bowing politely.

"Then please change me to a compartment with women in it," I pleaded.

"*Oku-san arimasen*," said he, bowing again. "There are no women."

The situation was bad, but not as bad as it could be, I was shortly to discover. A young Russian visited a compatriot in my compartment. Upon learning that he had no place to sit or sleep, he was promptly invited to share half a berth in my compartment. So we slept five in this small four-berth compartment: three Russian men, a Japanese, and one American girl. The window was tightly closed and the door locked.

One luxury I did not properly appreciate at the time was that my berth had the privacy of a curtain. This was the only train on this eventful trans-Asia trip where I was to enjoy such luxury.

Immediately after breakfast the next morning we arrived in Changchun, or Hsinking as the Japanese have now renamed this Chinese city, a lonesome little town squatting in the midst of a broad expanse of well tilled plains.

The traveler in Asia who must change trains has to be alert, because throughout Manchuria and Siberia there is a passion for changing names of age-old towns. In Manchuria the Chinese names are not liked by



MISS NEILL JAMES  
Author of "Red Rails"

the Japanese, so they have changed the names of important towns. In Siberia the most important of the old Tsarist towns dating from the sixteenth century have been renamed by the present Communist rulers.



When the 900-Mile Turk-Sib (Turkestan Branch Line of the Trans-Siberian) Was Completed a Few Years Ago, Natives for Miles Around Came to the Celebration

I WAS alarmed to read an account of the deliberate wreckage of this train by bandits, who robbed the passengers, took many prisoners and held them for ransom. I had heard of an old Chinese custom that prescribes the pouring of liquid cement into the ears of too alert captives in order that they cannot hear what concerns them very much.

The Chinese Eastern Railway cuts a Russian pathway across the whole of North Manchuria. It is along this railway that bandits are most active. Chinese farmers have been forbidden to plant kaoling, a tall grain, within a half mile of the right-of-way, as it affords excellent ambush for roving bandits who periodically wreck and plunder trains on this line.

The passenger train on the run from

Harbin to Manchouli, the last Manchurian outpost before entering Russian territory, carries an armed guard of thirty or more Japanese soldiers. A dozen or more soldiers with fixed bayonets picket the train as it stands in the station, a precaution against a sudden raid of bandits. The schedule is so arranged that the train makes the most dangerous part of the journey during daylight hours.

Near the town of Hailar, with its typical Chinese architecture, the railroad crosses the Great Khingan Range. At the pass it goes through a tunnel nearly two miles long, over the western arch of which is a Russian inscription "To the Pacific Ocean." True, it is more than a thousand miles to the ocean, but the pass leads there.

The Chinese Eastern connects with



This Dashing Old Gent, Believe It or Not, Doesn't Live In Hollywood, but Was Snapped While on His Way to Catch the Trans-Siberian Express

the Trans-Siberian line at Manchouli. Two trains a week are run across Siberia, the "De Luxe" train leaving on Mondays and the Trans-Siberian Express on Thursdays. The De Luxe and the Express make the trip in exactly the same time, and the fare is the same, but the former caters especially to foreigners and carries an English, French, German and Russian speaking staff. It also has a shower bath, which the Express does not have. Neither hauls an observation car.

The 10,000-kilometer (6,212 miles) journey from Vladivostok to Leningrad, more than twice the distance

from New York to San Francisco, is made by both trains in eleven days.

This is the main line of the world's longest single system. The slender steel thread of the Trans-Siberian line, which stretches across the broad expanse of Asia and joins the European Russia system, took twenty years to build, cost the staggering sum of one thousand million rubles (\$500,000,000 at the time), and opened up one of the richest territories on the earth's surface.

It stretches 3,000 miles across Siberian steppes, from the Ural Mountains to Irkutsk, without a tunnel; then suddenly in the Lake Baikal region the train speeds through 39 tunnels, the largest a half mile long.

The Lake Baikal section presented the most difficulties to the engineers who built the road. While the problem of getting through and around the mountain range that circles Lake Baikal was being solved, a forty-mile, 250,000-ruble floating railroad was built across the ice on Lake Baikal, the world's deepest lake.

Tree lengths of light pine were used as sleepers, some being 50 to 60 feet long, which gave the railway an awkward appearance, but it served the purpose. Snow was tamped around and under the rails, and when it packed down, forming ice, the railway was not only on the ice but firmly imbedded in

it. When spring thaws came, the huge sleepers floated and held the rails above water, although trains could not be run across the lake until it froze again.

The line around the lake, which now winds in and out and through and over the spurs of the Altai Mountains, was five years in the building. Lack of double-tracking and this unfinished section proved a great handicap to Russia during her war with Japan early in the century, but the Soviets are rapidly overcoming this handicap, and soon the double-tracking of the entire Trans-Siberian line will be completed.

**W**E had a six-hour wait in Manchouli for the Russian train, and in the meantime the eastbound De Luxe arrived from Moscow. I talked with two American business men who got off the train. As we stood on the platform enjoying the warm spring sun, a railway official approached us.

"The trunk, it is yours?" he said to the tall American.

"Yes, the trunk, it is mine, why?" he mocked the collector.

To his companion he said, "Bet you five bucks he wants more money."

The official fumbled with a mass of papers. "You go to Harbin, yes?"

"Yes," replied the American.

"Ah, then you must pay ten dollars for the trunk."

"All right, brother. That damn trunk has already cost me a fortune,

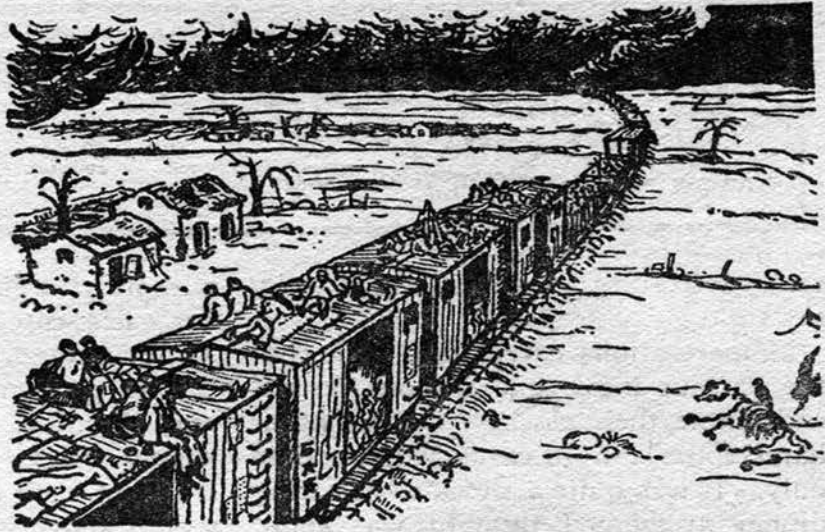

From "Pageant of Chinese History," by E. Seeger; Longmans, Green & Co., N. Y. City

When Famine Comes to Manchuria

so what's ten dollars more," he said, peeling a ten spot from a roll of bills.

"It must weigh at least a ton," I observed.

"Oh, yeah? It weighs less than two hundred pounds. They make you pay through the nose for every pound." He got out a note book and did some rapid calculation. "Look here, Burt, by the time we reach Shanghai this trunk will be worth its weight in gold. It will have cost me a hundred and fifty-five dollars to bring it from London."

**A**N engineer whose watch is always on the dot would go mad chasing the time on a Siberian train. Although there is a difference of seven hours between Moscow and Vladivostok, the train carries Moscow time, and the faces of the clocks carry numerals from 1 to 24. My train arrived in Manchouli at 7.10 A.M. local time, and was scheduled to depart the same morning at 6 A.M. Moscow time, which was 12 noon local time. It was an hour and a half late getting started, and so it



really left at 13.30, which was 1.30 by my time.

Some stations carry local time, but the various local time stations do not coördinate their clocks. On the other hand, some stations carry Moscow time only. It was quite a shock to be eating dinner at what I thought was about 6 P.M., and then glance out the window at the station clock and find it past midnight, though the sun was still shining brightly. Again, some stations have a large clock at each end of the platform, one with local time and the other Moscow time.

The Trans-Siberian railway is as far north as Labrador. In this latitude, in summertime, it is dark only about three hours out of the twenty-four. Therefore the sun was not much help to a confused passenger. Finally I abandoned the struggle, let my watch run down, and ate when I got hungry.

When we left Manchouli and entered Siberia, we left the railway guard at the border. Apparently the Russians had not the Japanese fear of bandits.

I had just settled myself in a two-berth second category compartment with an Englishwoman as a traveling companion, when the "car-comrade" (he was the porter, but no one called him that) appeared with steaming glasses of hot tea or *tchai* as it is called in Russian. He presided over a samovar in the first-category end of our car, and assisted by the comrade in the second-category end, they served hot *tchai* throughout the journey,

without charge. This luxury was only for first-category passengers and second category in the upper brackets.

The government provides for one and all alike, without cost, an ample supply of *kipyahtok*, or boiling hot water at each station. The faucet has a sign above it in large letters, and as soon as the train stops at a station, passengers seize tea pots and there is a wild dash for *kipyahtok*. Another scramble ensues when, having ignored the all aboard signal and the whistle, the train actually begins to move, and several passengers with kettles of boiling water try to make the high steps of the cars.

The tall, blue-eyed car-comrade with unusual red hair, who spoke German and Russian but no English, in addition to having charge of the samovar, took care of the compartments, swept, dusted, wiped the polished woodwork of the corridor, and kept all windows securely shut. As a side line, he carried on a secret, illegal business, which will entitle him to a long residence in Siberia when and if he is discovered.

There is a great scarcity of sweets in Siberia, and the car-comrade was a sugar-bootlegger. He was doing a great favor to these sugar-starved pioneers, and incidentally making a profit for himself.

At stations, Siberiaks rushed in, whispered *saxar*, having the rubles ready, exact change. The comrade looked around, making sure they were unobserved, opened a secret panel, gave



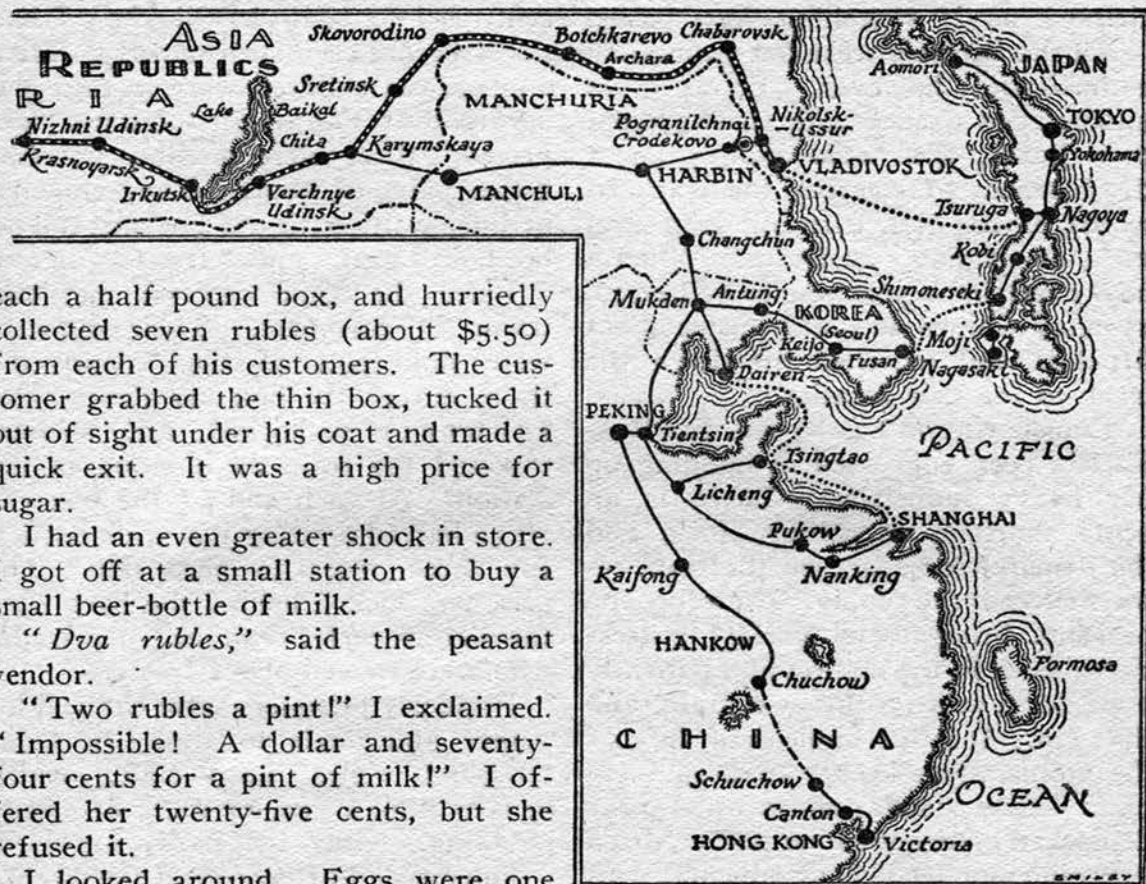

From Passenger Timetable, Intourist,  
261 5th Ave., N. Y. City

The World's Longest Distance Through  
Train Travels over This Route, Averaging  
24 Miles an Hour for More Than 6000 Miles

each a half pound box, and hurriedly collected seven rubles (about \$5.50) from each of his customers. The customer grabbed the thin box, tucked it out of sight under his coat and made a quick exit. It was a high price for sugar.

I had an even greater shock in store. I got off at a small station to buy a small beer-bottle of milk.

"Dva rubles," said the peasant vendor.

"Two rubles a pint!" I exclaimed. "Impossible! A dollar and seventy-four cents for a pint of milk!" I offered her twenty-five cents, but she refused it.

I looked around. Eggs were one ruble each, butter six rubles a pound, black bread one ruble a loaf, and a roast chicken sold for fifteen rubles. I was about to peel and eat an orange. I changed my mind, and offered it to the peasant, who willingly traded the pint of milk for it.

**A**LTHOUGH we kept the same two comrades on our car, now and then we changed trainmen. "Trainmen" is hardly the word, for often we drew a pretty girl to mind the rear end of the train. Her uniform was a dark cotton skirt, uniform woolen coat and visored cap, which she often discarded for a bright kerchief wound attractively about her head. Whenever the steaming samovar in the front end of the car ceased to steam and there was no one to serve hot *tchai*, I knew

where to find the red-headed comrade. Invariably he'd be on the rear platform entertaining the rear brakeman.

Although railroading in Siberia is certainly a man-sized job, many women are engaged in the profession. Large section crews of women engaged in loading and unloading handcars. When transporting a loaded handcar, as many women as could cluster about pushed it, while the forewoman marched well ahead, carrying a staff with an insigne on it, which she planted in the middle of the track when they stopped to unload. They put real zest in their labor, and when the handcar was well under way, they threw back their heads and

chanted as if marching into battle.

All the workers were not young and enthusiastic, however. Some were middle-aged women with shawls about their heads, who went stolidly about the business of clearing the track of weeds, laying ties, carrying long steel rails, or spading out drains. When a heavy telephone post was to be moved, as many women as could cluster about lifted it and marched off down the track to the new location.

Transportation has lagged, for Russia has been engrossed in building up her heavy industries. There is an acute shortage of rolling stock, and the demand for space on the train always exceeds the supply. Therefore the peasants bring their worldly possessions, sleep in the station and patiently hope for a seat on the next train, and the next. It is the unpleasant duty of the woman gate-keeper to keep them back. She stands sentinel-like near the locked gate, key in her pocket, often engaging in heated arguments with would-be passengers.

To the traveler who crosses Siberia in spring, it is a rich agricultural land of limitless green plains and beautiful flowers. But to countless thousands unhappy Russians, Siberia is still Siberia, a land of living death. In Mid-Siberia the Express stopped for half an hour at a station at which an emigrant train stood. The long train was composed of ordinary box cars stuffed with men, women and children, thirty or forty being crowded into each freight car where they lived. The floor of the car was covered with straw.

A Russian engineer explained to me they were "deprived" people, that is, people who were unsympathetic with the present régime, or peasants who refused to turn over their little farms to the Government. For this they were

sentenced to labor in Siberia. I had never before seen such poverty. Men, women and children were in rags and barefooted. Out of the thousand "deprived," there were possibly not two dozen pairs of boots. They shivered in line, waiting to get buckets full of hot boiled grain with a few fish on top.

Later the same day we met two trains of prisoners. Their quarters were duplicates of the "deprived" train, except the box car doors were securely padlocked, and soldiers picketed the train as it stood in the station. At each end of the box car was a barred opening just wide enough for three faces to peep out. The prisoners locked behind the bars were far more cheerful than the "deprived," who were moved about freely.

Formerly prisoners were chained together and made to walk the three thousand miles into exile, which usually took a year or more of steady plodding. Only the hardy survived.

During mid-afternoon of the day we were to arrive in Moscow, my destination, there was great activity aboard. Passengers were shushed into corridors while compartments were whisked and dusted. At one station just before reaching Moscow squads of scrub women swarmed aboard and mopped the floors and wiped the woodwork. Other squads of women armed with ladders and buckets assaulted the outside of the train. Windows were washed and polished. Men and women busied themselves oiling, inspecting brakes and looking for hot boxes.

A clean linen hand towel and a bar of soap were placed in the lavatories—luxuries we had not enjoyed before on the trip. The comrades slicked themselves up, and we made an impressive entrance into Moscow, just twenty minutes late.

# Beef Tallow and Limburger

By "HIGHBALL JOHN" BURNS



**I**N bygone days, before cylinder or valve oil came into general use with the lubricator, beef tallow was used to oil valves and cylinders on wood-burning engines.

I first noticed its use in the year 1886. Tallow came to the roundhouse oil-room in large oak barrels. In zero weather we had to chop it out with an ax. The store-room clerk would knock in the barrel head. If the tallow was fresh he would keep it in the oil-room and weigh it out to the "tallowpots" (firemen) as they called for it.

But in hot weather when the tallow was good and ripe, with the barrel full of fat wigglers which gave off a most offensive odor, the clerk would roll it outdoors and invite us to help ourselves.

"Take all you can use," he would say, "for you certainly won't get any more until that barrel is empty."

So Mr. Engineer and Mr. Tallowpot would have to hang a clothes-pin on the end of their noses every time they gave the old wood-burner's valves and cylinders a shot of that over-ripe tallow through the tallow cups. However, it was great stuff to start a fire, and many a pound of spoiled tallow went into the firebox.

My old friend Rube Shosser, hogger on a yard goat, for whom I fired more than forty years ago, liked a can of beer with his lunch. Often this lunch consisted of limburger cheese sandwiches of rye bread, which he brought from home in a paper bag and stored in his seatbox.

The night engineer, Baldy Taylor, kept clothes in the same seatbox, along with a tobacco sack full of asafetida, which he claimed acted as a disinfectant. When Baldy got home each morning his wife would not give him breakfast until he took a bath and changed his clothes. She maintained he had been sleeping in a stock car with a bunch of dead hogs.

Finally Mrs. Taylor's protests became so vehement that Rube had to keep his limburger cheese in the toolbox. Rube's regular fireboy was up to the limburger racket and would stick his head out of the cab window for fresh air. One day the regular fireboy laid off and Rube drew a green kid to fire his engine. While the hogger was washing down his limburger and rye with a can of beer, the new fireboy sang out: "Hey, Rube, we musta got another can of that damn rotten tallow again!"

**S**PEAKING of unpleasant odors reminds me of the bright summer morning about thirty years ago when Engineer Jimmy Gleason and I brought a live skunk to Chicago on the pilot of his pet ten-wheeler. Jimmy Gleason wasn't his real name, any more than Rube Shosser was the other hogger's name, but the facts are all true.

Jimmy had the "milk shake" run, a six-car mixed train that stopped at every country station and crossroads to pick up milk cans and occasionally a crate of chickens. I was firing at the time we saw the white-striped pussycat on front of the engine. We cussed it,

closed the cab windows and headed for town.

Into Grand Central Depot we rolled and made an impressive stop right beside an outbound Baltimore & Ohio limited. Cooks and waiters quickly closed the windows and made menacing gestures at us.

We had forgotten about the skunk, and wondered what was wrong. Jimmy dropped down to the depot platform to give his high-wheeler the once-over, to see if she had brought all her drivers and the side-rods to town with her. There he found the ill-smelling animal sitting pretty on the pilot crossbeams, his head sticking out between the beams.

Disgusted, Jimmy grabbed up a handful of track ballast and threw it at the creature. This hurt Mr. Skunk's

feelings so badly that he turned on the fireworks and perfumed things proper. Then he scrambled out from under the pilot and made a bee line for the B. & O. dining car, where he parked himself on a car truck. The station master, coming on the scene, gave the hogger "Hail Columbia."

Jimmy promptly disclaimed ownership of the skunk. "If the B. & O. boys want him and feel like making a pet out of him," said Jimmy magnanimously, "why, that's all right with me."

With that he climbed back on the ten-wheeler and rang his bell, and the hostler backed our engine out of the depot trainshed. We never learned what the B. & O. boys finally did about that skunk. If any old-timer who remembers how this incident ended, I wish he would tell me about it.

## The Boomer Trail



OUR stories about boomers out West, with trains going down somebody's mountain 90 m.p.h. and only one good brake to hold 60 cars, are sump'n. What the hell, brothers; that doesn't happen any more on anybody's pike. And

that hero of the throttle stuff. I ask you, gentlemen, did you ever see a hero of the throttle? I know a lot of throttle jerkers here and there around the country, but none were heroes.

Anyway, I started out to be one of these heroes, but the brass hats put up a job on me, for every time I looked for a job firing, I always landed one as a shack. And so I never got my name in the newspapers by having a couple of nice wrecks, etc. Nobody ever hears of a conductor or brakeman having thrills and adventures; they only sit in the doghouse and spell out the words of old newspapers.

All the boomers aren't out West, either. There are plenty of 'em right in New York City, Philadelphia, Baltimore, or almost any old place. Stand on Sands St. in Brooklyn some nice evening or Sunday, and you will see men who were real boomers from 1900 to 1920. Jeff, Red, and Highball W.—all are there around the white-tiled eating house under the elevated.

Go up to 176th St., on the Lexington Subway. But it's elevated up there, so go down the steps, cross the street, look in a "Coffee Pot" window, and if you know your boomers you will see a couple here. That haven't been parted in 25 years; I know, because I have worked all around with them. There are two boomers in Philly who drive a truck to New York every night. Two more are on the trolleys. Another is a doorman for a movie theater, dressed up like a German general. Still another is a yard office janitor.

The Eastern boomer's greatest fault was getting hungry or dry. Brothers, I could make you shed salty tears if I'd tell you how some boomers starved, and how long some of 'em went without drinks. But I won't make you feel bad now.

The runaway trains weren't all out West, either. One time I was working out of Albany, N. Y., on the old West Shore. We were coming down the hill into Albany when the old eagle-eye began to roll the crummy around. Says the con: "They got away from that long necked so-an'-so." We hit the deck, grabbed our clubs, and started over 40 cars of coal. We met the head man, and we wound 'em up two men to a club, but still we went faster. The fireboy came out to help. I rubbed my rabbit's foot and hoped the yardmaster would have the main line clear.

But we began to slow when we reached it, and the hump-backed old hog stopped with her nose near the new D. & H. building. I grabbed the club from the con and went ahead to visit with the long-necked engineer. The whole crew was there in time to see the hero hogger. He was shaking and his face was white as paper. He couldn't talk, so we talked to him. We later found out the air was frozen five cars back.

Next day the trainmaster called it quite an adventure. Adventure, hell, I told myself; if that was an adventure I didn't want any more.

The hired hands on the West Shore had a lot of other names for it, some of them not so nice. In the old days it had a bunch of cars, trucks, ties, etc., and a flock of low-wheeled hogs that could haul 45 cars if the cars were empty. When a crew was called they took overcoats, summer underwear, and whatever else they could carry, along with a grub basket that held enough to last a month. If they left Weehawken on the first of the month they usually wired back from Kingston on the 15th to see if the family was well and if the cat had kittens yet. With plenty of good breaks they would hold the main at Ravenna on account of plugged yard about the time the oldest boy was ready for high school. It was 140 miles from Weehawken to Ravenna.

Some years ago I made the voyage to Weehawken and saw the trainmaster. After a lot of sassy cracks about railroad tramps, he gave me a fistful of blanks to fill out, and remarked I had worked there 50 times in the last five years.

But he was a liar; as I remember, it was only 20.

I made a lot of scratches on the papers that nobody could read, and the clerk shoved them through a hole in the wall. I'll bet it led to a garbage can on the other side. It just as well might have.

I was called for 5 A.M., but we hadn't got into the Weehawken tunnel before we stopped for two hours because a couple cars of cinders and a flat were on the ground. Finally we got going and made Cornwall, where the New York, Ontario & Western switched off our main line and ducked over the mountains somewhere.

When we got to the water plug at Cornwall

we were four times back; that is, four trains were lined up to get a drink ahead of us, and the train in front of us was an O. & W. It started, stopped, and waited an hour. I finally got impatient and hiked over to see what was up. The O. & W. train was on the ground. It was three hours—almost 5 P.M.—before they discovered a big hook and got her on again. We had made 50 miles in 12 hours. How's that, brothers?

Our pig was No. 140 or 142, and she was an awful lawnmower. At Newburgh she began to clinker, and she finally stalled on a little hump. When finally we arrived at Kingston, we were just in time to meet the dogcatcher. Seventeen hours to go 90 miles!

We had long trains, too, out East, 'way back in 1910. When the Mohawk crews of the N. Y. C. were called, the engine crew was called an hour ahead of the trainmen, who caught the crummy as it went by the yard office in West Albany, when the head end men were over in Schenectady someplace. But no kiddin', gents; in the fall and winter when the grain rush was on, it was something to write about to the boys up at Devil's Lake on the G. N. A man had to be some relation to the 7th assistant vice president to lay off. Why, the trains were so close that the front brakeman lived in the caboose of the train ahead of his.

As for the Pennsy, did any of you brothers ever leave West Philly with all the cars the Pennsy ever owned or borrowed, and try to get some place? You're the rat hole artist, and you have a rotten old hog that could hardly pull herself. You take turns with the hogger and head man to keep enough fog to work the gun, let alone enough to haul a heavy train. You make Frankford in about two hours, and Frankford is not even out of the city. You follow the tramps ahead, over crossovers and back, dodging the hot shots. Twenty-seven hours later you arrive at Jersey City—27 hours for 85 miles! No wonder the boys went over to fight the Kaiser; it was easy compared to fighting the freights at that time. Nope, brothers, railroading in the West hasn't got a thing on railroading in the East.—"LINK & PIN RELLY," 35 Wyneva St., Philadelphia, Pa.

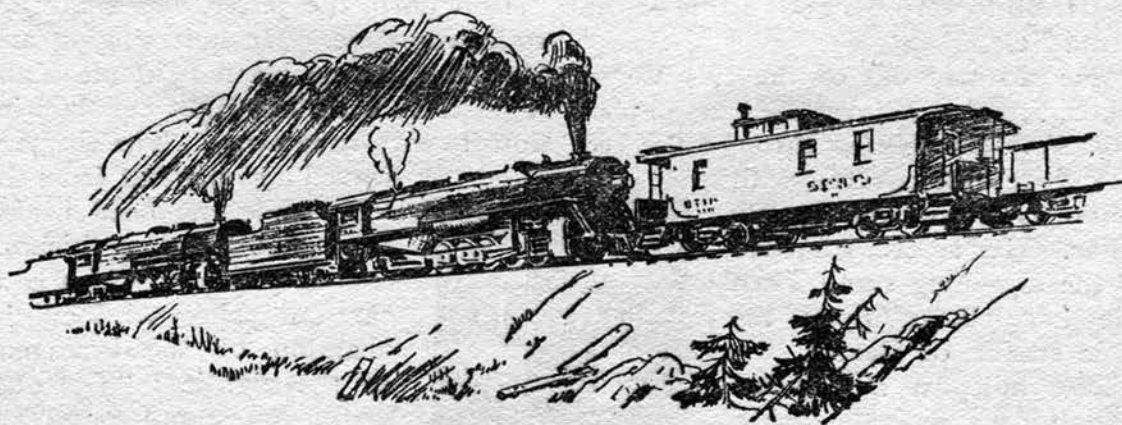

# Longhorn Lannigan

By ED SAMPLES

**AUTHOR'S NOTE:**  
Most of the Incidents in This Story,  
Including the One About the Bull,  
Actually Occurred  
on the New Mexico  
Division of the  
Santa Fe.



**T**HE westbound freight was behind time. Engineer "Longhorn" Lannigan knew it. Fireman "Squint" Schrader, Conductor Jimmie Kane, and the brakemen knew it. Even the No. 282 seemed to know it and to be trying with all the pride of a new Consolidation to save the good name of the Santa Fe.

She stormed out of the Las Vegas yards, thundered down the canyon past Romero. She blared through the red sandstone hills covered with piñon, juniper, and scrub cedar. Her siderods flashed in the low-hung sun. Then she bore down upon the little station of Bernal.

The milepost zipped by. Longhorn Lannigan looked

at his watch and called to the fireman: "Hi, there, Squint! You want to git this ol' teakettle poppin', because we're goin' to Rowe for the Pacific Mail."

Squint went into the deck.

Longhorn, the jester, was singing a rollicking tune. He quit singing and blew the station blast. Jimmie Kane highballed from the right cupola window twenty cars away. The flagman waved a slouch hat from the left, while the head brakeman flourished a hickory club from the top of a box-car and yelled with all the abandon of the brakeman of the eighties: "Git outa town, you son-of-a-gun!"



Longhorn reached again for the whistle cord. Then he turned to thumb his nose at the brakeman on the car behind, laughed when the boomer thumbed back, and renewed his song. The east switch crashed. Adobe huts and a station spun behind his right ear. The Chapelle Mesa swirled out of sight as the freight took the curve and raced for the bridge and the cut beyond.

"Look out, Squint! We're goin' to hit 'em!"

Squint didn't ask what they were going to hit. A dozen times since he had gone firing for Longhorn he had heard

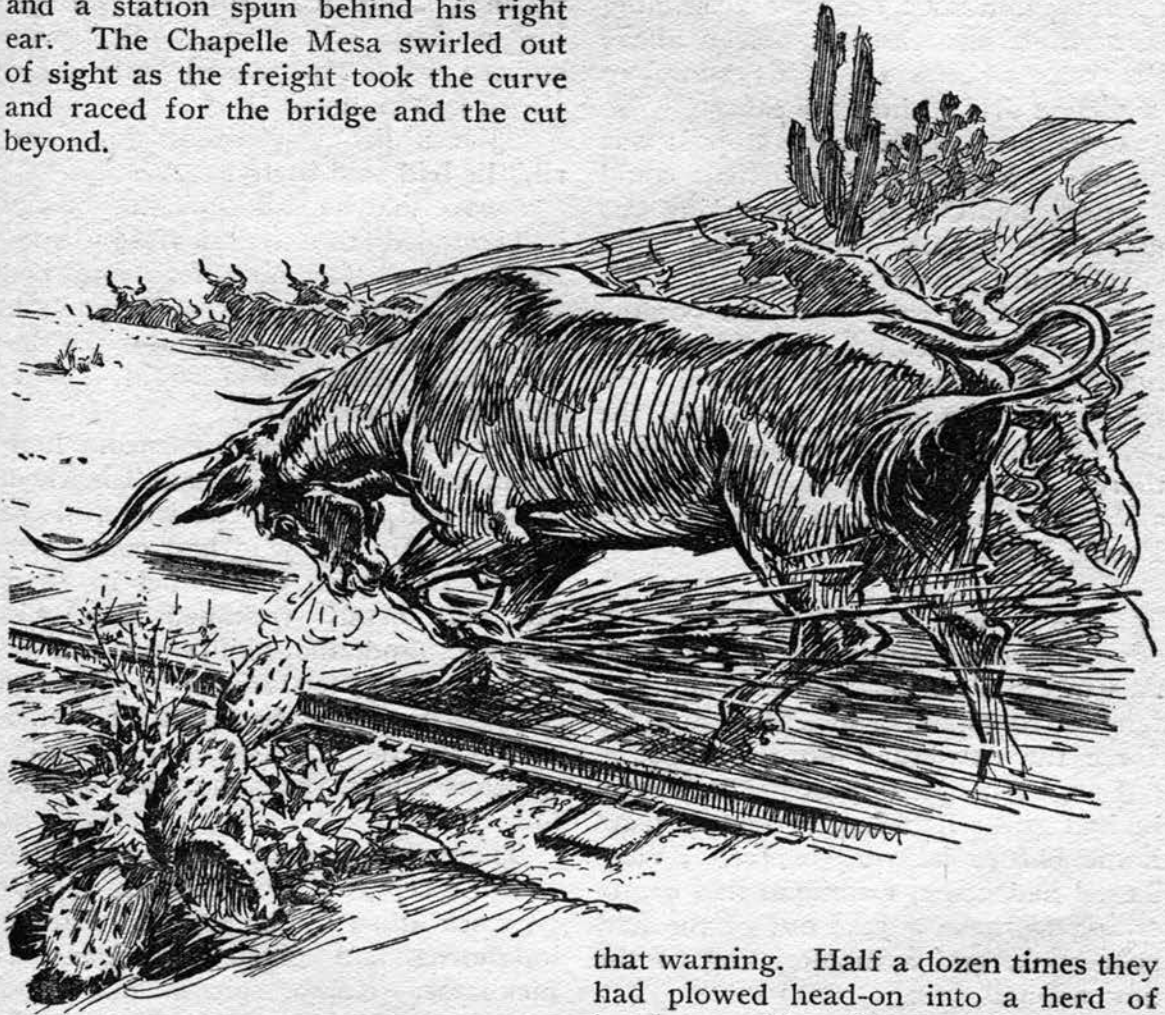

Over the bridge and through the cut the Consolidation rocked and rolled. Ahead lay the straight stretch leading away to the west. Longhorn shielded his eyes from the western glare. Under the sun a moving mass of white and crimson loomed in the track ahead.

He sprang to his feet. His hand shot up to the whistle cord. He screeched into the rocking deck:

that warning. Half a dozen times they had plowed head-on into a herd of longhorn cattle. But none knew better than he that if one of those steers ever tried to retaliate by falling flat into the track instead of hurtling sidewise, it would pile him and Longhorn and a freight hog and a string of box cars all over the right-of-way.

He flung his scoop to the deck. Bating his glazed eyes, he leaped to the left gangway, stood ready to jump if this should be the time.

The whistle howled. Cattle spilled down the embankment. They boiled over each other on the right-of-way.

But one lone bull refused to budge. Squarely in the middle of the track he stood, head down, tail up, front feet catching hunks of ballast and sending them high into the air. Even above the roar of the train his rumbling challenge drifted into the cab.

Longhorn did not try to stop. It was no use. Before the brakeman could have set a single brake, the engine was upon the defiant brute. The pilot caught him between the knees. His bulk shot backward over the pointed nose, lammed into the smoke box, and hung poised for a split second. He rolled, fell flat on his back, and the last Longhorn saw of him he was lying there. Longhorn grabbed his throttle and roared on, going to Rowe for the Pacific Mail.

**T**HAT bull turned the trail for Longhorn Lannigan. A year ago, A. Lincoln Terril had come as superintendent to establish discipline and enforce the new rules on the division.

Longhorn hated rules. That's why he had quit school and run away from home before he was twelve. When Terril had come, Lannigan had begun trying to make a joke out of the new rule book, and a monkey out of the new official.

His pranks had not been serious. There was, for instance, the day he had stopped his engine under the office window and in defiance of Rule G had fished from his hip pocket a flask, turned it up, taken a long pull, wiped his mouth and slipped the bottle back into the pocket. A second later he had looked up, had caught the eye of the new super, and had almost fallen off his seat in mock consternation.

Of course the trick had worked. A. Lincoln Terril had not been used to Longhorn's kind. He had stormed down the stairs, leaped into the gangway, angrily demanding "that damned bottle." With an air of injured innocence, Longhorn had fished from his hip a flask which was filled with colored water and spiked with sugar, cloves and cinnamon!

"Jist a little substitoot, Mr. Terril," he had said softly.

Aware that he had "bit," the official had bounded from the cab and returned to his office. Grinning, Lannigan had fished the real thing from behind the seat box and taken one, "To the one and only Abraham Lincoln Terril! May he live and learn!"

Terril had lived and learned. Lannigan had lived, but he hadn't learned. At the end of a year he was still the same playful kid who had come over Raton Pass with the tunnel in 1879. He still firmly reckoned that wit, courage, and the ability to run an engine would keep him on the job when the rule book boys had passed into history. But he didn't know that homely division super, nor the men behind him.

The new rule book required reports—work reports, time reports, reports on stock killed by the engine. Hitting longhorns had given Lannigan his nickname. Rumor said he had killed more cattle than any engineer on the division, yet not one report of such accident had he turned into the office.

Terril began demanding reports. At the end of the year, there was a quarter-inch of "Please-explain-why" carbons in Longhorn's file, and a week ago Terril had had him on the carpet and had warned him that one more failure to furnish required reports would lead to serious consequences.



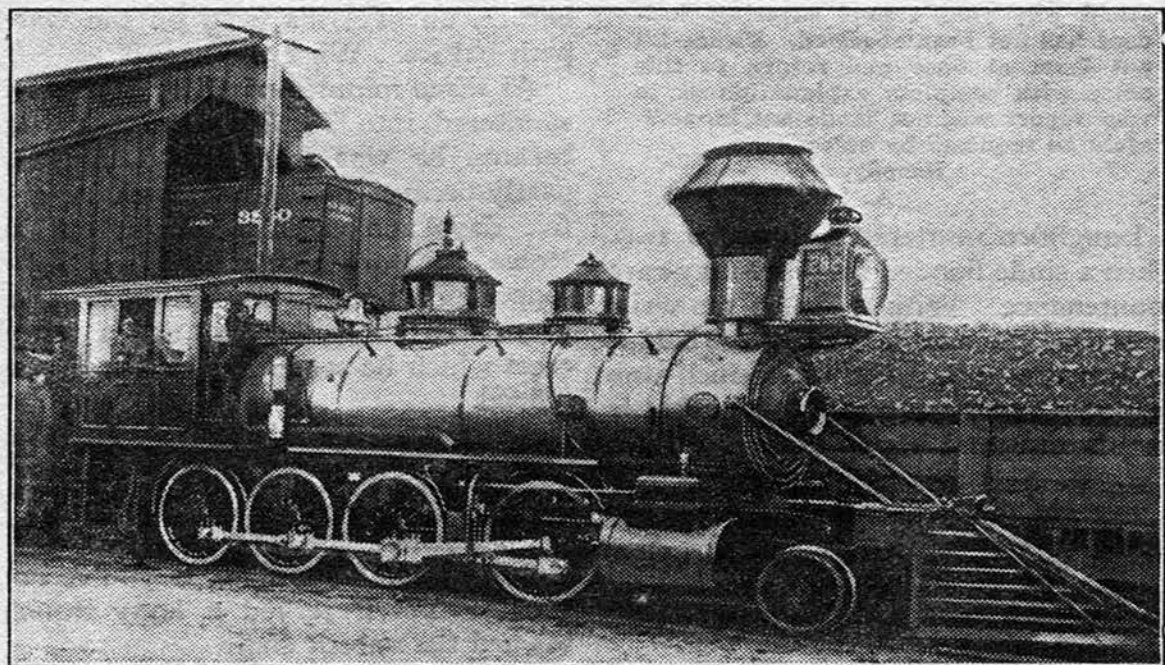

Longhorn Lannigan's Engine. This Santa Fe Old-Timer, No. 282, Actually Participated in Some of the Events Narrated Here. Story Based on Facts, with Names and a Few Other Details Changed. Photo Made in 1882 at the Coal Chute in Las Vegas, N. M.; the Original Belongs to Byron Archibald, a Retired Engineer Now Living at Las Vegas

WHEN they headed in at Rowe for the Pacific Express, Conductor Jimmie Kane came to the engine. Longhorn was on the ground with his oil can.

"You got another one, did you Longhorn?" the captain asked.

"Yep."

"Hurt it any?"

"Ain't been around yet to see."

Longhorn set his oil can down. The two men went around the pilot. A couple slats were splintered. The front end of the engine was smeared from pilot to smokestack. The glass was knocked out of the headlight.

"Ain't that a helluva purty mess!" Longhorn lamented. "Here we had this gal all shined up like she was going to a weddin', an' lookut her now!"

"You'd better git busy an' make a report on this un, Longhorn," Jimmy advised.

"What'n hell's the use makin' a report. Ol' Funnyface'll know more about it than I do before I git to Wallace anyhow."

"Yore funeral, Longhorn," Kane said with a shrug. "Yore funeral, not mine."

The crew went to Wallace\* and back home. Next day they made a Glorieta turn and arrived back at Las Vegas a little after dark. Longhorn fished from his mailbox a letter on company stationery. He read it and grinned.

Las Vegas, New Mexico

To Engr. L. H. Lannigan

Dear Sir:

Beg to call attention to fact that on the 26th inst. train X No. 282 struck and killed near Mp 678-25 one three year old bull bearing X-bar brand.

Records show you in charge of eng. 282 at time of accident. Cannot under-

\*Wallace, now Domingo, was the division point till 1887. Then it was changed to Albuquerque.

stand why your report covering accident has not been received. Please fill out form at once and return to this office with complete explanation as to why report was not made out immediately as required by rules.

Respfly,

A. Lincoln Terril

Longhorn muttered a damn or two. Then a smile flooded his devil-may-care countenance. With a flip of the wrist he turned the manila sheet over, held it against the wall, fished a two-inch stub of pencil from under a half-pint bottle on his hip, and scribbled:

Mr Abraham Lincoln Terril

Deer Mr Terril:

i sideswiped the bull. i might of killed him. i didn't back up to see. why i didn't report was because i figured you'd know it anyhow and which you did.

Affectly

Longhorn Lannigan

P. S. Plese excus this unformal report, as i have not got the blank handy.

A thin smile wrinkling the corners of his audacious mouth, Lannigan sealed his "report" and slipped it through the slit marked "Supt. Mail."

HE was called for a westbound drag at 7.50 next morning. The fresh grin cracked into a chuckle as he recalled the joke he had played on the super. The grin withered when he read the first message he picked up in Rowe:

To C & E X282 West c/o Opr Rowe:  
Turn at Glorieta—ALT.

Longhorn had expected to go to Wallace. He read the other message.

To Engr Lannigan, c/o Opr Rowe:  
Please report this office tomorrow  
8.00 A. M.—ALT.

"When a high hat turns a crew to git a man on the carpet," Lannigan muttered, his face sober now, "he must be on the warpath." He wadded the message up and stuffed it into his pocket. "Oh, well. I been on the rug

before, an' Terril's been on the warpath before. What the heck!"

At three minutes of eight Longhorn sauntered into Terril's office. Partly because he was Longhorn Lannigan, partly because he figured he would get five days and catch a freight out to Rowe, he wore hiking breeches, high-topped boots, and a corduroy cap. He also carried a fishing rod and a fancy creel which he set in plain sight of the official.

Terril was signing letters. His jaw went down.

"Going fishing, Lannigan?"

"Yes, sir."

"Sit down, Lannigan, if you've got time." Terril jerked a bony thumb toward the vacant chair.

Longhorn sat. Terril flipped the letters aside, picked up a letter opener and gouged it into a blue blotter. His flattened nose was distended for a second, but the spasm passed.

"Lannigan." The voice was like the pelt of sleet on a tin roof. "Lannigan, why didn't you report that steer you killed down by Bernal Sunday?"

"Why, didn't I report that, Mr. Terril? I thought I mailed the report las' night."

"That was not a report, Lannigan. That was an insult."

"Well—"

"Lannigan, I want to know why in open defiance of rules, and in spite of the fact that you've been warned a dozen times to report stock you hit, you still refuse to do so. Why didn't you report killing that steer?"

Longhorn squirmed. He didn't dare tell why. He racked his brains for an excuse, for something in the death of that—Ah, wait a minute! Worry left his innocent eyes, and the audacious smile came back.

"Well, suh, Mr. Terril, yuh see it

was like this. When I seen that bull in the track, I *thought* we was going to kill him. When we sloughed into him, I thought for a minute we had killed him. But do you know what that bull done?"

**T**HE official did not reply. The engineer had not expected him to. Longhorn continued:

"Well, suh, Mr. Terril, when we hit that bull, he come right up on our pilot, set there for a minute, an' loped off to one side an' landed flat on his back, an' the last I seen of him, he was wavin' all four legs. I supposed that he was all right."

"Stop!" thundered Terril. "You can't stand there an' lie to me! I know why you did it. You think because you can run an engine, and get by with the girls, that you can also bluff and bully the officials of this company. Lannigan, I'm telling you for the last time you can't."

"You've brought your fishin' outfit down here figgering you'd kid your way out of this like you've done before. Take it and get out. I'm giving you thirty days to fish and think it over. If you can come back and railroad by the book, come on. If you never come it'll be ten days too soon to suit me."

The audacious grin left Longhorn's face.

"Don't you think, Mr. Terril, that—that thirty days is pretty stiff?"

"Don't argue with me, Lannigan. I'd be justified in firing you. I don't know why I don't. I've had you in this office twice a month for a year trying to make a railroad man out of a fool kid. This is your last chance. Now grab your stuff and go on fishing."

Longhorn went fishing. He rode the freight to Rowe, then went far up to-

ward the headwaters of Cow Creek. Here, for 27 days, he lived in an open-faced camp, tramping hills and streams, prospecting, fishing, thinking it over.



Broken Rules

**O**N July first Longhorn returned to work. He scuffled with the girls, swapped yarns with the boys, wisecracked about the "joke book" and the "brass hats." Because they could not see behind the audacious smile, the boys thought 30 days had not tamed him. Only clerks who now found neatly made reports where before had been blotches suspected what had happened; before the rest had time to discover it, the crash had come.

July Fourth. A big excursion to Santa Fe. Special trains from Trinidad, Raton, Las Vegas and Albuquerque were run into the capital.

Longhorn caught the Trinidad train. That was a treat. He made his day's pay; he had a good time; he met new people.

The main line of the Santa Fe Railway never got into Santa Fe. It passed through Lamy, 63 miles southwest of Las Vegas, and an 18-mile branch ran from Lamy into Santa Fe. When the crews put away their trains in Santa Fe that morning, they joined the merrymakers in the narrow streets.

Longhorn met a beanery queen whom he had known at Trinidad while he worked on the Raton tunnel. He paired up with her. Squint and the brakeman picked a couple of girls from Denver who had come with the Trinidad crowd.

An hour before its setting, the sun slid into a bank of cloud hanging over the Jemez Mountains. The crews went to prepare trains for the return trip. While Longhorn oiled the No. 282, the brakeman came to the engine. With him were two girls from Denver. He called Squint aside, and the four went into a huddle. When they emerged, Squint approached the engineer. The girls were with him.

The fireman said, "Longhorn, I want you to meet a couple uh my friends. Miss Sanders, Mr. Lannigan. Miss Frazier, Mr. Lannigan."

Puzzled, Longhorn acknowledged the introductions. In the past neither Squint nor the other boys had gone far to introduce him to their lady friends, because when he was there he was usually first out with the women.

"Longhorn," Squint whispered, "the ladies would like to ride the engine with us tonight. Reckon we could carry 'em?"

Longhorn wiped the spout of his oil can with a fistful of waste. Hauling ladies was strictly forbidden by rules. He *had hauled* plenty of them. Still—

"I dunno about that, Squint."

"Yuh see, the ol' man . . ."

"I haven't saw you paying much attention to the ol' man in the past, big boy."

Longhorn winced.

"But this is a excursion train, Squint. Suppose the brass hats are—"

"Brass hats won't ride this train," assured the brakeman. "They'll all stay here till the last dog's made into chili. Of course, if any of 'em should get on, we'll tip you off."

"Oh, pleathe, Mithter Lannigan!" Little Miss Frazier was speaking earnestly. "We've never been on an engine. We do tho want to wide with you tonight. The boyth have been

telling uth what a wonderful engineer—"

Longhorn was weakening. He looked at his watch.

Squint said, "It'll be all right, Lannigan. Like Red says, if anybody gets on he can give us a tip."

Red went back to load passengers. The girls stood by the driving gear. Their soft eyes pleaded.

"All right," Longhorn said. "We'll take a chance. You girls ride the coach to Lamy. That's eighteen miles. It'll be dark when we get there. We head out on the main line for water. You just skeedaddle off the blind side and come to the engine. If the coast's clear, we'll take you into Las Vegas. Is that all right?"

It was.

WHEN they reached Lamy the cloud from the Jemez had swooped up to obscure the heavens. Lightning darted over the mesas. Ominous, rumbling thunder quivered through the canyons and echoed from the rimrock.

The girls were in the head car. When Longhorn spotted his engine at the water plug they elbowed their way out, sneaked up the dark side of the train. Longhorn urged them to return to the coach. He told them it was going to rain, and warned them they would ruin their dresses, but they held him to his promise.

Gene Frazier had black hair, sparkling eyes, a lisping tongue. Leaving Lamy, she came to the right side of the cab to help "Mithter Lannigan wun the engine."

The storm struck.

Little Miss Frazier was scared. She would never have admitted it; but Longhorn could feel the quiver of her body close to his on the narrow seat.

He had ridden engine cabs through worse storms than this; still, he could not shake the feeling that something was going to happen.

As they roared up through Canoncito, he fished a half-pint out of his grip. Smiling, he offered the flask to the Frazier girl.

"Better take a little bracer to chase away the jitters," he said.

She gasped. "Oh, Mithter Lannigan, I couldn't do that!"

Longhorn chuckled. He took a swallow and returned the flask to his grip.

Those excursion trains owned the railroad that night. The dispatcher put everything in the hole for them. With a clear track, a fast schedule, and two ladies in the cab, both scared witless, it would have been the chance of a lifetime for a grandstand run.

But Longhorn resisted the temptation. Taking chances on a train packed with human beings was something he did not do.

It was 10.30 when they topped the Glorietas. The storm raged in the lonely pass. The pusher engine cut off. Though the girls gladly would have returned now to the coach, the storm would not let them. With an uneasiness foreign to his soul Longhorn let the train roll out of Glorieta and start down the mountainside toward Rowe.

Through the closed front window he could not see beyond his pilot. He moved Gene Frazier forward. She cowered close to the cab frame to give him room. He crowded into the seat behind her, opened the side window and thrust his head out into the darkness.

To relieve the girl's terror, Longhorn wisecracked. He had her blow the whistle for curve and crossing. But

every inch of the way he was alert.

They descended the grade in safety. The tension lessened. Longhorn let the engine out through the foothills. They raced along the track where today block signals lift sentinel arms to guard each train in its passage. They stormed along toward Bernal.

Longhorn began to breathe more easily; but he did not relax his vigilance. He peered ever into the pouring rain. He chuckled when he passed the place where he had killed the last longhorn bull. Then his eye grew grave, when he recalled how A. Lincoln Terrill had warned him for the last time.

THERE was no "hog law" on the railroads in the Eighties. Crews did not quit when they had worked sixteen hours. During the rushes they worked as long as there were trains to be moved and engines to move them with. They made trip after trip over the road, sometimes sixty hours on end, sometimes even more. They went until it was humanly impossible for them to stay awake, even though their own lives and the lives of others depended upon vigilance.

Around holidays and pay days the pinch came. Boozers marked off "sick." Drifters drew time and left town. The burden of traffic fell upon men who made railroading a profession.

The Santa Fe, reaching out for Pacific coast connections, had built through Nogales and connected through the Sonora Railway to Guaymas on the coast of the Gulf of California. That year a drought had started a cattle rush out of Mexico.

The rush hit the Santa Fe about the time Longhorn returned to the job. Every crew on the division was working overtime; and when the excursion

took four crews out of service, the pressure was increased for those who had to work the freights.

At noon of the Fourth Jimmie Kane was in Wallace. He and his crew went to bed in the caboose. At 2.30 p. m. they were called for a drag north.

"Surely we don't have to turn again!" exclaimed Jimmie. "We turned night before last in Vegas. We turned here yesterday. We turned in Vegas again last night. We're dead on our feet; can't stay awake another night."

"Quit yuhr crabbin'!" barked the caller. "Yuh're on the railroad now. If yuh want to sleep, go back to the farm."

At 4.00 p. m. they left Wallace. They staggered up to Lamy, got coal and water and a bite to eat. They left Lamy at 6.10, two hours ahead of the Trinidad Special. They crawled up through Canoncito and doubled into Glorieta.

With only four cars of air next the engine, the trainmen had to "decorate" —to ride on top and hold the train with brake clubs. Every one of them went high, keeping those cars under control in the face of the rising storm. Half-way down the storm struck them. The downpour soaked them to the skin.

Leaving Ribera the hind man returned to the caboose. He and Jimmie dried out a little and went into the "dog house" to watch their train.

"We'll head in over at Bernal and let the percession by," said Jimmie.

"I hope we git stuck there till noon tomorrow," crabbed the brakeman. "If they won't let us sleep in terminal, maybe we can get some shut-eye on a side track."

Windy hung his lantern on the hook outside and fell back on the cushion. Jimmie yawned and opened the side

window so the wind would blow into his face and keep him awake.

It was pleasant in the cupola. Rain-drops beat a lullaby on the roof. Soon both men were sleeping. They were aroused when the engineer whistled for Bernal. Rules required trainmen to be on top of trains "ascending and descending all grades, approaching stations, and water tanks, and heading into and out of sidings."

They knew the rule. When the whistle sounded, Windy sat up like a sleep walker and reached for his lantern.

"Set down, kid," Jimmie said thickly. "No use decoratin' here. Hoghead'll handle 'em with his air."

That was true. The siding was nearly level. There would be no brakes to set. Windy did not need much urging. He dropped back on the cushions. He did not intend to go back to sleep until he had closed the switch. But the warmth and the rain were lulling. Soon both he and the conductor were sleeping.

The engineer pulled slowly into siding. He did not stop the train until it was in the clear. Jimmie and the brakeman were so dead they did not know when their caboose ran over the points. The switch target threw flickering streams of red along the main line. The switch was standing open, with the wall of falling water hiding the warning gleam behind an impenetrable curtain.

In their cupola the two men slept on. Minutes passed. A sound came out of the night. Jimmie snapped awake. He did not know what had disturbed him. He sat up and rubbed his eyes. The sound came again. It was the rain-soaked whistle of the No. 282, blowing a crossing blast. Jimmy grabbed Windy by the shoulder.

"Did you shut that switch?" he screeched. "Did you shut that switch?"

Windy came from dreamland. He tried to claw open the cupola window to get his lantern. The conductor leaped to the floor, caught up the red light as he went out the back door.

He raced for the open switch. He was late. When he was halfway to it, the glimmer of the headlight broke through the wall of falling water. The Trinidad Special was into them.

LONGHORN whistled for Bernal. He was working No. 282 wide open. He let Gene Frazier blow for the crossing. He watched for the green light of the west switch. No green was showing. He tightened his grip on the brake valve. The splotch of red flashed out of the night. He twisted the valve and grabbed the whistle cord.

The girl saw the still splotch of red flick out of the rain with the moving one of Jimmie Kane's lantern beyond it. The signal meant nothing to her. Longhorn leaped to his feet and set the brakes in emergency. He caught the whistle cord, but she only laughed. He jerked his head left and shouted to his fireman:

"Jump, Squint! We're into somebody!"

Even then Miss Frazier thought he was joking, was trying to scare her; and when he caught her in his arms to shield her from the impending crash, she fought him like a tigress until the engine hit the open switch.

The engine split the switch and spilled all over two tracks. The head coach nosed it along, crawled atop the boiler and stopped right side up with its nose tilted toward the dripping sky.

The passengers were shaken and

bruised and battered. No one was killed. The two girls in the cab got off with scarcely a scratch. Squint suffered a twisted ankle and a broken nose. Longhorn came out with a wrenched back, a broken arm and some broken ribs.

Of course Terril held court. He fixed the blame for the wreck on Jimmie Kane and the hind brakeman, and fired both of them. He secured statements from passengers who'd taken two men and two girls out of the cab. He secured statements also from Miss Frazier and Miss Sanders. But both had poor memories. Neither of them remembered exactly how she had got into the cab of the engine.

If Lannigan had not been on the carpet before, the super might have let the matter drop, or someone might at least have tipped off the boys as to what the girls had told. He did neither. As soon as Squint was able to come down, Terril had him in the office.

"Schrader," the prince said tartly. "I want to know why you and Lannigan had those two women in the cab with you the night of that Bernal wreck."

"What women?" The fireman was perfectly innocent.

"You know *what* women." Terril was positive.

"Why, I don't remember nothing."

"Listen, Schrader. If you're deliberately lying to me, quit it. If you've forgotten, let me refresh your memory. When train X No. 282 turned over that night, there were in the cab with you and Lannigan a Miss Emma Sanders and a Miss Gene Frazier. I know they were there, because I have statements from passengers who helped remove them, and I also have statements from them."

He forgot to tell Squint the girls did not seem to recall how they had got in the cab. Certain the cat was out of the bag, Squint told the truth. Since it was his first time on the rug, he got thirty days and a hot lecture.

IT was October before Lannigan was able to go to the office. He knew when he went that his days were done. Gone was the audacious smile from his face.

Terril shook hands with him, ushered him in, shut the door and said, "Sit down, Lannigan."

Terril leaned back in the swivel chair. On his face was no leer of triumph, no bluster; only the calm determination of a man whose will must be obeyed.

"Lannigan," he said, "on the night of July Fourth, you and Schrader carried a couple of women with you from Lamy to Bernal."

"Did they tell you, Mr. Terril?"

"They did not have to tell."

Longhorn said, "Yessir, Mr. Terril, we hauled them."

Longhorn did not try to blame Squint and the brakeman. He played with his cap, scratched a red scar on his forehead, watched scattered snowflakes. Terril clasped his bony hands on the desk.

"Is an answer necessary, Mr. Terril?" he finally asked.

"Not from you, Lannigan. I know why you did it." Terril thrust his scowling face into the sober one of the engineer. "I had you in this office three days before and told you that if you deliberately violated another rule of this company, you were through. Carrying those two girls happened to be the first violation that came handy, the first thing that came into your head. You did it to show me."

"No, suh, Mr. Terril. That wasn't why I did it." Longhorn crossed his legs. Terril leaned back in the chair.

"Then *why* did you do it?"

Longhorn was silent many seconds. He considered trying to explain that he had done it under protest, that the boys had reminded him of previous violations of which he had been guilty. He decided not to. Instead he said, "I have no reason I care to give, Mr. Terril."

"All right, Lannigan." The official removed a yellow sheet from a clip in the file. It was a "clearance," a service letter. It gave the details of Longhorn's employment on the New Mexico Division. In the place headed "Reason for leaving service" were four words: "Discharged for insubordinate conduct."

Longhorn read it. He flipped the letter back on the desk.

"I'll never be able to get a job on that service letter, Mr. Terril."

"You should have thought of that a year ago, Lannigan. I warned you. You refused to listen. But I hope you find a job and act like a man when you get it."

Longhorn looked at the official and said: "Me too, Mr. Terril."

Then he limped slowly up Sixth Street. And with the heaviest heart he had carried in his life, he rode the cushions eastward.



#### Down Glorieta Hill!

A LINCOLN TERRIL finished organizing the division. He did a good job of it, so he went west to "organize" another division.



Longhorn went East. He fired for the Missouri Pacific, for the Memphis Route, for the Iron Mountain, for the I. C. Months grew into years. He remained nowhere long enough to receive promotion.

Always the Santa Fe was calling. Maybe it was the lure of spring in the Glorietas. Maybe it was the mystic atmosphere of New Mexico, with the sunshine glistening on its towering peaks.

Months after Terril had been called West, Lannigan returned to Las Vegas and asked for a job. The new officials did not know him. The master mechanic put him on firing.

By this time the board lineup had changed. Men had come, men had gone, men had been promoted. Longhorn made three trips before he met a single man who had been here when he had gone. Then he was called on a January night to go west with Squint Schrader. When he swung up the steps Squint gulped and swallowed as if he had seen a ghost.

"Well, well! If it ain't ol' Longhorn back on the job!" he greeted.

"Yep." Longhorn took the extended hand. "Plugged nickels an' wooden-legged chickens always comes home."

Longhorn shook the grates and spread the coal. Squint oiled around and came back to the cab. The bitter cold of the mountain night stabbed through the gangway. They pulled down the storm curtains and reminded each other of other nights they had worked together. Squint's laugh was loud. His nose was red.

"Gene an' me's often talked about yuh, Longhorn," he cackled.

"Gene?" The name struck Longhorn with a ring of familiarity.

"Yeah. Gene. Surely you remem-

ber the little girl we hauled from Lamy the night of the Bernal wreck."

"Oh, sure. Is she—"

"She's Mrs. Squint Schrader," the engineer crowed.

"The devil she is!"

"Yessir. We've often wondered whatever became of you. Gene, she's said lotsa times that if it hadn't of been for you pullin' her outa that hole, she probably have been smashed like a pancake between the cab wall and the reverse lever."

Conductor Red Waters came with the orders. He was painting the air blue.

"What's the matter now, Red?" Squint asked. "Did somebody put a icicle down the back uh yore neck?"

"It's these here damn Indians. That White Horse John an' his squaw's come down here wantin' to ride this freight to Wallace. They couldn't possibly wait till mornin' an' ride a passenger train. That's jist like a Indian."

Red kept raving. Squint told him Longhorn Lannigan had returned to the mountain. Red shook hands.

**I**T was dark when they left Las Vegas. Ice daggers pointed downward from the water tank, and fierce winds whipped blown snow through cuts and sifted it between switches.

Longhorn had never entirely recovered from his injuries at Bernal. His broken arm was stiff. His kinked back was still aching. When bad weather brought rheumatism to his injured joints, he often had trouble to feed the firebox.

That night was a grilling one. Squint was not an engineer. He was a hog-mauler. Longhorn had always known he would be. He let the Johnson bar into the corner and literally

"beat hell out of her" on every grade.

More than once Lannigan looked at the man he had taught to fire an engine. Squint slumped in the seat, now nodding, now whistling to keep awake. Not one time did he offer to take a turn on the scoop as Longhorn had used to do before their positions had been reversed. Lannigan ached to get hold of the throttle, to take those sags on a run that would put them over the humps without dragging. But he didn't open his mouth. He let Squint Schrader run the engine in his own way.

Frost whiskers on the steel rails made them like glass. The drivers had no traction. They struck the hard pull. Longhorn had his fire thick on the grates. It was not thick enough. The engine stumbled, lost her footing. Her fire went to her front end and out her smokestack. Squint cursed and yelled. The needle fell back, and the drivers slipped again. The train stopped. They had to take the train into Glorieta in two pieces.

When they came up the hill with the rear end Squint went into the caboose for a cup of hot coffee before starting down the long slide into Lamy. Longhorn went with him.

Wrapped in blankets, White Horse John and his squaw were curled up on bunks. Lusty snores filled the way-car. The squaw's right cheek was exposed. Longhorn grinned, yanked a straw out of the broom and tickled her.

The squaw turned stupid eyes to stare up at the men. Lannigan was busy emptying a tin cup. She covered her cheek with the blanket, grunted disgustedly, reversed and snored again.

Red Waters looked at the returned pilgrim.

"I see yuh ain't changed a helluva lot, Longhorn," he commented.

"Some," Longhorn replied softly.

The crew emptied the coffee pot. Because it was cold, because there was a bitter drag ahead of them, Red brought a bottle from the locker. Squint had partaken before leaving Las Vegas. He helped empty the bottle.

"I don't begrudge yuh the lick, Squint, but yuh better tap that kinda light," Red said. "There's a lot of slick steel between here an' Lamy."

"Keep yuh mittens on, ol' bean. This boy knows when he's got enough."

Probably he did. Probably it would have made no difference if he had not even smelled a cork. The rails were slick, and with the added load of company coal which they took off the storage track, they had more tons than one crew should have taken down Glorieta Hill on a winter's night.

**L**ONGHORN'S heavy work was done. He watched Squint with critical eye. The engineer did not start a train down Glorieta as Longhorn would have done. He let the speed climb, five miles an hour, eight, ten.

Out on the cars the brakemen worked with hickory clubs. The two men in the engine could see their lights as they leaped cars covered with ice and snow. Their progress was slow. They were stiff with cold. Every wheel they touched froze to their mittens and stiffened their fingers.

Squint was wide awake. He knew what he was doing. He watched lanterns and telegraph poles. He looked at his watch. Longhorn would have used air, but he was not running the engine.

When they were doing twelve miles an hour Squint made his first brake application. It did not seem to affect the speed of the train. He released

and made another. Ordinarily this would have done the work. The grip of a few air brakes added to that of the hand brakes the men had set would have checked the momentum.

Tonight the drag kept right on. The drivers were skidding. Longhorn could feel them. He looked at the air gage. Squint used sand to break the ice coating and stop the skid. He was getting nervous. He released the brakes again.

They were off for but a brief interval. In that interval the train picked up to twenty miles an hour. Squint sloughed the air again. The

wheels locked and skidded. Squint left his throttle and crossed to the fireman's platform. He was blinking and looking foolishly at Longhorn.

"Whut—whut's the matter with this damn outfit?" he queried.

"Ice on the rails, my boy," the fireman answered shortly. "Didn't you know it was there?"

They Were Running Away! He  
Aroused White Horse John

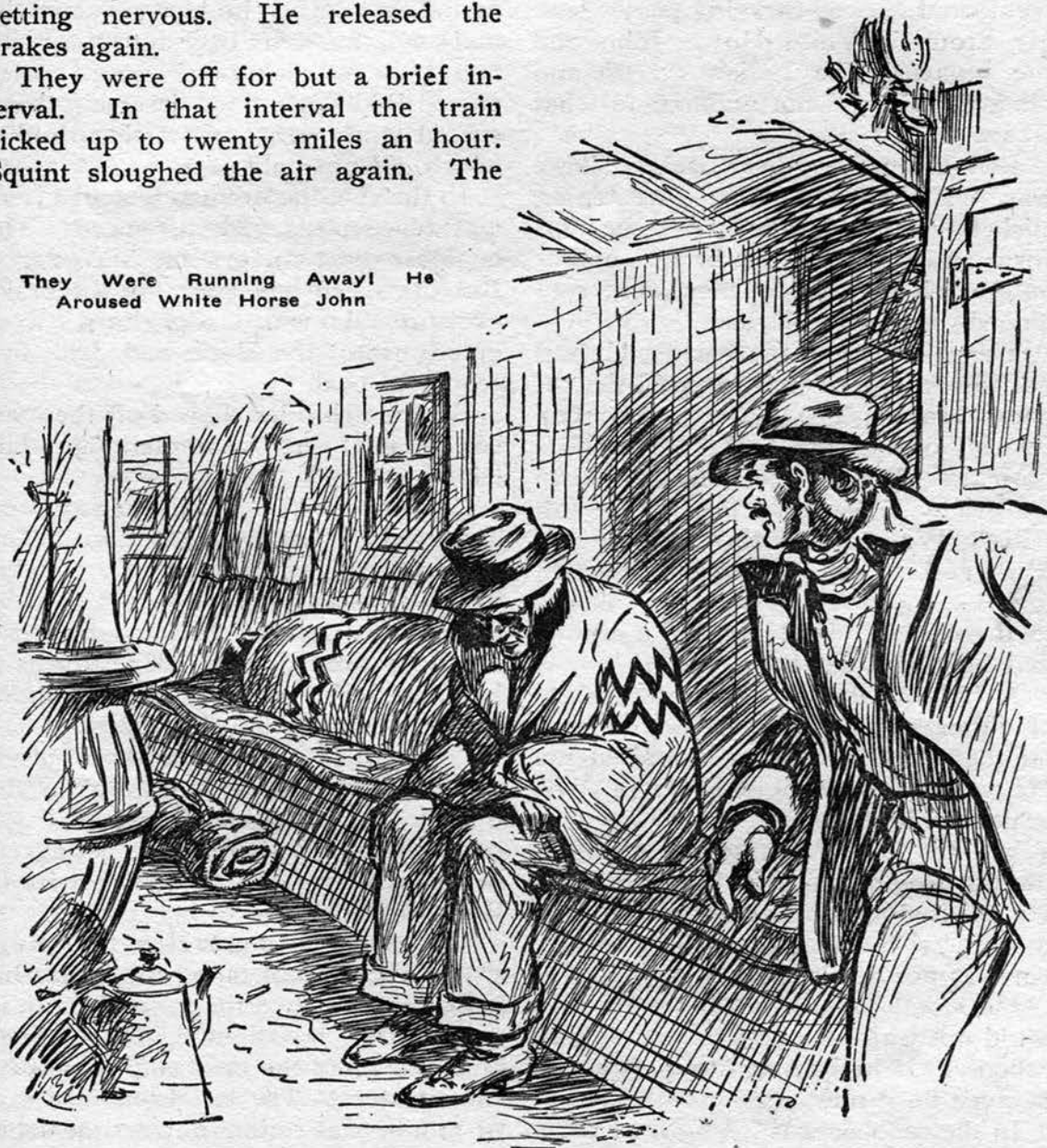

Squint re-crossed the cab, grabbed his whistle and began calling for brakes.

Back in the caboose, Red Waters had set the brake and viciously cursed the fool who would let a train get the edge on him on Glorieta on a night like this. He went inside and started out the front door, intending to go high and help the brakemen. Then he remembered he was carrying passengers. He aroused White Horse John and the squaw. The Indian sat up and blinked. He did not understand what was wrong.

Red listened to the wheels. There was no check to their threatening clickety-click. He returned to the platform and tightened the brake another notch. Now he knew they were running away down Glorieta.

Then he thought of a plan. He ran out the rear door and released the caboose brake. The wheels were free. Instead of holding back, the caboose now was shoving the runaway down the grade.

Red Waters ran through the caboose and out the front door. He tried to lift the pin which held the caboose to the car ahead. It was in a cramp, and he could not budge it.

A freight caboose had a brake wheel at either end. Red cracked his head on the front one when he raised up. He set his club into it and twisted. The brakes took hold. The slack went out. When the brake was set or released, the pin was clamped in the drawhead. He released the brake and tried to grab the pin when the slack was going in, but was not quick enough.

He stood looking down at it. He could not wait all night to cut off that caboose. If he intended to do it at all, he must do it now.

In the caboose was a length of wire.

He ran inside, jerked up the lid of the locker, brought out the wire, fashioned a hook out of it, wrapped the hook around the pin when the brake was set, held the wire in one hand and released the brake. The trick worked. The pin came out. The caboose was free from the train.

Red set the brake and stopped the caboose, but the train rolled down the mountain. The brakemen saw the marker lights drift back into the night and fade out behind a curve. They cursed Red Waters for deserting them, cursed and went on setting brakes which did not hold.

In the cab, the fireman watched trees and fence posts pick up speed. The engineer kept an eye on his gauges. But the speed had gone up, the brake pressure down. Longhorn went quietly into the deck and laid five scoops of coal.

Squint Schrader slipped off the seat-box. His knees were quaking. His teeth chattered.

"We're—we're runnin' away," he quavered.

Longhorn smiled grimly. "Are we?"

Squint staggered back to his seat. He did not remain in it. He came back into the deck. He grabbed Longhorn by the sleeve and cried frenziedly:

"We gotta jump man, we gotta git offa here! This outfit's goin' in the ditch. They're gone, Longhorn! All hell couldn't stop 'em. I'm gettin' off before it's too late. I've got a wife to think of!"

The engineer made for the gangway. He did not take time to get his grip. He watched the ground swim in under the headlight. When they emerged from the next cut, he was on the icy steps. The last Longhorn saw of him he was rolling into a snowdrift.

LONGHORN knew there was slim chance of stopping the drag now. It had too much headway. He watched the sparks moving atop cars where brakemen were at their posts, the fire flying from wheels, where brakes were burning them.

They crashed down Apache Canyon. On the left was the mountain wall. On the right was the canyon filled with snow. Ahead lay miles of frosted steel, and the curve and the cut above Canoncito. A sharp curve, and a deep cut, with a bridge beyond.

"There," thought Lannigan, "is the place this hog'll turn a handspring with forty freight cars after her."

Right—left, careened the engine, right—left—right. Her siderods flashed against the snow.

Her headlight threw shadows down the steel, and beyond the steel on the mountain wall. There in the night lay the curve, and the cut, and the bridge.

Longhorn pulled his head inside and closed the window. His left hand flipped the brake valve, released it to get a new grip. They were sliding again. He worked the reverse lever now. Flanges bit the frosted rail. They were running free.

There was a scream like the death cry of the damned. The engine lurched far to the right. Longhorn gripped his arm rest and applied the brakes.

Fire flowed from the wheels. The momentum was checked. They raced through Canoncito, streaked down the narrow valley.

The telegraph poles were swimming now, instead of leaping. The ties were no longer a blur. A white-faced brakeman slid into the deck and backed up to the firebox. He said, "I thought shore'n hell we was gone that time."

"We was," answered Longhorn, "but we come back."

The brakeman missed Squint. "Did the hoghead jump?" he queried.

"Nope," Longhorn flashed back. "He fell off."

"Yeah!" The brakeman tossed a couple of scoops of coal into the firebox. "The caboose fell off the hind end, too."

The two men laughed. Longhorn used his air once more and brought the engine to a perfect stop under the tank spout at Lamy.

THE crew deadheaded back to Las Vegas. Again the super held an investigation. Again Squint Schrader went in first. He tried to alibi.

"I have a wife," he said.

The official watched him coldly.

"There comes a time, Mr. Schrader, when an engineer must forget his wife, and remember only that he has duty. What other reasons have you? You must have let that train get the bulge on you."

"The track was slick," Squint said for the dozenth time. "The track was slick and the brakes refused to hold."

"But the fireman made them hold. There must have been some other reason."

"I guess I lost my head," admitted Squint.

"An engineer can never lose his head," the super told him. "This company needs men who *keep* their heads, and use them to think with."

Squint had no other alibi. The super told him he was through so far as running was concerned, suggested he might stay on firing if he so desired. And Squint stayed on.

Longhorn was the next upon the mat. The super did not ask him how the train had run away.

"Mr. Lannigan," he said instead, "your conduct last night deserves

commendation. Our records show that once you ran an engine here. The offence for which you were discharged has doubtless been atoned, and we need men like you. If you do not object, we'll mark you on the engineer's board, and let you go on running."

Longhorn's eyes glistened. He nodded his head and exclaimed, "Thank you, sir! I know of nothin' I'd like better!"

For many months Lannigan ran his engine off the extra board. He was the same old Longhorn, frolicking and pranking his way through life. Except that now he ran his engine by the book, no one would have thought that years had flown.

Squint Schrader fired a turn for Pop Wendell in the passenger pool. He grew morose and black and bitter. He whined and crabbed about his dirty deal, and blamed "Ol' Longhorn, damn him!" for his own demotion. He reasoned that had Longhorn jumped as he himself had done and let the train and engine take brakemen to their death in the cold of the mountain night, his own misjudgment might not have been discovered.

Meantime, A. Lincoln Terril made good in the West. Representatives of Boston capitalists saw possibilities in him. They took him from his humbler post and made him a king in the railroad world, a king on the lines of the Santa Fe.



#### The King and His Subject

ONE evening late in summer Lannigan was called for Pop Wendell's turn to take out the Pacific Express. He

met Squint at the engine. The fireman merely grunted, "Howdy."

Longhorn laughed and said, "I'm fine, ol' timer. How's the wife and how are you?"

Squint shrugged, made up his fire and stared gloomily over the yards.

When Longhorn backed into the standing train, he saw a familiar figure by the depot. It was a figure which had haunted his dreams for many moons—the slender, black-clad figure of A. Lincoln Terril, the new king of the road. Something made Longhorn's heart skip a beat or two.

Soon the trainmaster came bustling over.

"You've got a private car behind tonight, Lannigan," he said. "Mr. Terril and a party of high officials are riding. Don't shake 'em up too much."

Longhorn said, "All right. I'll handle 'em like they was settin' eggs that failed to hatch."

The superintendent was steering the party through the terminal. While the passengers ate, the brass hats went to the roundhouse and returned to the train. Before they reached the engine Terril said, "By the way, who's pulling us tonight?"

"A chap by the name of Lannigan," informed the super.

"Lannigan!" Terril didn't wobble a lash. He came down by the engine. Longhorn had finished oiling. He was standing beside the steps with the oilcan in the left hand, his gauntlets under his left arm, his red bandana flapping in the wind, and his right fist full of flimsies.

Terril stopped. Lannigan looked up. Except that years had deepened the sockets of his eyes, the king had not changed. He turned piercing eyes upon his serf.

"Are you back here running an en-

gine, Lannigan?" he asked incredulously.

"Yessir, Mr. Terril; you know what they say about plugged nickels an' wooden-legged chickens—"

The official cut in:

"I thought I fired you before I left here."

Longhorn fingered his watch. The Boston capitalists very discreetly turned their heads and began talking about New Mexico climate. The super lifted an uneasy voice.

"Lannigan came back to us quite a while ago, Mr. Terril. We hired him firing. We promoted him for an act of superior courage and cool-headedness. He is rapidly proving himself one of our most trustworthy and capable men."

Terril let out a snort and walked toward the rear. The matter would probably have ended there had it not been for the trouble two hours later.

**M**OUNTAIN railroading had always been hazardous. Ever since trains had been running, mechanical and human failures had brought them together in head-on or rear-end collisions whose disastrous results have been surpassed only by the terrible massacre of humans in automobile accidents today.

In order to prevent collision, to keep two trains from getting into the same territory at the same time, various devices had been invented. One of them, as nearly foolproof as anything before the modern automatic block and train control, was the "staff system."\*

Dangerous track (in this case only on the mountainous districts) was divided into convenient units or blocks. At each end of the block was a machine

constructed to hold a number of "staffs."

When the two machines governing a block were in "balance," there was a red signal at each end of the block, so that no train could enter it. A train coming to the one end of the block would call for the signal. The operator would then call the operator at the other end and ask for the staff. That operator would insert his key in his own machine, and the first operator then would remove *one* staff from his machine, and by running it through the "clearance box," clear the signal for the train to proceed.

As the train went by, the operator would hand the removed staff to the engineer. The engineer would carry it to the other end of the block and deliver it to the other operator, who would insert the staff in its proper groove, and the machines again would be "in balance," so that another staff could be removed from either one.

If anything happened to the staff, no train could proceed in either direction until the signal maintainer came and balanced the machines by transferring staffs from one to the other—except by going through a lot of red tape. For this reason, losing a staff was almost as serious as staging a head-on collision.

There was a staff block from Glorieta to Canoncito, and another from Canoncito to Lamy, each with its tower, staff machines and its operator.

**I**T was dark when they reached Glorieta. Longhorn came up the mountain whistling for the block. The operator called Canoncito and asked for the staff. Because the train was the Pacific Express, on time, and hauling royalty of the road, he got it without delay.

\*The staff system was installed on Glorieta in 1901.

He gave it to Longhorn on a contraption similar to the order hoop. Longhorn looped the hoop over the handle of his injector, where it could not fall off. He always put it there, because it was absolutely safe. The only way it could get off was for the engine to turn upside down or for someone to remove it.

The crew made the brake test. Longhorn started down the mountain on which not long ago he had won his promotion. When he made his first brake application going out of Glorieta, a brake hanger on the tank truck broke and dropped a brake beam. He stopped.

He did not look to see whether the staff was still on the injector handle. He lighted his torch, climbed out of the cab, crawled under the tank with some wrenches and a hammer to take off the beam.

Squint put in a light fire and went out to hold the torch for Longhorn. Soon the conductor, the porter, the super, and Terril came over to see what was causing the delay. They watched critically.

The engine began to pop. Lannigan had already mashed two fingers and caught an eyeful of iron rust. He was ready to explode. He bellowed:

"For gosh sake, Schrader! Get up there an' choke that damn thing off!"

Squint went into the cab. He had not mashed any fingers, but he had not forgotten that he had once run an engine. He was surly, and there was an angry flush on his smudged face. He went up the steps talking to himself.

"Ol' Longhorn, damn him! Thinks he's smart—bawling out at a guy like that when the brass hats is listenin'. I'll git even with him sometime."

He worked his injector to put cold water into the boiler. He opened the

door of the firebox to check the fire. As he raised up, he saw the staff hanging before him.

A cunning gleam came into his eyes. He did not take time to even think what he was doing, but acted from impulse. His little eyes darted over the cab, and his hand went up. When he left the cab the staff was not on the injector.

Longhorn removed the brakebeam, cut out the tank brake, and went on down the hill. He did not miss the staff until he was running into Canoncito.

Then he shouted across the cab: "Squint, have you seen that staff?" There was a tremor of uneasiness in his clear voice.

Squint started, answered, "Staff! Hell, no! Have you lost it?"

Longhorn made no accusations. The next block was cleared for him. The operator was trying to hand up the staff. Longhorn did not take it. He stopped even with the tower. The operator wanted to know what was holding him. Lannigan rummaged through his tool box, seat box, around the deck and platform. The staff was not there.

**B**Y this time lights were gleaming beside the train. Conductor, porter, super and Terril were coming. Longhorn crossed to the fireman's side again. Squint was rolling a cigarette. His hand was shaking. Longhorn grabbed him by the arm.

"Squint," he barked, "you threw that staff into the firebox."

"You're a damn liar!" the fireman shot back. "You lost it!"

Longhorn did not hit him, but removed his hand from the fireman's arm. "Don't try to fool me, Schrader," he said. "I've known you too long."

Squint laughed harshly.

"Go tell that to Old Man Terril," he



taunted. "He'll believe you. He's a friend of yours."

"I don't take my dirty linen to any office to get it washed," the engineer said evenly. "I wash it myself. I'm goin' to start right here an' now."

Squint shot a glance at the coal pick hanging on the cab frame.

"Hogheads has fell out of winders for sayin' less than that to their firemen," he muttered.

"This hoghead won't, because in the first place this fireman ain't got the guts to push him, an' in the second, you know you've been told the truth."

Under the window lights were dancing. The conductor was demanding: "What on earth's wrong over here? What's the matter with you, Lannigan?"

The officials arrived. They were annoyed. Longhorn descended from his cab. The others gathered about him. Terril was getting madder every minute.

"I've lost the staff," Lannigan announced.

"Lost what?" Terril blew up.

"I said I'd lost the staff."

For once Longhorn did not know exactly what to do. There were too many brass hats present. He started toward the office, because since he had returned to work, the first thing he did when anything happened was to tell the dispatcher about it.

Terril stopped him.

"Wait a minute, Lannigan!" Longhorn recalled that tone. He had heard it only once, and that was the day Terril had fired him. "Is this some new kind of joke you've invented? You couldn't lose a thing as big as that staff without knowing it."

"Do you think I threw it away?" Lannigan asked.

"It would be just about like you,

Lannigan." Terril was fuming. "You think because you've got back on this job after I fired you off it, you're putting one over on the officials."

This was too much. Longhorn clenched two fists and bristled up to the man who had discharged him years ago and now threatened to have the process repeated.

"Mr. Terril," he said, "I've come back to this job and railroaded by the book. I've risked my neck trying to keep your infernal trains on the track and keep them on time. If you aim to rawhide me the rest of my life because you got it in for me years ago, you can take your damn job, and your damn railroad—"

He told Terril in words of one syllable what he could do with both job and railroad.

Four railroaders gasped. Never in their railroad experience had they heard a serf say such things to a king as Lannigan said to Terril.

The super turned to his superior.

"I'm sorry, Mr. Terril," he said. "I'll see after this immediately. I assure you that such insolence shall not remain unpunished."

Terril had no reply. He walked back to the rear.

**I**N the office the engineer wrote and signed two messages. The first informed the dispatcher that the staff received by him at Glorieta had been lost. The second read: "Hereby resign position as engineer, effective end of trip."

The superintendent was waiting for him when he came from the office.

"Lannigan, what happened to that staff?" he asked.

The engineer smiled bitterly. "How do I know, sir? I didn't swallow it. I didn't throw it out of the window. I didn't burn it."

The super considered that statement. Then he started toward the engine. Lannigan was beside him. When they were halfway there, the official stopped.

"Lannigan," he queried, "Why did you tear into Mr. Terril tonight?"

"I dunno, sir. I reckon I jist got steamed up an' had to pop off."

"Of course, you know the only thing I can do now is—"

"Fire me? I've saved you the trouble and remorse of havin' to do that. I jist got done resignin'."

"Quitting us right here?"

"Nope. Unless you fire me, and call another engineer to take this train on in, I'm running it to Albuquerque."

The super swallowed a lump in his throat. Despite popular belief, railway officials who handle men *successfully* are human. Superintendent George Fletcher handled them successfully.

Longhorn swung heavily into his cab. Squint was whistling. He did not look around, and Longhorn did not speak. The engineer slipped into his place and the Express left Canoncito.

While the argument had gone on, the local freight had stopped at the Cerillos platform. Los Cerillos was a coal mining town eighteen miles below Lamy. Its merchants did a thriving business, and local freight for it was heavy.

The local crew unloaded a couple of tons of merchandise and twenty barrels of kerosene that night. Juan Lopez, who drove a span of gray mules to a dray wagon, commenced hauling it away.

Because the local was behind time, and because there was no "Rule G" on the dray wagon, Juan was in a bad humor. He loaded the first lot of merchandise, and dark though it was, crossed the tracks and left it in its owner's warehouse. He drove the

wagon over the tracks, and loaded the bed full of kerosene barrels.

LONGHORN left Canoncito making Lup time. Back in the private car, however, Terril was not talkative. He did not speak to the Boston capitalists, who quit asking what was the matter with the railroad and began wondering what had built a fire under this engineer and started him whipping the train around curves at a forty-mile clip.

When they were halfway to Lamy, Terril went to sit beside the superintendent.

"Did Lannigan find his staff?" he asked significantly.

"No sir!"

"What do you suppose he did with it?"

"I don't suppose *he* did anything with it."

Forty telegraph poles strode through the light shining from the car window. Briefly Fletcher sketched the incidents which had led to Lannigan's promotion. "Schrader," he added, "has always resented Lannigan. He is firing the engine tonight."

Terril nodded. "Why don't you ask Lannigan?"

"If Lannigan knows, he'll never tell."

Terril shook his head. "No. That's the trouble with that nut."

The whistle was blowing for Lamy. The two officials arose and started to the platform. "Lannigan wired his resignation from Canoncito," informed the super. "Says he's done railroad-ing."

Terril said nothing. He looked at Fletcher and a gleam came into his hard eyes. At Lamy he left the car and started toward the engine. One of the Boston men called to him. He turned back in answer to the call.

While he talked to them he looked at the flaring torch over by the engine where Longhorn was oiling.

While the crew took water the yard goat cut three Pullman cars in ahead of the private car on the rear of the train. They were loaded with "big bugs" who had come in off the Santa Fe branch from a sight-seeing trip in the ancient capital. The extra cars made the train an unusually long one.

Longhorn lost no time getting out of the Lamy yard. He moved quickly down the grade toward Cerillos. Before he was out of sight of green switchlights he had the varnish whipping along at a thirty-mile clip. That was not fast. The track was solid, and the brakes were good.

He kept thinking bitterly that this was his last trip on the Santa Fe. Inwardly he cursed Squint Schrader for trying to frame him. He cursed A. Lincoln Terril for a hard-headed fool. Then he cursed himself for letting his tongue break loose and talk him out of a good job.

He whistled for the milepost for Los Cerillos, looked at his watch, reached for the whistle cord, and held it down long and viciously.

Los Cerillos was a flagstop for the Express. When there were passengers for the west the operator signaled with a lantern. When the conductor had passengers to unload, he signaled with the cord.

Tonight there were neither. Longhorn watched. The order board was red. The operator came out with a white lantern. He gave Longhorn a highball, a signal that he was to go through and catch the order on the run.

**J**UDGING he was running a trifle fast for the fireman to pick up the order, Longhorn used his brakes. He

cut his speed. Without a word, Squint crossed the deck and went down the step to grab the order. Longhorn was watching the track. It was clear. He kicked off the brakes and notched the throttle. Then he leaned out of the window to watch Squint. The fireman was on the bottom step holding to the grabiron with his left hand, and his right outstretched to scoop up the order.

The engineer did not have his eyes off the track for more than a few seconds, but during that few seconds a change had come. A team of white mules pulling a dray wagon had swung in from behind the building and started over the crossing.

Longhorn grabbed for the whistle. Instinctively he yelled, "Look out, Squint!" Instinctively, also, he flipped the wrist of his hand on the brake valve.

In the wagon Juan Lopez lashed white mules. They jumped and jerked the wagon into the track. Juan was making the sign of the cross and muttering.

Then he and his helper left the wagon in a headlong plunge. They struck in the cinders but did not get up.

Barrels filled with kerosene hurtled into the pilot and the smoke box. Wooden staves cracked like match sticks. The oil swished back over the engine, rained through the cab windows.

It did not wet Squint Schrader because Squint, instead of grabbing the order, jumped off the engine and rolled into the depot.

There came an explosive puff. Fumes from the liquid reached the fire-box. The mass ignited. As the cab went over the crossing, a terrific burst of fire came up from the ground, threatening to lick up the wooden



Lannigan Stumbled Into the Gangway. Burning Gas Scorched His Lungs and Choked Him

coaches as they pushed ahead into it.

Instantly, from pilot to tail hose, the engine was a mass of billowing, roaring red with black smoke pouring from it. Lannigan's clothing was afire. Already he had set the brakes. What more could any engineer do?

He reeled back from his window, and stumbled into the gangway, struggled to get down the steps.

Before he reached the gangway, a thought flashed into his scorched brain. With the brakes set, the train was coming quickly to a stop. Before the last car had run by the crossing, it would cease to move. It would halt squarely in that pool of liquid hell. Those wooden cars would catch on fire. Before their occupants could get out they would burn.

**L**ANNIGAN turned back from the gangway. He groped for his platform. In that cab filled with fire and smoke he could see nothing. Burning gas scorched his lungs and choked him.

But his hand found the brake valve. It was burning hot. He flipped it to release. He found the throttle and opened it. The brakes came off. The exhaust barked; speed picked up.

Sounds grew dull, and everything began fading into distance. Even the pain was fading. The light was gone. In the darkness his fumbling hand moved, unconsciously working with the brakes. The train came to a stop.

The last wheel rolled through the fiery crossing. From coaches, from sleepers, from the private car, passengers came stumbling. Officials piled off the rear platform and ran back to the crossing.

A. Lincoln Terril, hatless, coatless, was in the lead. He watched blazes shooting higher than the housetops. He watched figures running around it.

He saw Squint Schrader. He did not see the familiar figure of Lannigan.

The official ran to the fireman and grabbed him by the arm. "Where's your engineer?" he shouted.

"I dunno!" Squint groaned. "I guess he's still in the engine."

Terril turned the fireman loose. He shot one quick look toward the engine. Occasional bursts of flames were still whipping from pilot or gangway. He called to the excited superintendent, "Come on, George. We've got to go find Lannigan. He's on the engine."

They found him. He lay where he had plunged out of the gangway.

FOR months Longhorn Lannigan was swathed in bandages. There was a question whether or not he would live, and then whether or not he would see. Finally came the day when the test was to be made in the Topeka hospital.

"It would be a damned shame," Terril said huskily to his wife that morning, "if that boy should come out

of this blind. He's the kind of man this railroad needs."

Dead quiet reigned in the darkened room where the test was to be made. A. Lincoln Terril and a superintendent named George Fletcher were there. When the bandage came off, Longhorn blinked into the subdued light.

"What do you see, Lannigan?" queried one of the doctors.

"I—ain't right shore, doc," Longhorn drawled. "Maybe I'm jist dreamin', but it seems to me I see ol' Terril standing back there by the door."

A. Lincoln Terril burst out with a merry laugh and came striding forward.

"You ornery cuss!" he was barking joyously, "Are you right sure it ain't a longhorn bull givin' you a highball? Or a couple of good looking dames wantin' to ride in Vegas?"

And when Longhorn, new bandages hiding the world he longed to see, returned to await patiently until his eyes grew strong, he knew he had found a friend in the man who had tamed him.

## Does France Have Fastest Long-Distance Train?

THE Sud (South) Express of the Paris-Orleans-Midi Railways of France is said to be the first and only regularly scheduled steam train to travel more than 300 miles at an average speed of over 60 miles per hour including stops, thus giving it the distinction of being the world's fastest. This express recently has been scheduled to run 362 miles between Paris and Bordeaux in 355 minutes, with only 4 stops en route. The stretch between Poitiers and Angoulême has a time card calling for a 70-mile run in 60 minutes—which is said to be the first 70 m.p.h. run on a regular French schedule.

Other French trains also are going in for higher speed. For instance, the 219-mile non-stop run between Nancy and Paris, on the Est, is now being made in 216 minutes. It is the first time in which a French train has been carded at more than 60 miles an hour for a non-stop run exceeding 200 miles.

In Great Britain the L. N. E. R. London-Edinburgh "Flying Scotsman" is a strong contender for long-distance speed honors, as was the Great Western's "Cornish Riviera" until its time was beaten by the "Scotsman." Several American trains also claim the title.

In Germany the "Flying Hamburger" made a trial run of 357 miles between Berlin and Cologne in 4½ hours, an average of 79 m.p.h. Actual traveling speed was 74½ m.p.h. and highest speed reached was 99½. This was exceeded in America by the Union Pacific streamlined M-10001, which recently ran 2298 miles between Los Angeles and Chicago in 39 hours, at an average of about 60 m.p.h., attaining a speed of 120 over short stretches. However, these two were only trial runs.

By the  
Light of  
the Lantern



Ask us  
what you  
want to know

**R**AILROAD questions are answered here without charge, but these rules must be observed:

- (1) Not more than two questions at a time. No queries about employment.
- (2) Always enclose a self-addressed, stamped envelope, to facilitate our getting in touch with you if necessary. We will print only your initials.
- (3) Don't be disappointed if answers do not appear at once. They are printed two months before date of issue.

**N**EWSPAPER reports of the Canadian National wreck last Christmas night at Dundas, Ont., state the engineer of the speeding express train, when he saw the sidetracked excursion train ahead of him and the open siding switch, uncoupled his train from his engine. It sailed into the excursion train, and killed 15 excursionists, whereas his coaches lost momentum and came to a stop with only a slight jar and hardly a bruised passenger. Tell us, how could this happen?—V. W., Toronto; J. D., Chicago; E. R., Erie, Pa.

Gentlemen, this is a new one in the annals of railroading. Some of the deeds the old-timers brag about in the Boomers' Corner pale in comparison with this feat. Save your clippings on this wreck and show them to your grandchildren and tell them how they used to railroad 'way back in '34, when hoppers not only were heroes, but supermen to boot. Fooling aside, if you want to play fair with the hoppers, you'll tell the kids that most newspaper reporters never did know anything about railroading, that what they wrote looked good to them, and that what finally appeared in the papers looked good to most of the people who saw it—with the exception of informed readers such as yourself.

**H**OW does the Joy valve gear work? The Good gear?

(2) How is the tractive force of a two-cylinder simple locomotive figured? Two-cylinder com-

pond? Three-cylinder simple and compound? Four-cylinder simple and compound?—J. G., Evanston, Ill.

(1) Diagram and explanation of Joy valve gear on p. 83. We don't know anything about a so-called "Good" gear. Probably it was one of the hundreds of "ideal" valve gears which never got to first base.

(2) The following formulæ are standard, assuming 90% maximum cutoff. In them C represents the diameter of simple cylinder (in.); c the diameter of the low pressure cylinder (in.); S the stroke (in.); P the boiler pressure (lbs.); D the diameter of the drivers (in.).

The formula for a two-cylinder simple engine is

$$T.f. = \frac{.85 P \times C^2 \times S}{D}$$

For a three-cylinder simple engine:

$$T.f. = \frac{.85 P \times C^2 \times S}{D} + \frac{.85 P \times A^2 \times B}{2D}$$

(A represents diameter and B the stroke of inside cylinder.)

For a four-cylinder simple engine (articulated or otherwise):

$$T.f. = \frac{1.7 P \times C^2 \times S}{D}$$

For a four-cylinder compound (Mallet):

(C is diameter of high pressure cylinders.)

$$T.f. = \frac{1.7 P \times c^2 \times S}{\left(\frac{c^2}{C^2} + 1\right) D}$$

These formulæ are not hard to work out; in past issues we showed how to use them, and cannot devote space to a demonstration now. In case the engines are equipped with 50% cutoff and auxiliary ports with 80% cutoff, substitute .75 for .85 and 1.5 for 1.7 where appropriate. Formulæ for three-cylinder compounds (rare in America), and two-cylinder compounds (practically extinct),

are not standardized, and vary so greatly that it would be useless to print them here. Refer to any older locomotive textbook at a good library for them.

**S.** F. and L. E. J., Columbus, Ga.—See above for t.f. formulæ.

**H**OW thick is the boiler plate on the average modern locomotive?

(2) What do you think are the fastest 4-6-2, 4-6-4, 4-8-2 and 4-8-4 types in America?—H. W., Pensacola, Fla.

(1) Depends on the size and type. The average 4-8-2, 4-6-2, etc., use boiler steel of various thicknesses: 13/16 in. for the first and second courses; 7/8 in. for the conical course; 3/4 in. for the throat sheet; 3/8 in. for the crown-sheet; and 1 1/16 in. for the combustion chamber course.

(2) There are too many factors in this question to give you an answer which is both valid and specific. The best we can do is to look at specifications, note well items such as boiler capacity, and make a few broad statements. Doing this, we find that any 4-6-2 type with 79 or 80 in. drivers is constructed so that it is probably equal to any other of the group under the same conditions, assuming, of course, it is not overloaded. Among such engines are Pacific types on the PRR, NYC, B&O, Reading, CRRofNJ, DL&W, the new B&M engines (photo to right), the rebuilt C&NW Class E-2a (p. 84), and others with similarly balanced dimensions.

Among the 4-6-4 types, again those with 79 or 80-in. drivers would take the prize for speed. Of this group, those on the NYC, CNR, and Milwaukee (see "85 Miles in 67 Mins.," Nov., 1934) stand out, with the Burlington 3000 series, which is larger and heavier but which has only 78-in. drivers, pressing close.

Undoubtedly the speediest of the 4-8-4 types is the 2575 series of the Great Northern, which has 80 in. drivers, fairly short piston stroke, and large boiler capacity. Next come the various 4-8-4's with more than 75-in. drivers, such as those of the Lackawanna, LV (p. 90), NP (see p. 137, Feb., 1935), and C&NW (pp. 87, 89, Dec., 1934).

It is a harder job to find outstanding examples of 4-8-2 types which are as swift. Few have drivers of more than 73 in. The largest is 74 in., on Mountain types of the B&O, CB&Q and Rock Island, all of which are equally fast.

**D.** M., Marshalltown, Iowa.—The Burlington does not operate regular freight service from Galesburg to Savanna via Clinton and Rock Island, but via Barstow, Denrock, and Oliver, on which line Class O-1a Mikados (Trains 96 and 97) have 4,500-ton rating, and Class O-3 Mikados (Trains 77 and 80) 5,500 tons. The ruling grade in both directions is 1.17%. If freight trains were run via Rock Island and Clinton, the engine ratings would be about the same.

**W**HY are some PRR Class K-4s engines equipped with flanged center drivers, while others are blind?—O. F. D., Washington, D. C.

Formerly almost every PRR Pacific type had blind tires on the center drivers. However, many trials have shown that flanged tires on all driving wheels resulted in

This is the First of Five High-Speed "Streamlined" Pacific Types (Class P-4a) Recently Built by Lima for the Boston & Maine. They Have 23 x 28 Cylinders, 80 In. Drivers, 260 Lbs. Pressure, Weigh 339,200 Lbs. without Tender, Exert 40,900 Lbs. T.F.—with Booster, 52,800 Lbs. Note the Smoke Lifters on Each Side of the Front End

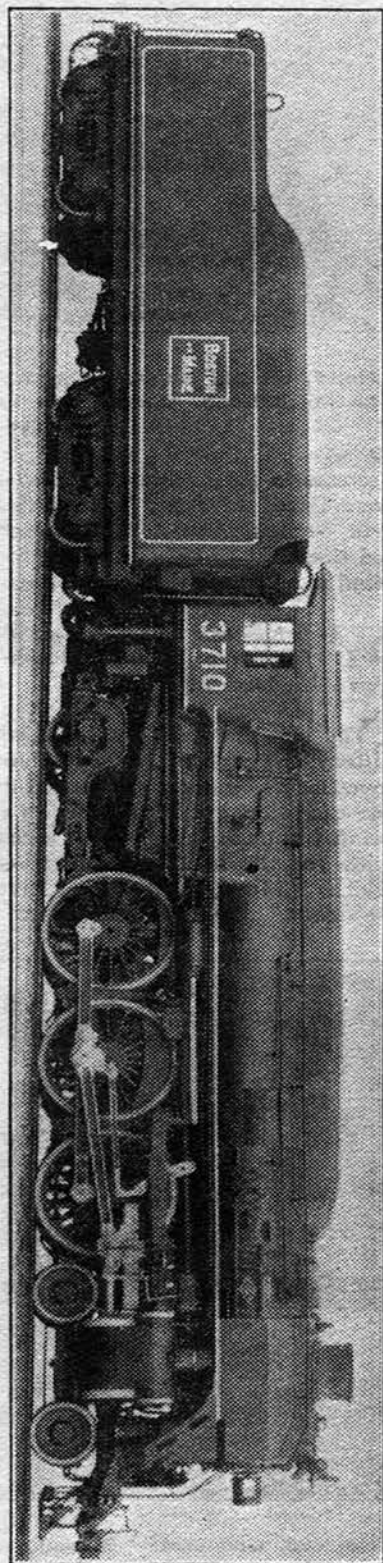



*Photo by W. R. Osborne, 38 Colonial Ave., Whitehorse, Trenton, N. J.*

No. 7, an Old Baldwin Eight-Wheeler of the Union Transportation Co., Which, Though Only 25 Miles Long, Operates in Four New Jersey Counties: Burlington, Ocean, Monmouth, and Mercer. See Answer to W. C. N. for History

decrease in flange wear, and last July instructions were issued to apply flanged tires to all Pacific type engines when it became necessary to replace old tires. At present, however, more Pacifics have blind main driver tires than flanged tires.

**W**HERE can I get "straight" historical information about American railroads?—T. A. R., Decatur, Ill.

The best and most complete source of railroad history is Poor's or Moody's manuals of railroad investments. Poor's was started in 1860, and with the exception of a few years in the next 15 was printed annually until 1923, when it was merged with (or the name changed to—we don't know which) "Moody's Manual of Investments—Steam Railroads." Some of the older volumes include

even street car companies, and many run to more than 2,000 pages. Practically all good-sized newspapers and public libraries have them on file in their reference rooms.

**E.** L., Villa Park, Ill.—According to C. C. Madison and A. G. Hale, the Chicago Great Western had two series of Mallets: Nos. 650-652, 2-6-6-2 type, built at Oelwein, Iowa, in 1910, from older Prairie types. They had 21 & 35 x 28 cylinders, 63-in. drivers, 200 lbs. pressure, weighed 315,000 lbs. without tender, exerted 52,100 lbs. t.f. Photo below. No great successes, they were finally scrapped. The other series, same type, were built by Baldwin in 1909, numbered 600-609, had 23 & 35 x 32 cylinders, 57-in. drivers, 205 lbs. pressure, weighed 353,100 lbs. without tender, exerted 81,175 lbs. t.f. They were sold to the



*From G. B. Stuart, N. P. Agent, Burt, N. Dak.*

No. 652, One of the Chicago Great Western's Old Mallets, Hauling a Freight Train through Dyersville, Iowa, 23 or 24 Years ago. See Answer to E. L. for Data



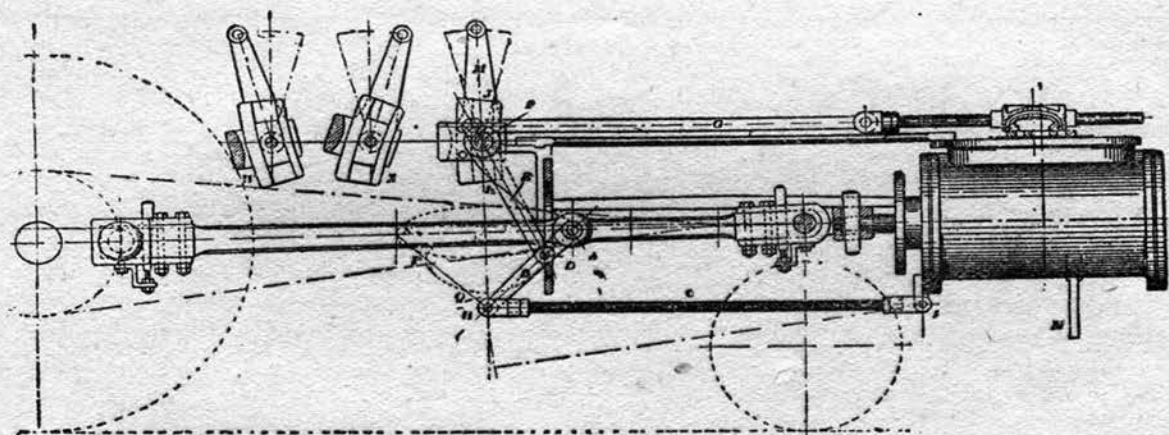

The Joy Valve Gear, Perfected in 1879 by an Englishman Named David Joy. Lever E is Connected to the Vibrating Link B, and Thus Transmits Movement to Valve Rod G. The Fulcrum (F) of Rod E is Carried Vertically in Blocks Which Slide in Slots in the Links (JK). The Engine is Reversed by Moving the Valve Slide. Though the Joy Gear Was Fairly Popular in England, It Was Installed on Only a Few American Engines

Clinchfield RR, in whose roster they were M-3 and later M-1. One of them, renumbered 500, was in the list of Clinchfield locomotives printed in our Jan., 1934, issue.

**D. A.**, Baltimore, Md.—The Maryland, Delaware & Virginia Ry. got its start as the Queen Anne's RR, chartered in 1894-1895, and opened in 1898. As the MD&Va it ran from Love Pt., Md., to Lewes Pier, Del., and its total mileage was 83. In 1915 it had 11 locomotives, 27 passenger, 39 freight cars and 10 steamships. In 1923 it was sold at auction and partly acquired by a corporation called the Baltimore & Eastern, in reality a subsidiary of PRR. The Baltimore & Eastern still operates a part of the old MD&Va, and at present has 125 miles of track. Its main line runs between Love Pt. and Oxford, Md. The part of the old MD&Va between W. Denton, Md., and Lewes, Del., is now the Maryland & Delaware Seacoast.

**B. W.**—The Camino, Placerville & Lake Tahoe RR was incorporated in 1911 as a successor to the Placerville & Lake Tahoe, which was sold at auction. It runs from Placerville to Camino, Calif., 8 miles, has 1 locomotive, 1 freight car and (a year ago) 10 employees. It has been losing money during the last few years.

(2) The Diamond & Caldor was built about 20 years ago as a lumber road. It runs between Diamond Springs and Caldor, Calif., 33 miles, is 3 ft. gage, has 8 locos, 120 cars, is controlled by the Calif. Door Co.

**W. C. M.**, Philadelphia.—The Union Transportation Co. is still operating between Pemberton and Hightstown, N. J., 25 miles. It

was incorporated in 1888 when it leased the Pemberton & Hightstown. The PRR pays maintenance on that part of its line between Lewistown and Pemberton, 3 miles. Although its operating income lately has not been enough to pay for operating expenses, its non-operating income has kept it out of the red every year except 1930. It has 2 locomotives, 7 cars, and a year ago employed 11 people. We are printing herewith photo of its No. 7, 4-4-0 type.

**O. O.**, Bronx, N. Y.—Four railroads operate on the Hawaiian Islands, of which the principal one is the Oahu, for information about which see "A Mid-Ocean Railway," in next issue. Another is located on the island of Kauai, another on Hawaii and a very short line on Maui.

**B. C. N.**; J. W.—Illustrated item on all classes of SP articulated (Mallet) types will appear in near future.

**J. A. C.**, Chicago.—The Kanawha, Glen Jean & Eastern was incorporated in 1895, runs between Glen Jean and Tamroy, W. Va., 8 miles, with a branch from Sugar Creek Jct. to Pax; total mileage, 15. It has 3 locomotives, 204 cars and (a year ago) 47 employees. It has not earned expenses the last few years. Road and equipment are valued at \$1,251,392; total assets are \$1,754,902.

(2) Information on Davenport Loco. Works in near future.

**W. V. R.**—Following are steam roads operating in Delaware: Baltimore & Ohio, Md. & Del. Seacoast, PRR.

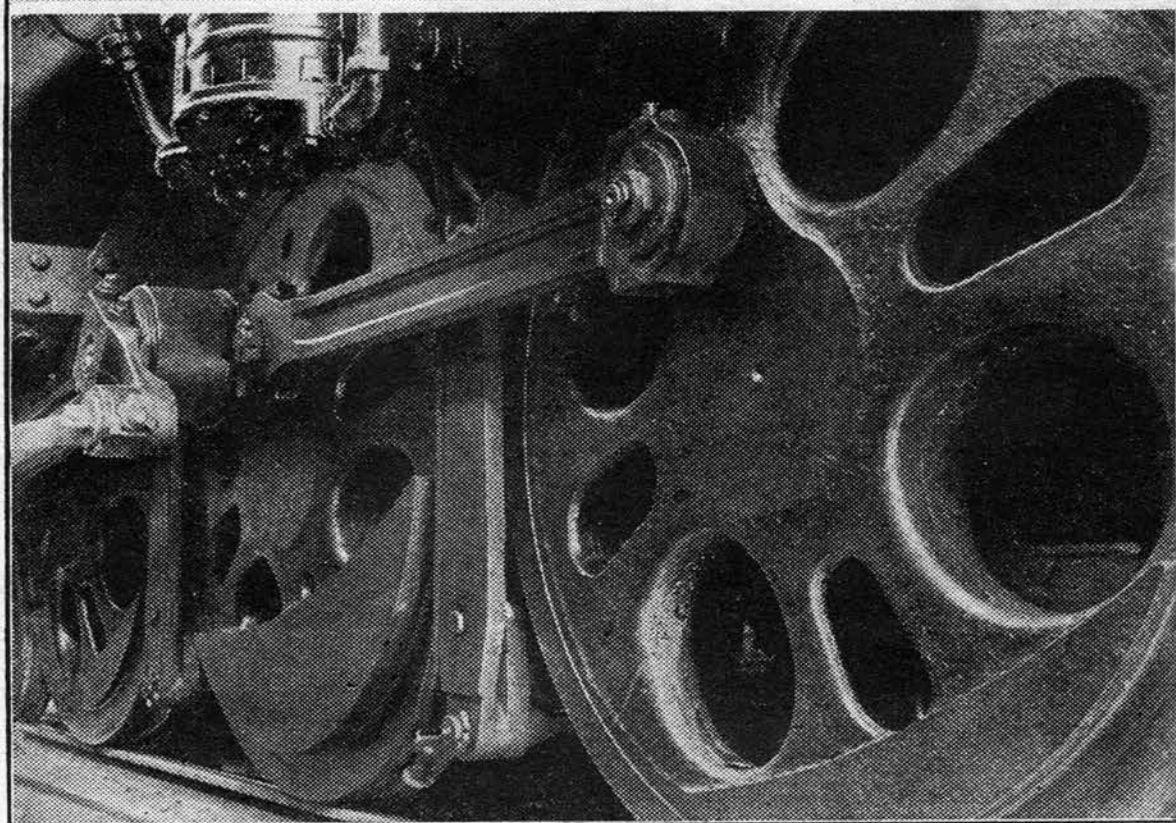
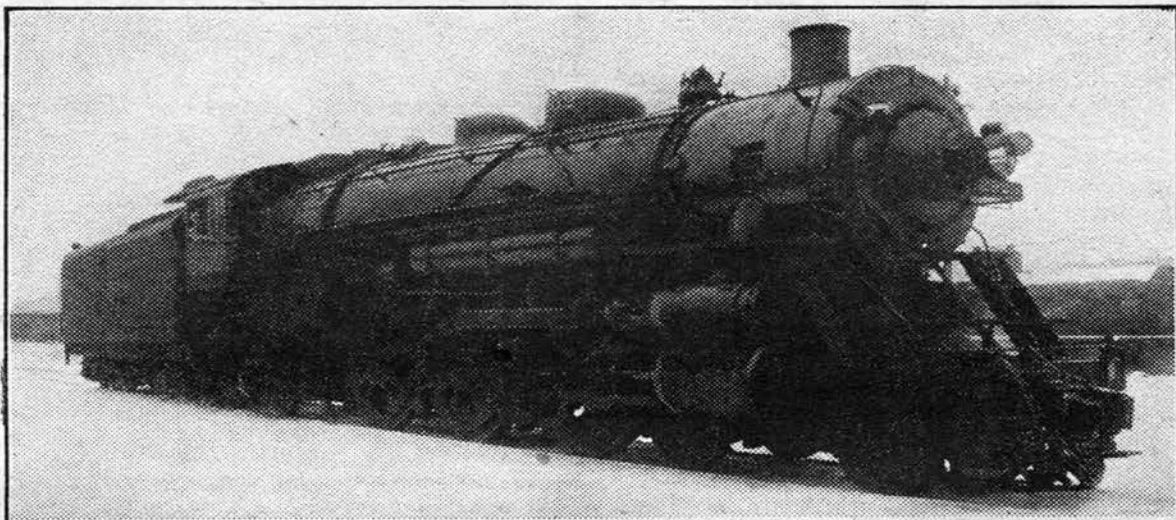

Take a Good Look at the Speed Queen of American Rails! She's One of the New Gals Who Got the Jump on the Gas Buggies by Dally Hauling the Chicago & North Western's "400" between Chicago and the Twin Cities, 411 Miles in 7 Hours Flat. Notice Her New Disc-Type, 79-In. Drivers, Which Enable Her to Hit 95 Miles an Hour "with the Greatest of Ease," and Which Can Carry Her over a Hundred. Read More about Her and Her Sisters on Page 87

**W**HAT is meant by (1) pulling up the reverse lever, (2) dropping it down to the last notch, and (3) down in the corner?—H. S., Oconomowoc, Wis.

The reverse lever does not only change the direction of movement by shifting the valves, but at the same time regulates the amount of steam entering the cylinders. When a locomotive is

Starting or traveling at slow speed upgrade with a load, more steam must be admitted to the cylinders than is either possible or necessary at higher speeds. This means the valve admitting steam to the working end of the cylinder must stay open longer during the piston stroke. Hence the engineer increases the valve "travel" by pushing the reverse lever down toward the end or to the end of the quadrant (the notched piece of metal on which the reverse lever moves). As soon as the load is under way less steam is needed, and the reverse lever is adjusted toward the center of the quadrant. In fact, this must be done to attain any speed, for as the pistons move faster the boiler cannot take care of their demand for steam unless not so much is admitted to the cylinders. Moreover, when less is admitted, more use is made of steam's expansive power, and thus the locomotive operates more efficiently. In your question, then, Nos. 2 and 3 mean practically the same thing, and No. 1 designates the act of decreasing the amount of steam entering the cylinders by hooking the reverse lever "up toward center."



**L.** G., Everett, Wash.—Although some people in your part of the country claim the Hartford Eastern Ry. (in Wash.) has the sharpest standard gage curve in the country, the claim should be taken with more than a grain of salt. The only way to make sure would be to compile a list of all standard gage curves in the country. Nobody, so far, has undertaken this job.

(2) The following steam roads operate in Wisconsin:

Ahnapee & Western  
 Cazenovia Southern  
 Chicago & North Western (incl. CStPM&O)  
 Burlington  
 Milwaukee Road  
 Duluth, Missabe & Northern  
 Duluth, South Shore & Atlantic  
 Ettrick  
 Great Northern  
 Green Bay & Western  
 Hillsboro & Northeastern  
 Illinois Central  
 Kewaunee, Green Bay & Western  
 Laona & Northern  
 Marinette, Tomahawk & Western  
 Soo Line  
 Northern Pacific  
 Robbins  
 Wisconsin & Michigan



**R.** M. H., Brainerd, Minn.—The Minnesota & International Ry. (now controlled by NP) was incorporated in 1900, absorbed the Brainerd & Northern Minn. in 1901. The Northome to Big Falls Line was built as the Big Fork & Northern Ry., but leased in 1905 by the M&I, which now runs from Brainerd to Northome, with a

branch to Kelliher, Minn. It has 180 miles of main line, 9 locomotives, 6 pass. and 466 freight cars. It operated at a loss in 1933, 1931, 1929, 1928.

(2) The following steam roads operate in Georgia:

Ala. Great Southern (Southern)  
 Atlanta & West Point  
 Atlanta, Birmingham & Coast  
 Atlanta, Stone Mountain & Lithonia  
 Atlantic Coast Line  
 Bowdon  
 Central of Georgia  
 Charleston & Western Carolina  
 Chattahoochee Valley  
 Collins & Glenville  
 Flint River & Northeastern  
 Gainesville Midland  
 Georgia  
 Georgia & Florida  
 Georgia, Ashburn, Sylvester & Camilla  
 Georgia Northern  
 Georgia, Southwestern & Gulf  
 Greene County  
 Hartwell  
 Lakeland  
 Louisville & Nashville  
 Louisville & Wadley  
 Macon, Dublin & Savannah  
 Milstead  
 Nashville, Chattanooga & St. Louis  
 Sandersville  
 Savannah & Atlanta  
 Seaboard Air Line  
 Shearwood  
 Southern  
 South Georgia  
 Sylvania Central  
 Talbotton  
 Tenn., Ala. & Georgia  
 Wadley Southern  
 Wrightsville & Tennille



**X.** Y.—According to C. H. Brady, Secretary to the Gen. Pass. Agent of the Burlington, the Aurora, Plainfield & Joliet was a 22-mi. long trolley line extending from Aurora to Joliet, Ill., and was abandoned sometime before 1926. The car barn at Plainfield is still standing, but is now used as a garage by the bus line which supplanted the cars. Further information can be obtained from Lutz White, Historical Editor, Aurora "Beacon News," Aurora, Ill.



**A.** P.—The only information we have on Santa Fe 260 is that she was probably similar to the present 261 series, of which Nos. 274, 276 and 279 are left. They are 4-6-0 type, have 18 x 26 cylinders, 150 lbs. pressure, 58-in. drivers, weigh 113,750 lbs., exert 18,500 lbs. t.f.

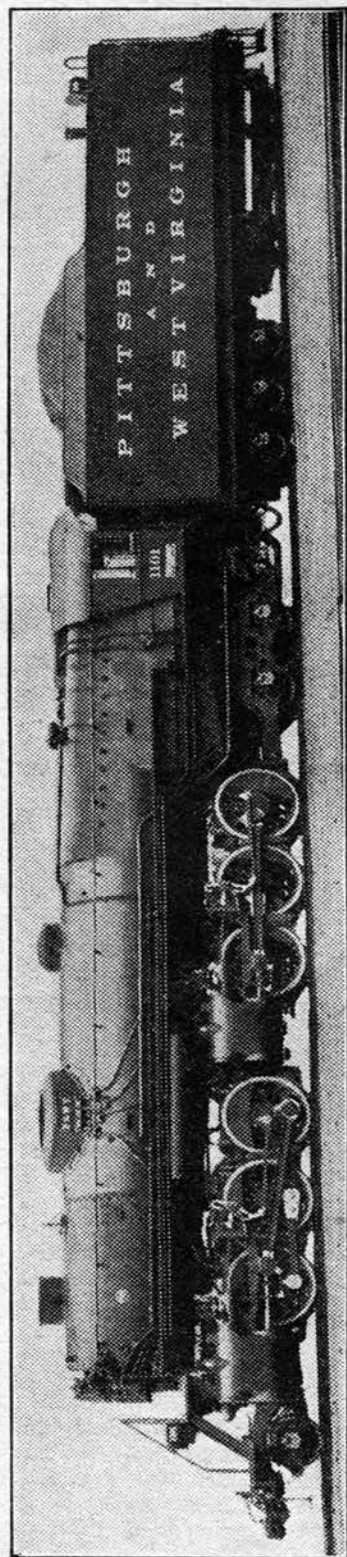

One of the Three New Articulated Engines (Nos. 1100-1102) Built Last Fall by Baldwin for the P. & W. Va., Which Usher in a New Wheel Arrangement, the 2-6-6-4. They Have 23 x 32 Cylinders, 63-in. Drivers, 225 Lbs. Pressure, Weigh 528,040 Lbs. without Tender (905,640 with), Exert 97,500 Lbs. T.F.—113,500 Lbs. with Tender Booster. They Cost \$110,500 Each

**S. M. C.**—The Boston & Albany was incorporated in 1870 as a consolidation of several lines: the old B&A, the Albany & W. Stockbridge, and the Hudson & Boston Corp. In 1880 it took over the Springfield & Northwestern; in 1889 the Spencer RR. In 1899 it was leased to the NYC&H, and was consolidated into the NYC system in 1900.

**R. W.**, Islip, N. Y.—At present four or possibly five railroads operate in Alaska: the U. S. Govt.-controlled Alaska RR, the Copper River & Northwestern, the White Pass & Yukon, the Yakutat & Southern and maybe the Thane Perseverance. We have no up-to-date information on the last one. For information about railroads which have operated in Alaska see p. 134, May, 1933, issue.

(2) The Northern Alberta Ry. was incorporated in 1929 by the CNR and CPR, which own it jointly, as a merger of the Alberta & Great Waterways Ry., the Edmonton, Dunvegan & British Columbia Ry., the Pembina Valley Ry. and the Central Canada Ry., all owned by the Province of Alberta. The A&GW had been incorporated in 1909 to build from Edmonton to Lac la Biche; and the ED&BC had been incorporated in 1907 to build from Edmonton to Spirit River. Refer to map in any Canadian National system timetable for the layout of the Northern Alberta Ry.

**D. F.**, Auburn, N. Y.—The Hayes derail, manufactured by the Hayes Track Appliance Co., is a form of block derail used almost entirely on side tracks, to derail equipment moving in either direction. As you probably know, any block derail is anchored on the track, and when it is in position, lifts the flanges of one wheel over the rail and at the same time pulls the other off the rail.

**C. S.**—What is now the Bellevue & Cascade was built 55 years ago, and was operated until the summer of 1933 as a narrow gage branch of the Milwaukee Road. At the time it was being abandoned by the Milwaukee we printed a short article about it. However, a new corporation called the Bellevue & Cascade RR bought the old line and equipment, taking it over in August, 1933. Its four locomotives, 3 pass. and 110 freight cars, together with a snowplow, were purchased for \$17,000. Reports say that the line is doing well, but we have no figures on its income.

**C. G.**—The front end throttle is simply a throttle located in the front end or smoke box of a locomotive, rather than in the steam dome. Some are placed entirely within the front end; others are in a housing which sticks up either ahead of or behind the smoke stack. You can tell front-end throttles easily by noting the throttle lever along the engineer's side of the boiler.

(2) Low pressure cylinders of compound locomotives vary in size, depending on size and kind of locomotive. Thus it is impossible to tell you "how big the piston is in a low pressure cylinder." How high is a building?

**E. H. C.**, Los Angeles.—The "object ahead of the smoke-stack on Bangor & Aroostook No. 253" is the housing of the front end throttle. See answer to C. G.

(2) The rod connected to the pin of the rear driving wheel and running back under the cab of the old-time engine illustrated on p. 45 of our Feb., 1935, issue was the connecting

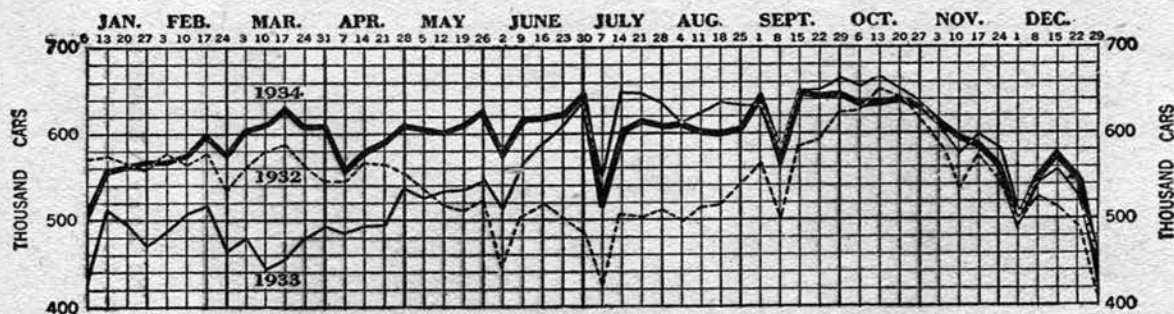

This Chart Tells How the U. S. Railroads Fared during the Last Three Years. The Three Irregular Horizontal Lines Represent the Number of Cars Loaded throughout Each Year. For Purposes of Comparison Weeks with National Holidays Are Made to Fall Together

rod for the water pump, which, of course, pumped water from the tender into the boiler. Other old-timers used a pump attached to the crosshead of the engine.

**W**HAT class engine is used on the C&NW's new "400" flyer between Chicago and the Twin Cities? Where are engines changed?—F. H. S.

Class E-2 Pacific type locomotives Nos. 2902, 2903, 2907, 2908 were rebuilt in the Chicago shops for this high speed service. Original specifications and photo appeared on pp. 87 and 89 of our Dec., 1934, issue. The rebuilt engines, designated Class E-2a, have same cylinders, 79-in. drivers (of new solid design), 225 lbs. pressure, 295,000 lbs. weight, and 45,800 lbs. t.f. The tenders are enlarged to hold 15,000 gals. water and 5,000 gals. oil. Oil is being used for fuel merely to eliminate operating stops, but the engines are changed at Milwaukee because a tank of it will not last all the way from Chicago to St. Paul. Scheduled stops are Milwaukee, Adams, Eau Claire, St. Paul, Minneapolis. C&NW engines haul the train clear through, do not give way to CStPM&O power at Elroy. (Photo on p. 83.)

The train covers 410.6 miles between St. Paul and Chicago in 7 hrs. flat, actually averaging 58.7 m.p.h. For purposes of advertising, however, the C&NW says it makes 400 miles in 400 minutes—which it does, if running time alone is considered. Originally the C&NW intended to haul 4 cars in the train, but now carries 6. On the first trip the train covered the 81 miles between Wyeville and Eau Claire in 67 mins., averaging 74 m.p.h., and hitting more than 90 m.p.h. at times.

The train is distinctly a triumph for both steam power and the C&NW, which despite the fact that it is purchasing neither steam nor Diesel streamlined trains, has got the jump on and is prepared to meet further competition of both the Burlington and the Milwaukee, who will make the run in 6½ hrs. as soon as their new trains are completed. The Burlington's trains will be Diesel-powered, similar to the famous "Zephyr"; the Milwaukee's

will use a light weight, streamlined steam locomotive. These trains should be ready about the time this issue comes out.

**E.** H. B., Roseland, N. J.—The Morristown & Erie RR was incorporated in 1903 as a consolidation of the Whippany River RR and the Whippany & Passaic River RR. It runs from Morristown to Essex Fells, N. J., 11 miles, and has a 2-mi. branch to Malapardis. It owns 3 locomotives, 12 cars, employs about 22 people, is valued at \$856,546, and has total assets of \$880,736. In 1933 net income was \$286; in 1932, \$9,463; 1931, \$24,617. Don't ask us why "the owners of the road (McEwan Bros. Paper Co.) ship their paper by truck." Maybe they want to do away with that net income item.

**C.** H. B., Chicago.—The maximum grade on the Lackawanna between Buffalo and New York is 1.69%, westbound between Mt. Pocono and Pocono Summit, Pa.

The maximum grade on the Lehigh Valley between New York and Buffalo is 1.19% westbound, east of Bear Creek Jct., and 1.81% eastbound from Warrior Run to Mountain Top. On the Ithaca branch the maximum grade is 1.32% westbound, just west of Ithaca; and 2% eastbound at W. Danby.

The maximum grade on the B&A between Albany and Boston is 1.72%, east of Palmer.

**R.** B., Toronto.—There is nothing unusual in NYC engines pulling its through N. Y.-Toronto trains from Buffalo over the TH&B and CP into Toronto. Many railroads operate their engines over the tracks of other lines under similar circumstances.

(2) The equipment of the old Canadian Northern, or what is left of it, is now owned by the Canadian National. We have no copy of its insignie, but if a reader will send us a suitable one we shall try to print it sometime.

A gas car such as that used by the CNR on its Hamilton-Allandale line has a maximum speed of about 70 m.p.h.

## Locomotives of the Lehigh Valley Railroad

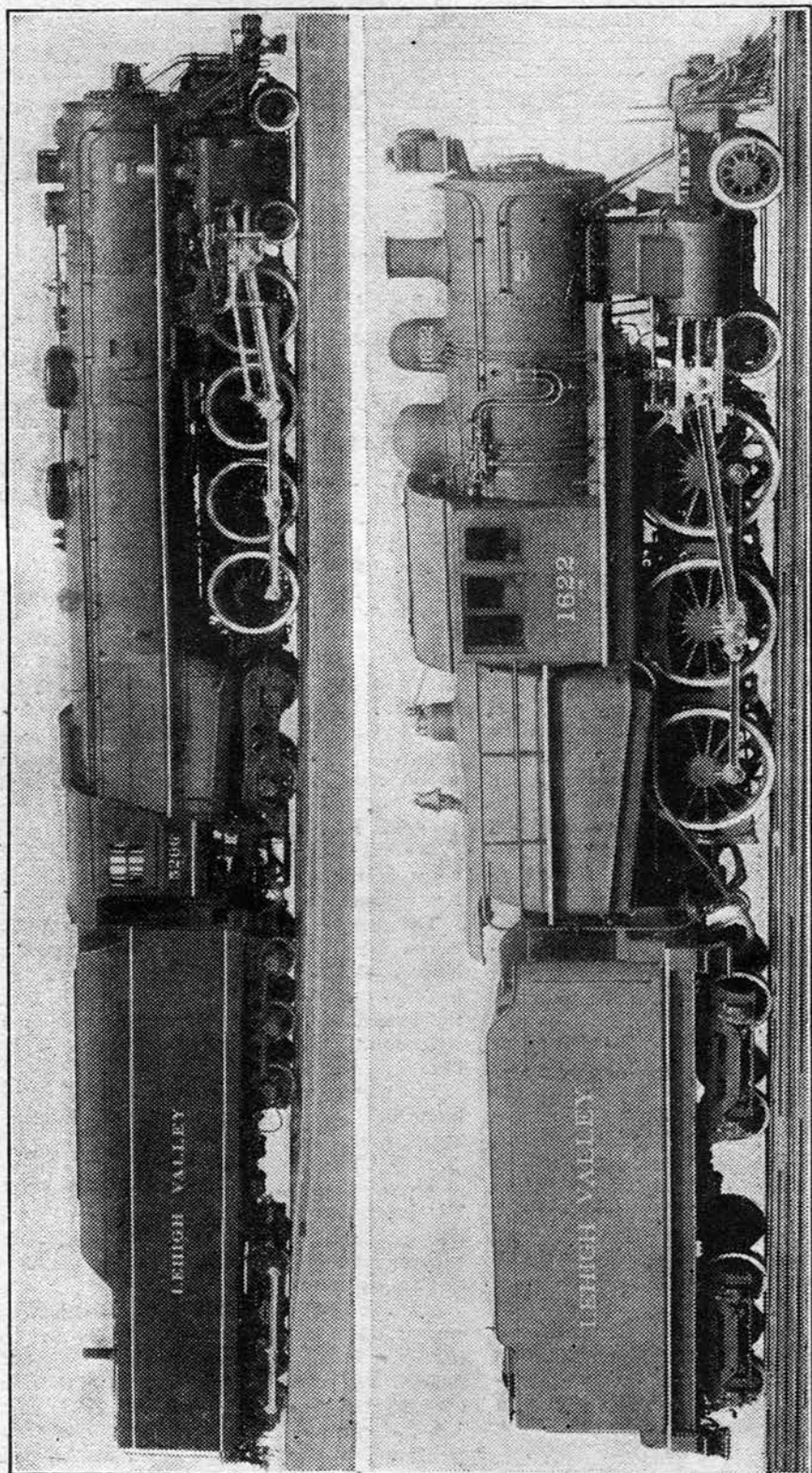

### Twenty-Five Years of Locomotive Development

No. 5206, Class T-2 (Upper), One of the Lehigh Valley's Highly Successful 4-8-4 Types, When Contrasted with No. 1622 (No Longer in Existence, but with Same Dimensions as Present Class J-55½), Tells the Story of American Motive Power from 1907 to 1932. But the 5206 and Her Sisters Are Primarily Freight Haulers. The Latest Development in 4-8-4's Is Class T-3, with Enough Power to Pull the Heaviest Freights and Enough Speed (Because of High Drivers) to Wheel the Fastest Passenger Expresses

Next Month: Seaboard Air Line Ry.

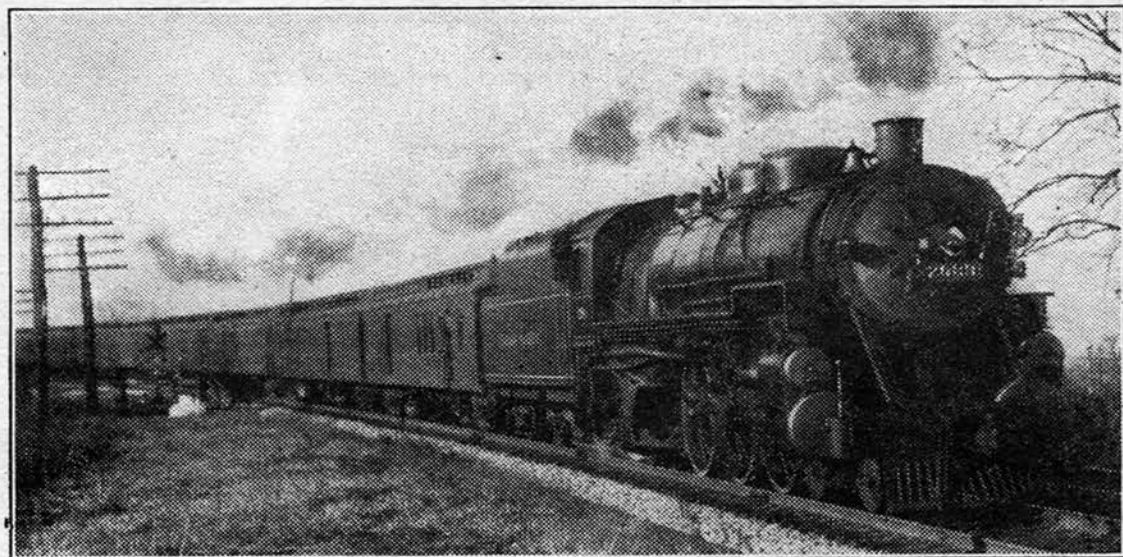
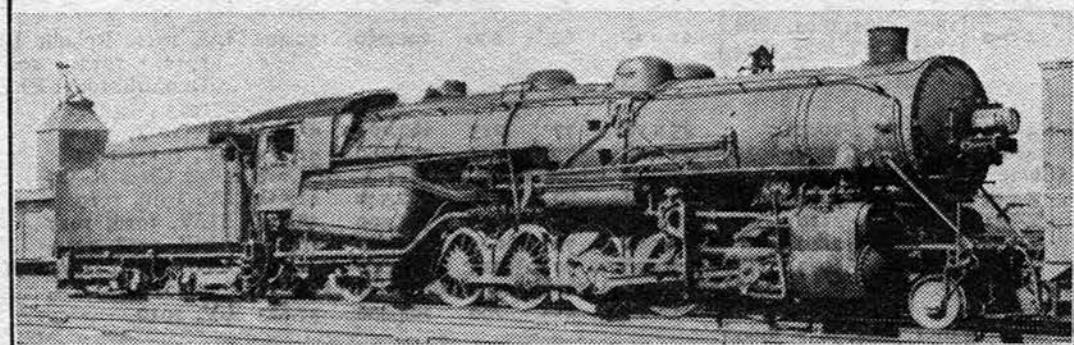
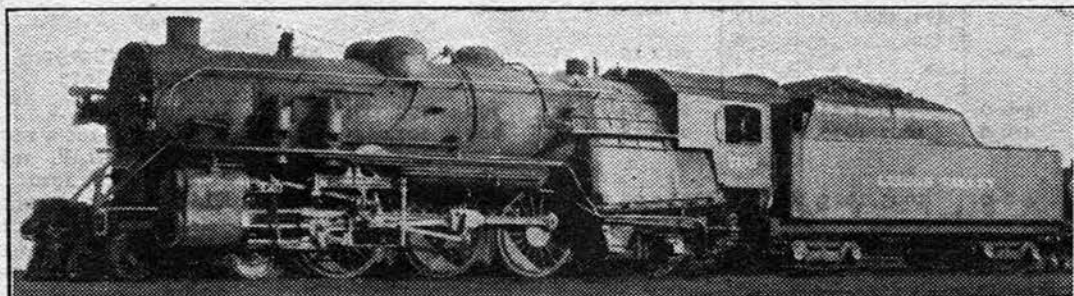

Photo by R. P. Morris, 47 Elm St., Elizabeth, N. J.

Lehigh Valley Train No. 2, "The Toronto," Hauled by No. 2089, Snapped at High Speed near Bound Brook, N. J.

Class	Type	Numbers	Cylinder Dimensions (Inches)	Driver Diameters (Inches)	Boiler Pressure (Pounds)	Weight without Tender (Pounds)	Tractive Force (Pounds)	Builder and Date
A-1	4-2-4	1 (sold)	11 x 20	56	140	77,955	5,189	LV, 1884
B-1	0-4-0	3500	16 x 24	48	180	97,000	19,584	Alco, 1906
G-1	0-6-0	dismantled	14 x 18	33	120	52,300	10,905	
G-7	0-6-0			44	130	88,490	17,000	
G-8	0-6-0			51	130	129,870	20,000	
G-10½	0-6-0	3354, 3358, 3359	20 x 24	51	150	119,610	24,000	BLW, 1891. Rebuilt LV, 1918
G-13	0-6-0	dismantled	20 x 24	51	170	125,180	27,200	
G-14	0-6-0	{ 3421, 3424, 3425, 3427, 3430, 3433, 3434, 3436, 3438, 3441, 3443, 3445, 3448, 3451 }	20 x 24	51	180	127,550	28,800	BLW, 1907, 1910; LV, 1911-1913
J-25	4-6-0	1131-1165	20 x 24	63	190	137,000	24,609	LV, 1917
J-55	4-6-0	1602, 1639, 1682	23 x 28	69	205	207,234	37,406	BLW, 1904, 1906, 1908; Rebuilt BLW, 1916, 1923; Alco, 1922
J-55½	4-6-0	1605, 1623, 1671	21 x 28	69	205	207,234	31,183	BLW, 1904, 1905, 1907. Rebuilt LV, 1929, 1923; Dunkirk, 1922
J-56	4-6-0	1809, 1811, 1812, 1819	23 x 28	69	200	202,050	36,493	LV, 1911, 1912, 1916, 1918
J-56½	4-6-0	1820	23 x 28	73	200	200,200	34,493	LV, 1912
J-57	4-6-0	{ 1800, 1801, 1802, 1804, 1805, 1808, 1813, 1814 }	21 x 28	69	200	202,050	30,422	LV, 1911. Rebuilt LV, 1912, 1913, 1923; Dunkirk, 1923; BLW, 1923
K-2½	4-6-2	2010-2020	25 x 28	77	215	262,160	41,534	LV, 1913, 1914
K-3	4-6-2	2021-2024; 2026-2035	25 x 28	77	215	271,380	41,534	LV, 1917, 1921
		(Some weigh 278,000 lbs., have boosters which exert 10,400 lbs. t.f.; are called Class K-3b)						
K-4	4-6-2	2050-2064	25 x 28	77	215	262,540	41,534	LV, 1916, 1917
K-5	4-6-2	2100-2120	27 x 28	73	205	301,500	48,723	BLW, 1916, 1917
K-5½	4-6-2	2130-2149	27 x 28	73	205	311,900	48,723	BLW, 1918, 1919
K-6	4-6-2	2088-2099	25 x 28	77	215	291,000	41,534	Alco, 1924; LV, 1925, 1926
		(This class has booster which exerts 10,400 lbs. t.f.)						
L-2	0-8-0	3048, 3049	21 x 28	55½	200	164,000	37,823	LV, 1910
L-3	0-8-0	{ 3051, 3054, 3055, 3060, 3061, 3063, 3065, 3066, 3068, 3069 }	21 x 28	55½	200	174,850	37,823	BLW, 1905, 1907; Alco, 1908; LV, 1910

L-4	0-8-0	3100, 3102	21 X 28	51	200	158,775	41,160	LV, 1912
L-5	0-8-0	{ 3125-3128, 3132, 3133, 3137, 3138, 3139, 3143, 3145, 3148, 3150-3157, 3159, 3142, 3160, 3162- 3172, 3174 3176-3210 }	21 X 28	51	200	173,500	41,160	LV, 1911, 1912, 1913, 1915; BLW, 1916
L-5½	0-8-0	3172, 3174 3176-3210	22 X 30	55½	205	208,935	45,587	LV, 1910, 1912, 1913. Rebuilt 1924 to 1929
L-6	0-8-0	dismantled	{ 23 X 30 20 X 24 }	55½	200	224,370	48,610	
M-17	2-8-0			50	145	125,925	23,903	
M-35	2-8-0	{ 706, 724, 729, 749, 760, 764, 784, 786, 796, 798, 805, 808 }	21 X 30	62½	205	211,420	36,885	BLW, 1899, 1900, 1901, 1902; Rebuilt BLW, 1915
M-36	2-8-0	815	23 X 30	62½	205	214,900	44,245	Alco, 1907; Rebuilt BLW, 1916
M-36½	2-8-0	dismantled	{ 21½ X 30 23 X 30 }	62½	205	211,420	40,482	
M-37	2-8-0			55½	200	226,800	48,610	
N-1	2-8-2	300-341	22½ X 28	56	200	234,810	43,031	
N-2	2-8-2			27 X 30	56	175	322,000	
N-2½	2-8-2	350-394	27 X 30	63	190	318,400	56,063	BLW, 1912, 1913 BLW, 1913, 1916
N-3	2-8-2	395-424	27 X 30	63	190	325,000	56,063	BLW, 1916, 1921, 1922
N-4	2-8-2	425-484, 460-464	27 X 30	63	200	326,340	59,000	BLW, 1923
N-5	2-8-2	440-459, 465-499	27 X 32	63	200	325,000	63,000	Alco, 1923, 1924 (This class has booster which exerts 10,000 lbs. t.f.)
N-6	2-8-2	275-204	27 X 32	63	200	328,360	63,000	BLW, 1917; Rebuilt LV, 1928, 1929 (This class has booster which exerts 14,400 lbs. t.f.)
R-1	2-10-2	{ 4000, 4001, 4003, 4004, 4011, 4012, 4017, 4020, 4021, 4022, 4024, 4026, 4028, 4030, 4031, 4033- 4037, 4040-4059 }	29 X 32	63	200	374,100	72,260	BLW, 1917, 1919 (Some have tender boosters exerting 14,400 lbs. t.f. and 12,335 lbs. t.f.; are called Class R-1b)
S-1	4-8-2	5000-5005	25 X 28	69	200	360,000	64,700	Alco, 1923, 1924
T-1	4-8-4	5100-5110	27 X 30	70	250	408,000	66,400	BLW, 1931, 1932
T-2	4-8-4	5200-5210	26 X 32	70	225	422,000	66,700	Alco, 1931, 1932 (Classes T-1, T-2 have tender boosters exerting 18,360 lbs. t.f.)
T-3	4-8-4	5125-5129	27 X 30	77	275	439,000	66,500	BLW, 1934



Lewistown No. 4059 (Lower) Was Photographed by F. J. Quin, 190 Rocklyn Ave., Lynbrook, N. Y.  
Whoever Took No. 3132 (Upper) Forgot to Put His Name on Back of the Photo.



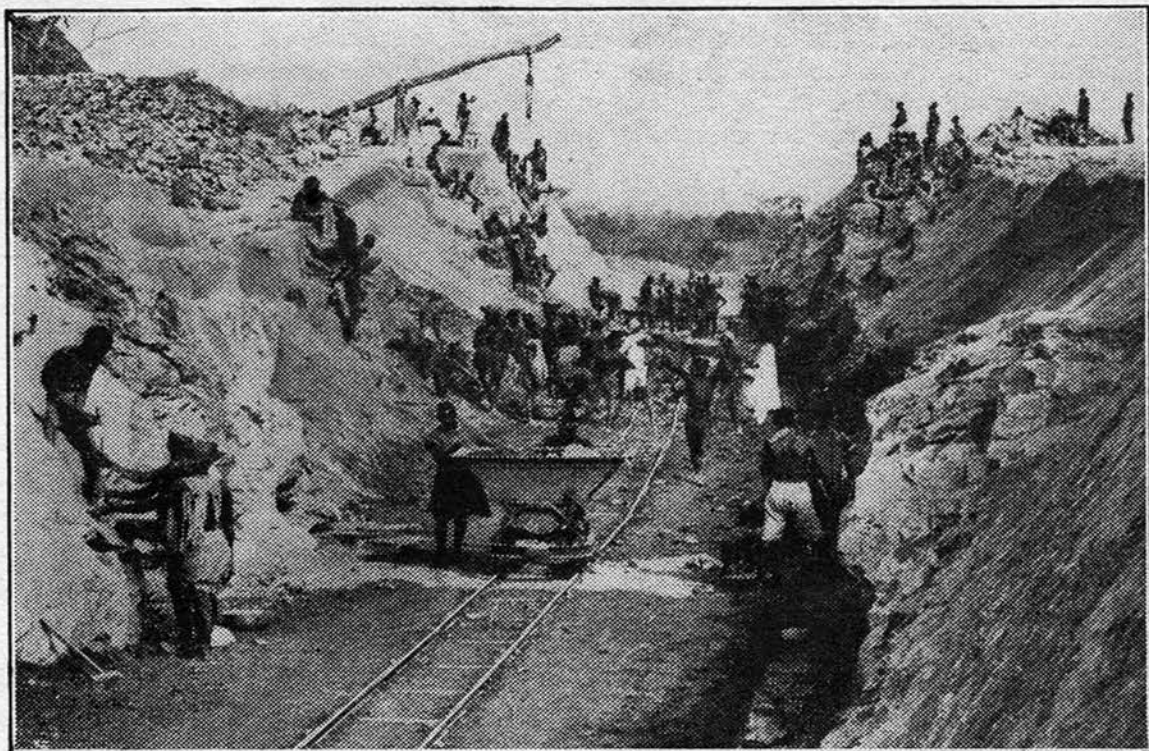

Natives Such as These Were Very Much to the Taste of the Lions Which Infested Uganda, and When They Constructed the Uganda Railway Their Biggest Job Was to Defend Themselves against the Savage Man-Eaters

# Into the Dark Continent

By CHARLES FREDERICK CARTER

Former Trainman; Author of "Hill Against Harriman," etc.

**T**HEY were building an iron trail through the jungles of British East Africa. Roger Kent-Coverdale, chief engineer of the Uganda Railway, was talking to J. H. Patterson, engineer of construction, who had just arrived from England, on a March day in 1898.

The scene was in the brand new club in the brand new port of Kilindini, built to order for the terminus of the Uganda Railway on the Indian Ocean. The two men had settled back to enjoy such comfort as the stifling heat permitted. With a ghost of a smile Kent-Coverdale remarked:

"I would like to offer a word of caution,

old chap. In this savage country less than a hundred miles south of the equator—with its wild men, wild beasts, deadly insects, disease, famine and thirst—you never dare overlook things that may seem trifles to a newcomer. For example, did you hear what knocked out your predecessor?"

"No," said Patterson.

"A chigger," explained his superior. "A bally little tick—a trifling insect that seems to strangers not worth noticing. Chiggers burrow under men's toenails and cause abscesses. The infected toe was neglected one day too long in this fearful damp heat, and the foot had to be amputated!"

Patterson straightened up.

"Tick bites are not trifles," the other man went on. "That's just a sample of what you'll be up against constantly. Insects cause a lot of trouble. Work beyond railhead has been held up for a month by the flies."

Patterson raised an eyebrow. "Are you pulling my leg?" he asked in British slang.

"No, indeed," Kent-Coverdale assured him. "Tsetse flies have killed off all transport animals we have been able to send forward—horses, mules, donkeys, bullocks, camels. They are deadly to human beings also, because they transmit germs of sleeping sickness, which has carried off upward of two hundred thousand natives in the last five years. Now we are entirely without means of transportation beyond the end of track. The first and most important

problem you must solve—or help to solve—is how to raise the fly blockade."

"Of course the railroad will be built somehow in spite of all obstacles," Patterson insisted. "England's honor is at stake."

"Yes, I know," said the chief. "This line is the only railroad I know of that is being laid for sentimental reasons. You've heard the story. By agreement of the Great Powers at the Brussels conference, July 2, 1890, England undertook to build a railroad through East Africa from the Indian Ocean to Victoria Nyanza. This lake is really an inland sea with an area of 27,000 square miles—more than half the size of England! You know why we're doing this job?"

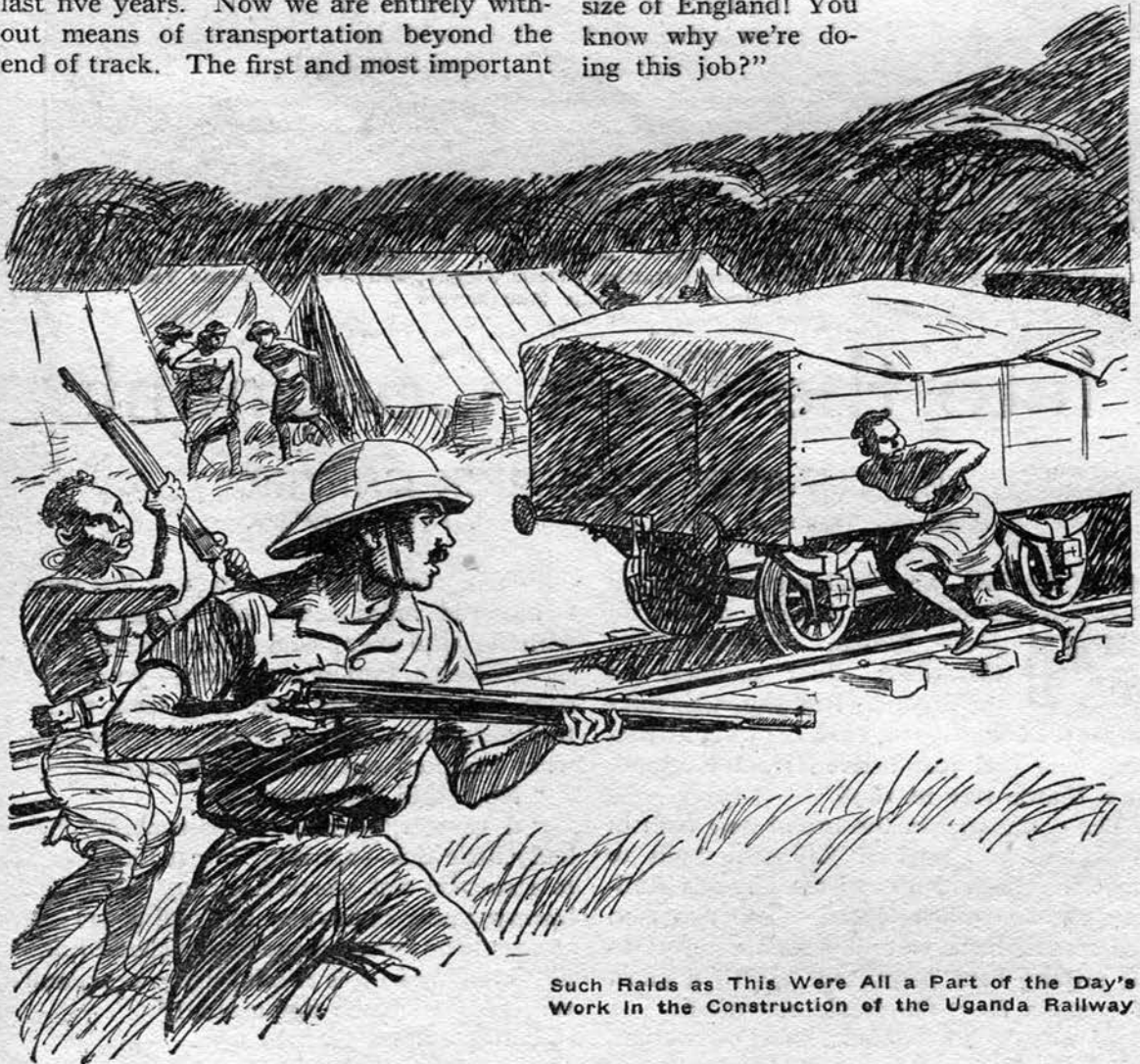

Such Raids as This Were All a Part of the Day's Work in the Construction of the Uganda Railway

"Yes," said the newcomer. "We could keep Arab slave raiders out of this country by using the combined facilities of rail and lake transportation. This would just about be a death blow to slavery, which has become a stench in the nostrils of civilization. But about the matter of transportation, couldn't we get enough native porters to carry the absolutely necessary supplies beyond the end of track?"

The chief shook his head.

"The natives here won't work. They have never felt the need of labor. Nature provides. So everything has to be done by Hindu coolies imported under contract.

Coolies are useless as porters. Not strong enough."

Patterson had a bright idea.

"I've heard a lot about Swahilis," he said, "those sturdy fellows from up-country on whom explorers and big game hunters depend. Let's try them."

Kent-Coverdale assented.

"And why not cable back home for some steam lorries?" suggested Patterson.

The chief agreed to this also.

**I**N due time Patterson ventured out in the blazing sun. Protected by Cawnpore helmet and spine pad, he made a tour

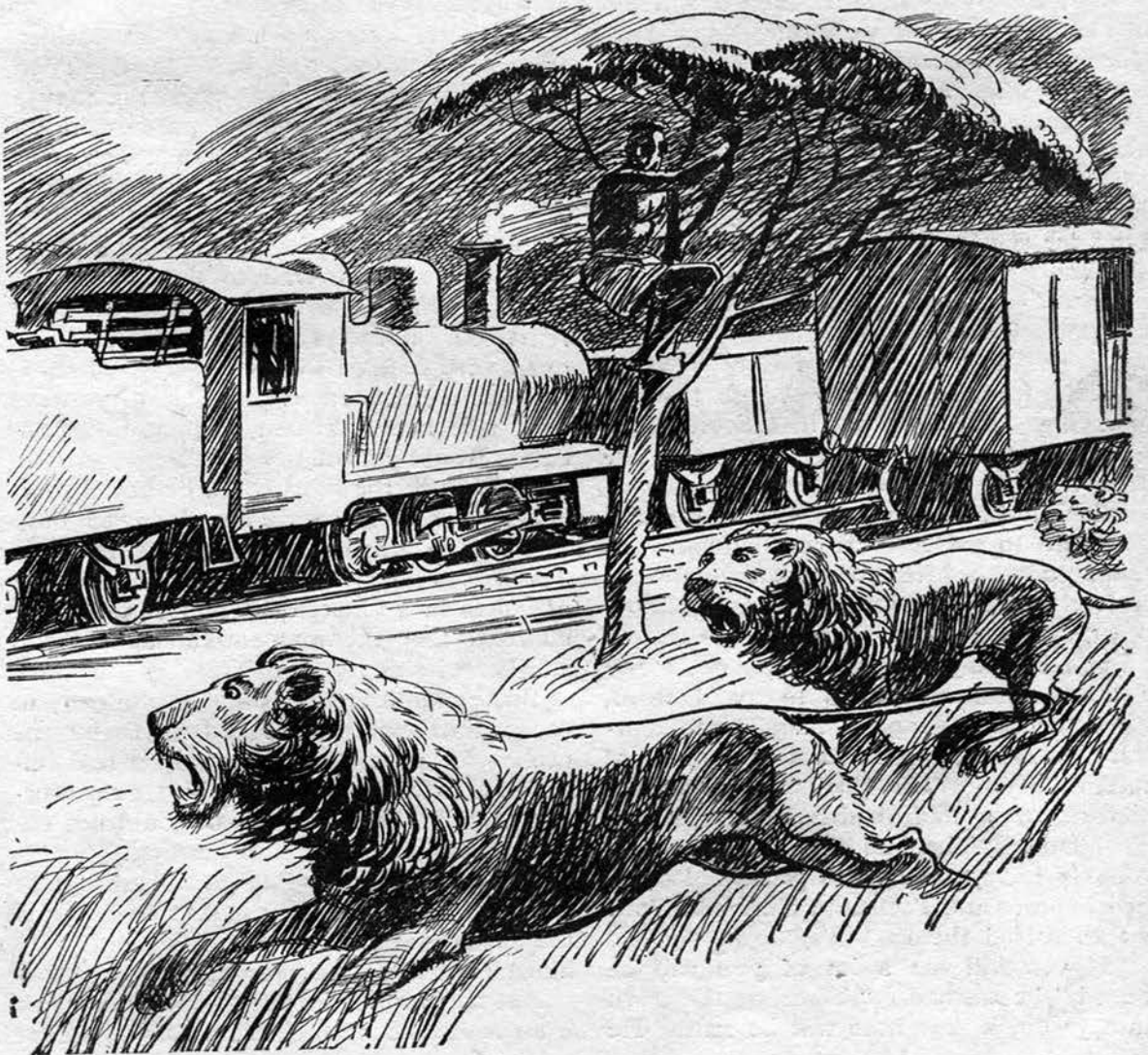

to inspect arrangements for receiving supplies and forwarding them to the front.

Through the new port of Kilindini they had to import not only all railway materials, but every pound of food for Europeans and Hindus. Food for the former came from England and food for the Hindus came from India.

Patterson went up the line to the end of track at Tsavo River, 131 miles from Kilindini. This river was to be crossed by the largest bridge on the line. Beyond it all operations were still blocked by tsetse flies, among which no domestic animals could live.

To raise the fly blockade, pending arrival of the Swahili porters, Patterson put all available men at work building a temporary bridge strong enough to carry a locomotive and a few cars across to the other side to move up supplies so that grading could be resumed.

That done, the new engineer of construction scouted around the vicinity for material for the stone bridge piers.

It had been planned to bring stone from the coast — a long haul that would tax transportation facilities needed for other uses. But Patterson found right at hand the stone he needed, and put men to work quarrying and dressing it. Soon three thousand coolies were busy along the line for a distance of eight miles.

When it became known that stone masons were to get forty rupees a month, as compared with fifteen rupees the laborers received, the whole force suddenly discovered they were skilled stone masons.

Upon learning this would not do, many of them shammed illness to avoid work, and schemed revenge. They lured Patterson to a lonely spot for the purpose of murdering him. The Englishman was surrounded by a mob which began jostling him about. If he had fallen, they would probably have torn him to pieces. Realizing what was up, Patterson climbed a rock and addressed them.

"If you kill me a lot of you will be hanged," he warned. "Then, as the work must go on, a new boss will be sent. He

may be much harder on you than I have been. Get back to your jobs!"

Patterson was a man of few words. He was lean and sinewy, with a stern expression that counted for much with these people. His six feet two inches of stature, towering far over the puny coolies, also had its effect.

What happened that evening did more than anything else to alter the coolie attitude toward their English boss. About midnight the camp was in an uproar. Investigating, Patterson found that a lion had walked into a tent in which a dozen coolies were asleep and had carried off Ungan Singh, their foreman.

Ungan Singh called out: "*Choro!*" (Let go.) But Mr. Lion seized the luckless man by the neck and killed him. Then, picking him up as a cat carries a mouse, the lion stalked off to its partner in the jungle and ate poor Ungan Singh with sickening noises plainly heard in camp.

**N**EXT morning Patterson, with a party, followed the trail to the spot where the body had been eaten. Only the head remained. Dead eyes were staring wide open with a fixed look of horror.

That night, gun in hand, Patterson sat in a tree near the tent, hoping the man-eaters would return.

After dark the lions could be heard roaring in the distance. Then followed deep silence, for lions do not roar when hunting. Two hours later wild screams and a babble of voices in a different section of camp announced that the man-eaters had claimed another victim.

Being almost the only European in camp, Patterson was looked up to by the coolies for protection. But as he had important duties which kept him busy during daylight, the Englishman could not devote all his nights to lion hunting.

The next evening Patterson had a goat tied for bait in front of the tent from which the latest victim had been dragged. He himself sat in a tree over it.

But all in vain! About midnight screams from a distant part of camp told him that



The Congo Isn't Within Hollering Distance of Uganda, but Operating Conditions Are Much the Same. The Fireman of This "Mixed" Train Running through the Congo Is Getting a Little Help from His Less Ritzy Passengers in Fueling up His Hump-backed Hog

the man-eaters had made another human kill. In a camp scattered for eight miles through the jungle it was only by chance that Patterson could guess where the next attack would come.

The man-eaters were entirely without fear. Boldly they walked past huge fires kept burning to frighten them away. Guns fired in their direction, after they had made their kill, did not disturb their horrid feast.

Then all the workers were concentrated in one huge camp protected by a *boma* of thorn bushes so thick and high that the railroad builders hoped it would turn even a determined lion. But it didn't. No wonder the Hindus came to believe the man-eaters were devils.

One night Patterson and Dr. Brock, the medical officer, posted themselves in a box car on the siding. The lower half of the door was closed.

This did not suit Patterson. He wanted to lie *under* the car, where he thought he

would have a better chance for a shot. Fortunately Dr. Brock persuaded him to stay *inside* the car.

Soon they heard an animal approaching stealthily. After a few seconds of dead silence the king of beasts, with a blood-curdling roar, leaped at the half-open door.

Both men fired together. Neither scored a hit, but the flash of their guns caused the lion to swerve and strike the side of the car instead of landing within. Mr. Lion retreated into the jungle and did not return.

A few days later District Officer Whitehead, a noted lion hunter, arranged to come up and try his luck. His train was late. Whitehead, accompanied by Abdullah, a sergeant of railroad police, set out in the darkness for Patterson's camp.

As they were passing through a cut, a lion sprang on Whitehead's back, tearing off his clothes with one swipe of a huge paw. But Whitehead managed to fire his carbine. The flash caused the lion to turn

attention to Abdullah. With another spring he knocked down the sergeant, killed him and carried him off. Whitehead, terribly frightened, passed the night in a tree.

At length came the Swahili porters who had been sent for, and with their help operations were extended somewhat. Porters were not enough. Something more was needed.

After long delay and much cabling, Patterson received the steam lorries he had ordered the day he landed. But no water could be spared for their boilers, so they were soon abandoned. This, of course, was before the day of modern motor trucks.

The railroad was now entering on a long stretch of desert. Keeping the men supplied with drinking water was a difficult problem. After the track was laid, locomotives were provided with extra large tenders for additional water, and a water car was coupled in behind the tenders. So bad was the water that locomotive boilers had to be washed out every night.

As the railroad was a British Government job, nothing could be allowed to hinder or delay it. Patterson cabled for more coolies until he had ten thousand of them scattered along the works.

His detour of Tsavo River bridge furnished the key to a solution of transport difficulties. Whenever an unusually difficult stretch was encountered, as many men as could be used effectively were put on it. At the same time a "shoo-fly" (temporary track) was laid around it.

In crossing the great Rift Valley supplies were lowered down a cableway 1,500 feet long while the road was being built down a very steep mountain side. Swahili porters did the rest. By such expedients the work was kept going on a wide front. As the isolated bits of grade were completed and connected up, the main line was moved forward, over temporary bridges when necessary. The shoo-flies were taken up and moved ahead.

Patterson was here, there, and everywhere, always with a gun bearer at his

elbow, for man-eating lions were always at the back of his mind. For nearly nine months he carried on an almost nightly campaign against the beasts without once catching sight of them.

This strain of hard work in a trying climate, with sleepless nights, was beginning to tell on him. The engineer became so thin and haggard that he facetiously remarked:

"I'm safe from the lions, because I'm too lean and scrawny to be good eating."

One night a lion sprang into the car of Ryall, superintendent of police, which stood on a siding; carried him off and ate him.

Patterson decided on a new plan. A hut was built in two compartments of ties and steel rails bolted together. One end was like a rat trap, with a door of steel rails arranged to drop when a lion stepped on a treadle within. As a lure, four Sepoy soldiers were placed in the other compartment behind a grille of steel rails.

Being utterly fearless, a lion walked into the trap the first night. The steel door fell with a fearful clatter. Mr. Lion roared and charged around, trying to get out.

Instead of shooting the beast as they had been told, the Sepoys became panic-stricken and fired wildly. Their bullets whined close to Patterson and Superintendent Farquharson at right angles to the trap. They kept on firing recklessly until they shot away a bar of the gate. Whereupon the animal escaped.

By this time the coolies were frightened so badly that they resigned in a body, taking possession of trains bound for the coast and departing—all but a few skilled men who cowered in the *boma*, refusing to work and sleeping in treetops.

The lions had held up the Uganda Railway! All work was stopped for three weeks.

ONE night the lions killed a donkey in camp and ate part of it. Thinking they would return to their kill, as is their habit, Patterson had four poles set in the earth ten feet from the donkey. The tops

were lashed together and a board was tied on for a seat.

On this crazy *machan* Patterson, gun in hand, posted himself at dusk. He did not have to wait long until he heard the stealthy approach of a lion.

Soon he realized, to his horror, that *the lion was stalking him!* Around and around it circled, making up its mind to spring, but keeping out of sight.

At last he caught a glimpse of the beast, and fired. With a roar the monster sprang away, followed by a second bullet which brought another roar. After that, silence.

The shots aroused the camp. Patterson called out that he had shot the lion. This brought a group of men cautiously carrying lights and making as much noise as possible. They found the lion stone dead, less than a hundred yards from the *machan*, crouched as if for a spring. It measured nine feet, ten inches in length. Eight men carried it to camp.

"*Mabaraki!* (savior)," chanted the coolies as they bore Patterson in triumph around the animal's body. Half their troubles were ended. One pair of lions evidently had caused most of their losses.

A few nights later the surviving man-eater tried to get a right-of-way inspector who was sitting on the veranda of his iron shanty. It failed, but ate a couple of goats on the spot.

Next night Patterson posted himself in an iron shanty near by, with a loophole covering three live goats for bait tied to a section of steel rail. Just before dawn a lion dragged away all three goats and the rail. Patterson fired, but only killed one of the goats.

In the morning the lion was found still eating a goat. A *machan* was built near by, on which the engineer took his post in the evening, with his native gun bearer, who watched while the worn-out Englishman slept. Patterson was aroused by a touch on his arm.

"Lion!" whispered the gun bearer.

Patterson could see the outline of a lion under the *machan*. He fired both barrels of his gun. The beast went down. In an

instant it was up and bounding off, roaring at each leap.

Following a blood-stained trail next morning, Patterson and a party were soon stopped by a growl. The monster was glaring at them a few yards ahead.

Patterson fired and hit. The lion charged. A second shot knocked it down, but instantly the beast was up and charging. When Patterson put out his hand for his carbine it wasn't there. His gun bearer had climbed a tree.

Fortunately a shot had broken one of the animal's hind legs, and Patterson barely had time to swing himself up out of reach. The lion, growling, turned back. Then Patterson, getting his carbine, fired. His shot killed the savage man-eater.

The Hindus who, months before, had sought to murder Patterson, now could not do enough for him. They gave him an elaborate silver bowl and a long poem in Hindustani telling the story of his campaign against the man-eaters.

**B**UT this was only one of the vexatious problems in building the Uganda Railway. After the man-eaters came fever.

In one gang of 320 men, 280 were down with fever at one time. On another occasion a roundhouse foreman and ten out of eleven engine drivers were stricken together. Patterson himself took out a locomotive one trip in order to prevent stoppage of work on an important job.

Difficulties of engineering and construction were great. The country is very mountainous. It was up one range and down another all the way on an extremely crooked alignment made necessary to hold the grade down to two per cent, which was all the little locomotive could climb with a paying load. One range was crossed at an altitude of 7,700 feet, another at 8,300!

At last the job was finished! The first locomotive entered Port Florence on Victoria Nyanza, 582 miles from Kilindini, the day after Christmas, 1901. Then Engineer Patterson started back to England, where he could forget all about man-eating lions and tsetse flies and fever.

# Who's Who in the Crew



BORN MARCH 25, 1893, IN LOG CABIN IN KENTUCKY. FATHER WAS A SECTION HAND. TWO SISTERS MARRIED TRAINMEN.

BOZO'S FIRST JOB WAS SNIPE ON AN ELECTRIC LINE AT NEW CASTLE, IND., IN 1911. WENT TO TEXAS IN 1912 AND HAS LIVED THERE EVER SINCE. WORKED ON THE SAN ANTONIO, UVALDE & GULF (MO. P.) IN BRIDGE GANG, AS CALL BOY, MACHINIST HELPER, BRAKEMAN AND IN MANY OTHER JOBS, INCLUDING NIGHT ROUNDHOUSE FOREMAN AT CRYSTAL CITY. WHILE WORKING AT PLEASANTON HE MET GERTRUDE PRESTON, MASTER MECHANIC'S STENOGRAPHER, WHOM HE MARRIED APRIL 10, 1920

## "BOZO TEXINO"

J. H. MCKINLEY  
2210 COKE STREET,  
LAREDO, TEXAS

AS BOSS HOSTLER HE RAN LOCOMOTIVES BEFORE HE EVER FIRED ONE. WAS

STARTED IN ENGINE SERVICE BY A BOOMER MACHINIST, H. M. WARDEN, NOW M-K-T CHIEF MECHANICAL OFFICER. BECAME S. A. U. & G. FIREMAN IN 1914. LATER FIRED ON THE TEXAS & PACIFIC AND THE INTERNATIONAL & GREAT NORTHERN (MO. P.). PROMOTED TO ENGINEER IN 1928. NOW WORKING ON SAN ANTONIO DIVISION

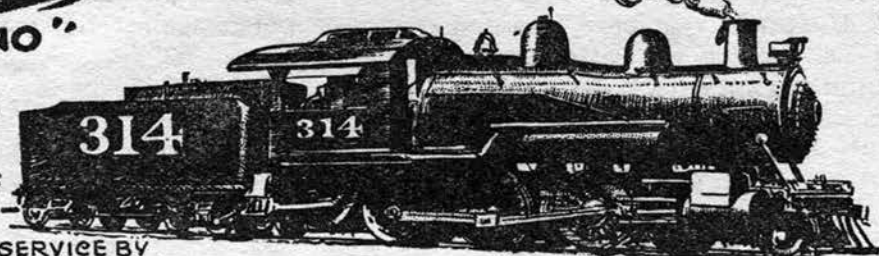

ONE OF THE ENGINES FIRED BY HIM



His TRADEMARK.

HIS BIGGEST THRILL WAS RIDING A BRAKE BEAM UNDER

A LOCOMOTIVE. HAS BEEN WRITING FOR "MO. P. MAGAZINE" SINCE 1925 AND FOR "RAILROAD STORIES" SINCE 1931. WON MO. P. \$25 PRIZE FOR ARTICLE ON "ELIMINATE ROUGH HANDLING OF EQUIPMENT AND CONTENTS." MEMBER B. of L. F. & E. LODGE No. 263.



MRS. BOZO TEXINO

Next Month ("Famous Engineers")—J. H. WILLIAMS, Rock Island



# Rights Over Everything

*The Mysterious Adventures of K. C. Jones;  
or, Fiction Is Stranger Than Truth!*

By BOZO TEXINO

ANSAS CITY" JONES slowly arose from the ground, shook his clothing free of cinders, and clenched his fist at the tail lights of the "Mountain Bullet," now vanishing around a curve.

A passer-by would have guessed that K. C. Jones had been ejected from the Rocky Route freight train by an unfriendly brakeman. Such, indeed, was the case. For K. C. was on the bum. A typical Charlie Tyler fiction hero! His overalls were ragged, his cheeks unshaven and his blue eyes peered out from a face made lean and cavernous by hunger.

Two years before, K. C. Jones had been the best damned hoghead on the Mountain Division of the Rocky Route Railroad—even better than old Dave Morrow in Layng's story, "Riders of the Iron Trail." One night the boomer op at Big Top, who had been drinking too freely, fell asleep on the job, but woke just in time to throw a red board in K. C.'s face. A hundred yards ahead of his pilot the lights of a crummy twinkled in the murk.

For one terrible moment fear clutched at K. C.'s heart. Then he made a characteristic John Johns stop, flattening all the wheels. With a sweep of his brawny arm K. C. wiped the clock and then joined the birds—which means applied the emergency brake and jumped. The next instant his 1217

plowed into the caboose like a buzz saw eating through Alabama pine. Unfortunately for K. C.'s peace of mind, his fireman stayed in the cab and died "a-scalded to death by the steam," as the poet says.

Brass hats placed the blame squarely upon the shoulders of the flagman of one train, who was killed, and the hogger of the other, K. C. Jones, who failed to show up for the investigation. They did not know—and never would know—that the lightning slinger at Big Top had failed to hang out the red until it was too late. K. C. would not tell them, for the op was K. C.'s own father, working under a flag, just as they do in Frank L. Packard yarns. And nobody else could tell, because nobody else was in on the secret.

Thus it happened that the mighty K. C. Jones, branded as yellow, took the long and weary boomer trail that led from Winnipeg to the Gulf, and from Portland, Maine, to Portland, Oregon.

It had been hard to leave the Rocky Route. Hard also to quit the throttle of the "Mountain Bullet," to which he had been promoted just before the wreck at Big Top. Harder still to go away from Highland Mary, the general manager's daughter, without even clearing himself of a stigma which filled her limpid eyes with tears of shame and disappointment.

"Some day I'll come back," he mut-

tered grimly, his eyes narrowing to slits, like the villain in a "Boomer Bill" Hayes story.

Little did he know how near he was to fulfillment of his dream that night he was thrown out of a side-door Pullman on the "Mountain Bullet." For, like a weary wanderer lured by the lights in the window, K. C. Jones had drifted back to Big Top and the road he loved so well.

The ex-hogger arrived at the right time. Near the signal tower stood a gold train headed by the 998½, ready to highball gold bullion to the New Orleans mint, which was badly needed to meet the demands of inflationists.

The general manager and his daughter were riding this train. Highland Mary had been spending a vacation in California at Glendale, home town of the famous Charles W. Tyler, and was returning to her job as telegraph operator in New Orleans. K. C. was trying to figure out where he'd go next when he suddenly saw Highland and her dad board the private car. He didn't know where they were going, but decided he'd go there, too.

Climbing into the cab, K. C. showed his Brotherhood card and International Engine Picture Club button to the hogger and asked:

"How's chances of riding this here gold special to New Orleans?"

"Nothin' doin'," the hogger replied sourly. "This train is loaded down with guards an' gumshoes, an' the G. M. is on board. We have nothin' but an express car, passenger coach an' the G. M.'s private car, so there's no place for a boomer to ride."

K. C. threatened for a while, and then he calmed down, thinking of the beautiful Highland Mary.

Before K. C.'s smash-up at Big Top, the general manager had transferred

his daughter from the Mountain Division to New Orleans. He didn't like the way K. C. steered Highland around the dance hall floor at the employees' dances. He thought K. C. was rough-handling her. He wanted her to dance with the downtown cake-eaters, but he found out K. C. had Highland backed into the siding with both switches spiked down.

**K.** C. JONES slid out of the cab of the 998½ and walked back on the fireman's side of the special. He unlatched the door on the "possum belly" under the private car, where he intended to ride if he couldn't ride anywhere else. He'd read of the tricks tried by that fellow in "Beginner's Luck," by Dave Martin, and K. C. decided to follow suit.

K. C. had procured a pair of dark sun glasses from the five and dime store for twenty cents, which he put on as a disguise. Knowing that Highland Mary was on this train, nothing could hold him back. If there was anything he loved more than engines and engine pictures, it was this snappy little redhead with eyes like Scotch heather and an old man tighter than any Scot ever hoped to be.

Glancing around cautiously K. C. saw the conductor coming with orders. The con was a slick fellow. They nicknamed him "Slippery Buck," after one of Jimmy Earp's fiction characters. K. C. crawled into the possum belly, pulled the door shut, peeped out and, when the con stopped there to trim his lantern wick, read the following train order:

**Engine 998½ extra Big Top to New Orleans with rights over all trains.**

Rights over everything! K. C. sighed and groaned. What wouldn't he give

to sit at the throttle of the 998½ with an order like that in his overalls pocket.

A moment later Slippery was bawling out, "All abo-o-o-ard!" And the special was on her way. No. 998½ was pulling an express car loaded with the gold and a flock of gumshoes carrying sawed-off shotguns. Also a coach containing some more gumshoes and the train crew.

The rear car was the general manager's private buggy, under which the mighty K. C. Jones was riding as uninvited guest. K. C. had spread out some waste for a mattress, with a nice soft coupler knuckle as pillow. Thus his berth was made down for the record run.

For it would be a record run, he knew. While on the bum he had heard from other members of the unwashed fraternity that the huge shipment for the New Orleans mint had been split two ways. Half of it was going by the iron trail and the other half by the Tailspin Airways. A plane loaded with the precious bullion was to make a test trip, and whichever form of transportation was first to reach New Orleans with the gold would be awarded a big government contract.

The aviation outfit claimed they could easily beat the streak of rust. That is, if fair weather prevailed and if they didn't have to make a forced landing on a mountain top or down in the desert where gila monsters fight the rattlers and, according to Western fiction writers, the country is infested with bandits, train robbers, rustlers and crooked sheriffs.

These thoughts were driving the cobwebs out of K. C.'s brain as the gold special was humming along the twin ribbons of steel. The boomer engineer kicked off the inside top board

of the possum belly so he'd have more air while crossing the sun-scorched desert, and for observation purposes. He'd have to lay low, though, whenever the train stopped, so no one could see him. He hoped no snoopers were laying for him, for he had read about that trainmaster in Hilker's "Christmas Test," and knew how T. M.'s acted.

Up above him, on the brass hat's private chariot, Highland Mary had just gone out on the back porch for a breath of air, when—

**Z-Z-ZIP!** The brakes went into emergency. It developed that the engineer had seen a pile of black creosoted ties on the track, just like the hogheads do in railroad fiction. But alas, this wasn't fiction! It was the actual thing. A band of train robbers led by the notorious James Jesse II, lay hidden in a ravine. They turned a machine gun loose on the steel cab.

The special ground to a stop. Her engine crew had to lie down to get out of the range of bullets tattooing a design on the side of the 998½. Then the *rat-tat-tat* ceased.

"Wonder what the dirty villains are up to now?" K. C. murmured breathlessly, still keeping out of sight.

He soon learned. J. J. II himself and his chief lieutenant, Alkali Ike, rushed forward, covered the engine crew with pocket-size cannons, and hog-tied them. K. C. darted out of his place of concealment, grabbed an armful of fuses and climbed onto the pilot of the 998½. From this vantage point he lighted one fusee after another and hurled them at the highwaymen.

By this time the guards and gumshoes had come to life. Sallying forth, they captured the bold, bad bandits, bound them securely and threw them

From This Vantage Point He Lighted  
One Fusee After Another and Hurlled  
Them at the Highwaymen

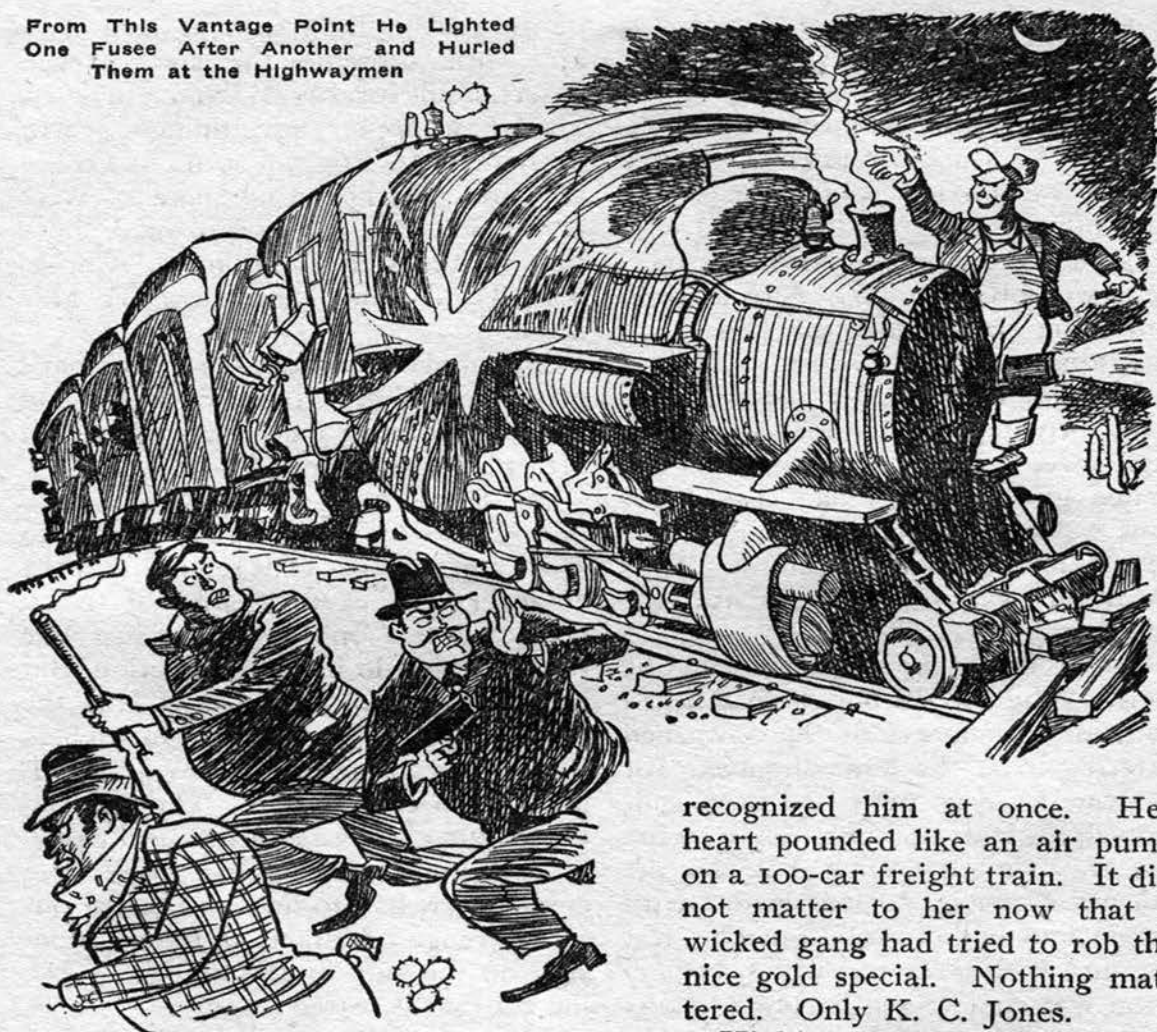

recognized him at once. Her heart pounded like an air pump on a 100-car freight train. It did not matter to her now that a wicked gang had tried to rob the nice gold special. Nothing mattered. Only K. C. Jones.

into the gold car to take back to New Orleans and collect the reward money. The gold was saved—for a while, anyhow.

K. C. untied the poor hoghead and tallowpot, and to them he thundered: "Back up a little, get a good start, and plow them ties off the track!"

With that the redoubtable K. C. Jones crawled back to his berth under the G. M.'s car; and the train was under way again, bearing eastward its cargo of precious yellow metal.

Highland Mary, standing on the observation end, her auburn hair fluttering in the breeze, saw her hero and

Highland was so excited, she scarcely slept a wink that night. She simply *had* to devise some means of communicating with the man riding directly underneath her bedroom. Then came a flash of inspiration. The girl remembered that she and K. C. had learned the Morse Code while playing as kids together, 'way back in Griff Crawford's home town of Wellington, Kansas. Griff himself had taught them the dot-and-dash system. This recollection gave her an idea. Early next morning, grabbing a broom, Highland tapped a message on the floor with the tip of the handle.

K. C. Jones awoke from an unre-

refreshing sleep, brushed the sand from his clothing and bed, looked around for his razor and toothbrush, and discovered he had forgotten to bring them along. He felt like a bum in a Don Waters story. Overhead he heard a *tap-tap-tap*.

He listened. Again came the tapping. The old familiar Morse code! Picking up a bolt, he responded to Highland's message by pounding on the bottom of the floor. Thus communication was established. It provided the answer to a very urgent question K. C. had been asking himself:

"When do we eat?"

Up above, Highland told George, the Negro reporter, to serve breakfast in her room. This he did. As soon as he had deposited the meal on her table and left the room, Highland tiptoed over to the door and locked it. She put the food into a basket, added a monkey wrench as ballast, tied a string to the handle, and cautiously lowered it out of her window in front of K. C.'s door. Then she telegraphed K. C. with her broom handle.

Well, sir, as Silent Slim Roach would say, talk about manna coming right down out of heaven! K. C. reached out for that basket like it was an answer to prayer, and wrapped himself around the food in no time at all, while the gold special continued to burn up the rails in the direction of New Orleans.

After he had finished the nourishing breakfast, Highland pulled the basket back into her room, and everything was jake. K. C. amused himself by watching the wheels of the private car raise off the inside rail in rounding curves. He couldn't figure why he was hated by Highland's father.

Of course, he knew from reading the fiction in RAILROAD STORIES that a

grouchy official usually didn't have much time for a boomer courting his daughter. He was aware that Hardshell Higgins, for instance, who owned the Happy Valley Line, didn't want Goldenrod to marry the Engine Picture Kid, even though Hardshell and the Kid had one thing in common, both being engine picture fiends. But the Kid was a boomer when he began courting Goldenrod, whereas K. C. was not. At least, not at first.

The general manager of the Rocky Route Railroad had not only fired K. C. from that pike but had blacklisted him on every job he had gotten since. And all because K. C. had protected his father's good name at the time of the wreck at Big Top!

Reclining in the possum belly and ruminating on these things as they sped along the shining rails, K. C. vowed that at the end of this run he'd clear his own name without spilling the beans on his father. Yes, sir; he'd redeem himself, just like fiction heroes did in the yarns written by Searle B. Faires, the ex-op up in Winnipeg.

**B**LACK clouds milling around in the heavens reminded him of box cars rolling down a train yard lead in a hump yard. They were all loads—not an empty in the heavens. Lightning flashed, thunder boomed.

"Something is bound to happen," he muttered grimly. "Whenever E. S. Dellinger is about to reach a crisis in one of his novelettes the lightning flashes and the thunder booms, just like we're having now."

Sure enough, it did happen! While watching the black clouds, the boomer ex-hogger spied an airplane flying low over the gold special. Evidently the birdman was afraid of the storm. Looking closer, he recognized the plane

as belonging to the Rocky Route's deadly rival. She was the Tailspin Airway craft that was flying the other half of the gold bullion!

"I wonder what Brother Dellinger would do in a case like this?" K. C. asked himself. "Or Brandhorst or Don Livingston or any of the other boys who grind out railroad fiction?"

K. C. opened the door of his possum belly, and about that time the brakes went into emergency. If the car wheels hadn't been flattened before, they'd certainly be that way now. They looked like emery wheels; they were throwing out so many sparks. It reminded K. C. of John Johns in all his glory.

The cause was soon apparent. Their train had run into a washout. Alarmed, K. C. felt water flowing into his berth. If he didn't get out soon he'd be drowned. He did get out and started swimming to the engine.

Finding the cab deserted, he released the brakes, put the Johnson bar in reverse motion, opened the throttle and started backing out of flood water. Water had put out the fire, so K. C. took out a fusee, lighted it and soon had plenty of heat in the 998½'s fire-box.

The engine crew re-appeared, rather sheepishly, and took charge of their iron horse. They had jumped at seeing water on the track.

"No hoghead or tallowpot in a G. A. Lathrop story would have deserted," K. C. thought sadly, but again reminded himself that this was not literature but real life.

At any rate, the crew thanked K. C. as he scrambled back to his berth, and they got going again. Highland had been watching the whole affair. Her Scotch-heather eyes glowed with pride in K. C. Jones.

The gold special backed up and de-

toured over the Southwestern to El Pazo. As they were backing up they saw wreckage of the Tailspin plane heaped upon the ground. The bullion being transferred to a Road Hog truck. Evidently the foes of the Rocky Route Railroad were going to try to mush it through on the Old Spanish Trail.

AT that juncture Highland lowered down to K. C. two well-cooked T-bone steaks, some choice vegetables, a generous cut of cactus pie and a quart of milk. The disappearance of these viands caused Porter George to congratulate Highland on the improvement in her appetite. She didn't seem despondent any more, either. Undoubtedly the trip to California had done her a world of good.

This news greatly pleased her old man except that, being Scotch, he began figuring up the cost of additional food.

"If she keeps on eating this way I won't have any money to pay income tax," the G. M. remarked glumly. "We sure can't afford to let the airplane and truck interests get that fat contract."

After receiving orders to go over the Southwestern, he ambled over to the engineer and instructed him:

"Lay back the ears of the 998½ and pull the bridle off. The road's yours!"

Hearing this, K. C. wept inwardly. He wished the general manager were whispering these greetings into his own greasy ears instead of to that dumb hoghead. If only given a chance, just a little break, he'd show them plenty of speed—speed that would put to shame even the fast runs in John Johns stories.

When the train slowed up in passing through Albuquerque, E. S. Dellinger was at the station to see her go by. He highballed the hoghead with a wad of

paper. One sheet was whisked out of his hand by the breeze and right into the lap of Kansas City Jones.

K. C. looked at it curiously. It proved to be a page from Dellinger's latest novelette, "Harvey House Girl." He read the page, thinking all the while of his own Highland Mary.

On, on they went. The truck carrying the gold bullion tried to beat the 998½ to a crossing—as motorists often do!—but ran into the side of the train and almost knocked the possum belly from the bottom of the G. M.'s car.

"Just like a lousy truck driver!" K. C. exclaimed wrathfully. "No wonder Earle Davis attacked those buzzards in a recent railroad story."

The truck was badly wrecked, however, and the gold was transferred to a fast motorboat in the Rio River. The Rio at this point parallels the railroad track for 150 miles.

K. C. chuckled: "Here's where we gain on the motorboat!"

Even with a dumb hogger in the cab, the 998½ picked up speed and reached El Pazo only thirty minutes late. There she fueled up for a new dash for the New Orleans mint over the Rocky Route Railroad.

After making a couple hundred miles, the special train ran into a landslide. K. C. put on his dark glasses, emerged from his berth, and found the reason for the "defugalty," as Cupid Childs would say. There was a pile of rocks on the track. Around it were gathered Slippery Buck the conductor, and Highland and her old man, and a couple of railroad dicks.

"What shall we do?" the G. M.



"Write to the Lantern Department," a Gumshoe Suggested Acidly; but K.C. Picked up the Rocks One by One and Tossed Them Aside

asked, not recognizing Jones in the dark glasses.

"Write to Light of the Lantern department," one of the gumshoes suggested acidly.

The mighty K. C. gave the smart alec a scornful look. Without a word he picked up the rocks one by one and tossed them lightly from the right-of-way. Highland's eyes misted with tears of admiration at this noble deed.

While all this was taking place, the gold cargo was being transferred from the motorboat to a fast passenger bus. Evidently the Road Hog Bus Lines were going to show the railroad some fast running. It was a fight to the finish!

**T**HE special and the bus arrived at the quaint old town of Santone about the same time. Both were fueled up, changed crews and left about the same time—just as though they had somewhere to go and were eager to get there.

The riding time between Santone and Hewston wasn't going to be very long, the way the 998½ was dancing with sand in K. C.'s eyes. After crews had been changed at Hewston, K. C. rode the blinds out of town. Here they had got the punkest hoghead of the entire trip. He let the bus get ahead of him. K. C. could have died of ignominy.

Climbing on top of the fuel tank, he listened to the exhaust. Anybody could tell the hogger didn't know how to get speed out of the 998½. K. C. saw the bus drive up on a highway crossing ahead of them and stall on the main iron. The hoghead big-holed the brake valve. Then he leaped out the right side of the cab, and the tallowpot out the left.

The bus driver finally got his motor

started. He slid off the track in low gear just as the special whizzed by. K. C. ran down in the cab, threw the Johnson bar ahead, snatched the throttle wide open and started releasing the brakes. In a few minutes he was passing the Road Hog's prize buggy.

However, he was kept busy firing the engine and running it, too. He didn't have any orders, as the hoghead who had jumped took them along with him. All K. C. knew was he had rights over all trains and they had better be in the clear. What more could any engineer ask for?

Meanwhile, back in the train, the conductor knew well from the way they skyrocketed along that they were now making the best time in the history of the road, but he sauntered over to the engine. Climbing down the ladder on the fuel oil tank, he only saw one man in the cab. This man was neither the hoghead nor tallowpot he was supposed to have. To him the famous K. C. Jones was a total stranger, and he asked:

"How come? Where's my engine crew?"

"They jumped off back yonder when they thought they were going to hit the bus," K. C. explained nonchalantly.

"That crew was no good anyway," stormed the conductor. "My flagman, Santa Fe Cactus, is an ex-oil-burning fireman off the Old Horny Toad. I'll send him over to fire for you and maybe we can beat the bus to New Orleans."

As soon as "Santa Fe" Cactus arrived and had everything lined up, K. C. whistled for a jerkwater town. Highland highballed him. The speedometer on the 998½ only registered up to 85 miles an hour. K. C. had the pointer against 85 and nobody knew how much faster he was going.



The irate general manager now had something up in his neck and it wasn't his Adam's apple. When a locomotive runs about 30 miles an hour faster than it's geared up to run it gets to crow-hopping or nose-diving. The 998½ was doing both. She was just about shaking the lead out of the counter-balances in her drivers.

**A**HEAD of them was a tremendous light like an oil field aflame. As they approached K. C. saw it was a forest fire. He slowed down and stopped at the edge of the woodland.

The G. M. gave orders to back up and wait until the fire burned out, but after backing about a quarter of a mile he saw the fire was burning across the track behind them. They were trapped by the fire, with nothing to do but go ahead, so they highballed K. C.

"Wonder what a Bill Hayes hero would do in a case like this?" he mused.

They hit the fire ahead, going 60 miles an hour. K. C. turned on the cold water squirt hose, spraying the inside walls of the cab. The steel cab was so hot it would fry the cold water like a hot stove. If hell should ever run short on heat, the inside of this engine cab would make a fine annex.

The 998½ was making 70 per, when K. C. saw live coals igniting fuel oil that had sloshed out on top of the fuel oil tank. He took the squirt hose and kept this fire put out as fast as the wind blew it from the tall tree tops.

If the fuel oil tank should catch fire they'd all perish. Worse than that, the precious gold they were hauling would melt and run away.

While K. C. was keeping the cab cooled off and putting out the fire on top of the tank, Santa Fe was overcome with heat. The Horny Toad veteran lay on his back in the deck.

When he come to, his uniform was three sizes too small.

K. C. had been whistling all along, trying to get a highball out of Highland Mary. He wanted to see if everything was all right back there.

It was! The train crew, guards and gumshoes had crowded into the private car because it was air-cooled. The cooling machinery did its best trying to keep the car at 70 degrees, but finally gave up in despair and the temperature rose to 120. Highland Mary was talking to the conductor.

"If dad, who hates K. C. so bad, could run this railroad like K. C. runs an engine," she said, "he wouldn't have to be borrowing money from the R. F. C."

K. C. was now heading into New Orleans terminal in a whirlwind of glory. Finally he stopped the train. The race was won! He collapsed on the seat-box and was taken off the engine, put in an ambulance. Highland gave orders to take him to her home.

A couple of days later the bus finally limped in with its quota of gold. But the Rocky Route Railroad had already got the contract. Incidentally, the gumshoes received reward money for the bandits they had caught in the ravine.

After K. C. got better, pretty red-headed Highland Mary informed her father that she was going to marry him—"Even if we both have to go on the tramp for the rest of our lives," she declared firmly.

The G. M.'s heart melted. He reached out a long arm, pulled Highland over to him and said:

"Daughter, you won't exactly be on the tramp, but Kansas City Jones will be the new traveling engineer. I have re-instated him with full seniority rights. We need a hoghead like him on the Rocky Route Railroad.

# The Month of April in Railroad History

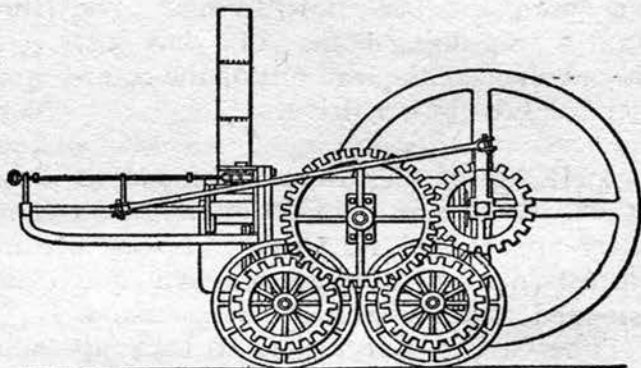

Richard Trevithick, inventor of the first steam locomotive to run on rails, was born in England April 13, 1771, and died April 22, 1833. His Pioneer Engine (shown here) doesn't look much like her modern descendants

**I**NTERESTING events in railroad history are listed here. If you want to know what happened on your birthday or any other day of the year, watch this almanac. We plan to carry it on for twelve consecutive months and make future issues even more complete than this first one. Readers are invited to send us important railroad dates, giving the actual day, month and year. Dates for the June almanac must be received before March 15th.

## April 1

1821—Construction work begun on America's first railroad. (This road, extending 4 miles from granite quarries at Quincy, Mass., to site of Bunker Hill Monument, was built to transport huge granite blocks used in erecting the monument.)

1845—First tariff on telegraph messages goes into effect. (Before that, service was free. On the first day, April 1, only one cent's worth of business was done; one cent for four letters. On the seventh day, 60 cents' worth of business was done. On the ninth day, \$1.04. This service was under control of Postmaster General. Income was so slim that the Government refused to buy permanent rights to the telegraph invention for \$100,000, and it was left to private capital.)

1876—Great Northern Ry. of Ireland incorporated. (Now 917 miles long.)

1879—David A. Crawford, president of Pullman Co., born at St. Louis, Mo.

1882—South Shore Ry. in Canada opened from St. Lambert to Sorel, Quebec.

## April 2

1831—Cumberland Valley Railroad and the Philadelphia & Delaware Counties Railroad (now both part of P. R. R.) chartered in Penna.

1853—N. Y. Central Railroad organized under N. Y. State law by amalgamation of the Albany & Schenectady; the Schenectady & Troy; the Utica & Schenectady; the Syracuse & Utica; the Syracuse & Utica Direct; the Rochester & Syracuse; the Buffalo & Lockport; the Mohawk Valley; the Rochester, Lockport & Niagara Falls, and the Buffalo & Rochester.

## April 3

1872—American Fork Railroad, 22 miles, narrow gage, incorporated in Utah to connect town of American Fork, on Utah Southern Railroad, with Sultana. (Now abandoned.)

1874—King's Mt. Railroad, 5-foot gage, 22 miles in South Carolina, is merged with the 3-foot-gage Chester & Lenoir Railroad; gage of entire road is made 3 foot. (Now Carolina & N. W., operated by the Southern.)

1882—Jesse James, most picturesque of all train robbers, never captured, is shot and killed in his hilltop home at St. Joseph, Mo., by Bob Ford, a member of his own gang.

## April 4

1833—Philadelphia & Reading Ry. chartered in Penna.

1852—Erie & Kalamazoo Railroad incorporated in Ohio; the first railroad in section then known as the Northwest Territory. (Now part of N. Y. C. Lines.)

1868—Pittsburg & Castle Shannon Railroad incorporated in Penna. Part of the road was already built by the Pittsburg Coal Co. with gage of 3 feet, 4 inches, to which the new company adhered. (Name later changed to P., C. S. & Wash.; now part of B. & O.)

1885—Passenger service inaugurated between Winnipeg and Moose Jaw, Canada.

1922—Work begun on one of world's largest railroad fills, located on the Reading's Catawissa branch near Ringtown, Pa. (This fill, 3,340 ft. long, 116 ft. high, containing 1,352,613 cubic yards of material and costing \$1,200,000, was completed Nov. 19, 1927.)

#### April 5

1852—Lackawanna & Bloomsburg Railroad (now part of D. L. & W.) chartered in Penna.

1862—Charles H. Hix, of Norfolk, Va., president of Virginian Ry., born in Virginia.

1886—U. S. Interstate Commerce Commission created by Congress in "Act to Regulate Commerce."

#### April 6

1933—Last train, a freight, runs on Waynesburg & Washington Railroad in Penna.; 28 miles, narrow gage, built in 1877.

#### April 7

1839—First German long-distance railway opened, 71 $\frac{3}{4}$  miles between Leipzig and Dresden, including Germany's first railway tunnel, 1683 ft. long, near Oberau. (Leipzig station is still largest in Europe.)

1880—Michigan Railroad (Lansing to Indiana state line, 109 miles) merges with Chicago & Grand Trunk.

1914—Cy Warman, assistant to President E. J. Chamberlin of the Grand Trunk, dies in Chicago. Was D. & R. G. engineer, also poet, author and editor. His greatest poem was "Will the Lights Be White?"

#### April 8

1852—North Pennsylvania Railroad (now part of the Reading) incorporated in Penna. under the title Philadelphia, Easton & Water Gap.

1853—Fort Wayne & Chicago Railroad (now part of P. R. R.) chartered in Indiana. (Incorporated in Illinois on Feb. 5, 1853.)

1874—Parker & Karns City Railroad, narrow gage, 10 miles in western Penna., opened to traffic. (Now part of the B. & O.)

1876—H. A. Scandrett, of Chicago, president of Milwaukee Road, born at Faribault, Minn.

1879—Sandy River Railroad (2 ft. gage) chartered in Maine; originally Farmington to Phillips, 18 miles.

1884—Birth of Charles W. and Jesse B. Speck in Tennessee. The only twins known to have made up an engine crew on the same locomotive. Speck twins were engineer and fireman on Mo. P. passenger train, Poplar Bluff, Mo., to St. Louis.

1933—Engine No. 5436 hauls P. R. R. "Broadway Limited" on its final steam-powered run out of N. Y. City.

#### April 9

1914—First through train from Winnipeg, Man., reaches Prince Rupert, B. C., Canada.

#### April 10

1854—Construction begins on Brooklyn City Railroad in New York; 4-wheel horse cars used.

1895—Oliver Perry escapes from Matteawan (N. Y.) Hospital for Criminal Insane. Perry, ex-brakeman of N. Y. Central, robbed the same express train on 2 different occasions. (Was recaptured April 16, 1895, and died in a prison hospital Sept. 10, 1930.)

1902—Formation of the oldest of the various holding companies to take over control of a big railroad in U. S. Pool consisting of John W. ("Bet You a Million") Gates and his son Charles and Edwin Hawley, all noted stock market speculators, acquires control of Louisville & Nashville by secretly buying over half its capital stock.

#### April 11

1848—Ohio & Penna. Railroad (now part of P. R. R.) chartered in Penna. (Chartered in Ohio on Feb. 24, 1848. Opened to public April 11, 1853.)

1883—Standard time plan presented to railroad officials in General Time Convention at St. Louis by William F. Allen, who reports there are at least 53 different standards of time in U. S. and Canada. (Standard time cuts them down to 4.)

#### April 12

1873—A. F. Whitney, president of Brotherhood of Railroad Trainmen, born at Cedar Falls, Iowa.

1910—Four big railroad Brotherhoods dedicate their joint Home for the Aged and Disabled Railroad Employees of America at Highland Park, Ill.

#### April 13

1771—Richard Trevithick, inventor of first steam locomotive to run on rails, born in England. (His locomotive made her famous trip Feb. 24, 1804; used thereafter as a stationary engine.)

1838—Old Colony (New Bedford & Taunton) Railroad incorporated in Mass. (Now part of the New Haven.)

1846—Pennsylvania Railroad chartered in Penna.; \$7,500,000 capitalization. Originally owned by State of Penna.

1849—Panama Railroad Co. gets a charter in N. Y. State to build across the Isthmus of Panama. (This road, since 1904, is being operated by U. S. Govt. at a profit, according to latest annual report, \$2,000,000 in dividends being deposited in U. S. Treasury for fiscal year 1934.)

1862—Andrews railroad raid; 22 Yankee spies led by James J. Andrews of Flemingsburg, Ky., seize Confederate train on the Western & Atlantic (now part of N. C. & St. L.) in daring plot to cripple that road, on which supplies are being rushed to Confederate Gen. Beauregard (later president of the New Orleans, Jackson & Great Northern Railroad, now part of the Illinois Central). After exciting chase in the "General," the captured locomotive, all 22 Yankees are taken.

1869—First Westinghouse air brake patent.

1917—"Diamond Jim" Brady, millionaire spendthrift and super-salesman of railroad supplies, dies of overeating one week after U. S. enters World War. Had 200 suits of clothes and 16 complete changes of jewelry. Office was at 170 Broadway, N. Y. City. (Present office of RAILROAD STORIES is 280 Broadway.)

#### April 14

1836—Eastern Railroad (now part of Boston & Maine) chartered in Mass.

1871—Incorporation of Ontario & Quebec Ry. (now operated under lease by C. P. R.).

1878—Angus D. McDonald, president of Southern Pacific, born in Oakland, Calif.

1888—Four-story Brighton Beach Hotel at Brighton Beach, N. Y., owned by Long Island Railroad, is jacked up, 24 parallel railroad tracks are laid under it, 120 flat cars are slid under it, and hotel is moved 595 feet by 6 locomotives fastened to cars by 2 miles of rope. Old location was being undermined by ocean.

#### April 15

1857—Construction of West Jersey Railroad (now part of P. R. R.) completed between Camden, N. J., and Woodbury, N. J.

1869—Montrose Railroad, narrow gage (now part of Lehigh Valley) incorporated in Penna.

1880—Santa Fe line built to Albuquerque, N. M.

1911—Construction work begins on National Rys. of Haiti.

1933—Farewell excursion train on the 14-mile Woodstock Railroad, between Woodstock and White River Jct., Vt.

#### April 16

1836—Nashua & Lowell Railroad (now part of B. & M.) and the New Bedford & Fall River Railroad (now part of the New Haven) are incorporated in Mass.

1853—The "Toronto," first locomotive built in Upper Canada, completed at James Good's foundry in Montreal.

#### April 17

1821—Construction of pioneer English railway, Stockton & Darlington, authorized by Parliament. (This line, which issued world's first rail timetable Oct. 10, 1825, is remembered today for its quaint custom of having man on horseback ride ahead of train to see track was kept clear.)

1836—One of the earliest railroad accidents; axle broken in train on Manchester & Liverpool line, train thrown down 20 ft. embankment, no one killed.

1855—John M. Horan ("Soda Ash Johnny") gets his first rail job—on the Milwaukee & Mississippi (now part of the Milwaukee Road)—loading fuel on wood-burning engines. (He was born Jan. 23, 1838, and is still in service on the Milwaukee; world's oldest active railroad man.)

1881—A. N. Boyd, Canadian National Rys.

foreman of engines, 1921-8, born at Jonesboro, Tenn. (See "Famous Engineers," Sept., '33, RAILROAD STORIES.)

1893—Illinois Central station at Park Row, Chicago, is opened with impressive ceremony.

1893—Engine "John Bull," first locomotive used on the Camden & Amboy Railroad (now part of P. R. R.) in 1831, is temporarily put back into service to haul special train to Chicago World's Fair.

1893—Canadian Pacific Ry. carries an 11-ton cheese, said to be the world's largest, from Perth, Ont., to Chicago for World's Fair.

1933—Sandy River Line in Maine, America's longest 2 ft. gage railroad, suspended July 8, 1932, resumes on limited schedule.

#### April 18

1848—Narrow-gage Billerica Branch Railroad chartered in Maine. (Now abandoned.)

#### April 19

1819—Oliver Evans, "Father of American Railroading," dies in N. Y. City, age 64. (See p. 131.)

1851—Albany & Susquehanna Railroad (now part of D. & H.) incorporated in N. Y. State.

1873—Boston & Providence wreck at Richmond Switch, R. I.; 7 killed.

1878—W. R. Morley, an engineer in charge of construction for A. T. & S. F. Ry., and 7 other armed men seize Grand Canyon of the Arkansas, defying rival D. & R. G. to build through it. Most dramatic episode of famous "Canyon War."

1905—Day after San Francisco earthquake, Southern Pacific Railroad begins gigantic task of stopping Colorado River flood and saving the fruit-growing Imperial Valley of Calif.

#### April 20

1848—Chebaco Branch Railroad Inc. in Mass.

#### April 21

1855—The "Des Moines," first locomotive to cross Mississippi River, crosses on the new Chicago & Rock Island bridge at Davenport, Iowa.

1863—Commodore Cornelius Vanderbilt, railroad magnate, one-time president of N. Y. Central, gets franchise to run street cars on Broadway, N. Y. City. (N. Y. Central streamline locomotive is named for him.)

1868—Ground broken for Woodstock Ry. in Vt. (abandoned in 1833).

1910—Six convicts escape from Leavenworth Penitentiary, Kansas, by using Union Pacific switch engine to batter open the slowly-closing gates. (One of the 6, Frank Grigware, U. P. mail train robber, was not recaptured until March, 1934, while living as respectable citizen under another name in Edmonton, Alta., Canada.)

#### April 22

1833—Richard Trevithick, pioneer locomotive inventor, dies in poverty at Dartford, England.

1853—Erie & Kalamazoo Railroad incorporated in Michigan Territory.

1842—Erie & North-East Railroad, 6-foot gage (now part of N. Y. Central) chartered in Penna.

1851—New York, Lake Erie & Western Ry. (now part of the Erie) completes its line to Lake Erie.

1886—Costa Rica Rys., Ltd., registered in England. (Present mileage 190.)

1880—First big land rush to Cherokee Strip (in what is now the State of Oklahoma), in which the Santa Fe Ry. plays an important part by carrying trains jammed to the roof with homesteaders.

#### April 23

1831—Opening of Ponchartrain Railroad, in Louisiana—first railroad chartered west of Allegheny Mts. Cars originally drawn by horses. (Abandoned March 15, 1932.)

1834—Chauncey M. Depew, late president of N. Y. Central, born at Peekskill, N. Y.

1846—Lehigh Valley Railroad chartered in Penna. (See page 88.)

1886—Cleveland & Marietta Railroad, 187.5 miles, acquired by the Wheeling & Lake Erie.

1900—Norfolk & Carolina Railroad (which merged with the Wilmington & Newbern in 1897) and Atlantic Coast Line Railroad of S. C. (which merged with the Northeastern Railroad in 1897) consolidate with the A. C. L. Railroad of Va., thus forming the present Atlantic Coast Line.

#### April 24

1827—B. & O. Railroad organized at Baltimore, Md., with Philip E. Thomas as first president, Geo. Brown, treasurer, and 14 directors, 2 of them representing City of Baltimore.

1832—New York & Erie Railroad (now the Erie) incorporated in N. Y. State.

1834—Long Island Railroad (now part of P. R. R.) chartered in N. Y. State.

1837—Germany's first railway, "Ludwigsbahn A. G.," begins service on 5.7 miles, Leipzig to Alten. (This road is still in existence; since 1926 its tracks have been used for a tramway.)

1878—N. Y. & Erie Railroad, 465 miles, acquired by the N. Y. L. E. & Western.

1904—Sergt. Wm. Pittenger, one of the 22 Union spies who participated in the Andrews railroad raid, dies at Falbrook, Calif. In April, 1862, he was captured by the Confederates, and on March 17, 1863, he was paroled; later he wrote a book on the raid.

1932—Running time of N. Y. C. "Twentieth Century Limited" between New York and Chicago cut from 20 to 18 hours.

#### April 25

1831—New York & Harlem Ry. (now part of N. Y. Central) chartered in N. Y. State as a steam road extending from Prince Street in the southern

part of N. Y. City to Chatham Four Corners (beyond Croton, N. Y.).

1903—Quebec Oriental Ry. (now part of C. N. R.) incorporated in Quebec, Canada.

#### April 26

1875—Harry R. Kurrie, president of Chicago, Indianapolis & St. Louis and Kentucky & Indiana Terminal railways, born at Paoli, Ind.

1925—First trip of B. & O. "Capitol Limited."

#### April 27

1791—Samuel F. B. Morse, inventor of telegraph and well known artist, born in Charlestown, Mass., son of clergyman.

1854—Penna. Legislature tries to get rid of its unprofitable state-owned Penna. Railroad main line. Passes a law authorizing its sale, but no purchaser can be found.

1861—As Civil War emergency measure, Thomas A. Scott, P. R. R. vice president, is appointed director general of all railways and telegraph lines between Washington and Annapolis, Md.

1873—Ground broken at San Diego, Calif., for Texas & Pacific Ry. (but the road was never built that far).

1873—Worcester & Shrewsbury Ry. (narrow gage, now part of B. & M.) organized in Mass.

#### April 28

1847—Portland, Saco & Portsmouth Ry. in Maine leased to the B. & M. for term of 99 years.

1853—Ponchartrain Railroad in Louisiana authorized to build line to Mobile, Ala.

#### April 29

1899—Northern Pacific train in Idaho seized by striking miners who use it to transport powder to blow up mine buildings.

1900—Casey Jones (Harry Luther Jones) dies in Illinois Central wreck near Vaughan, Miss. (World's best known railroad song, "Casey Jones," is based on that wreck.)

#### April 30

1860—Jeffersonville Railroad, 84 miles, is merged with the Jefferson, Madison & Indianapolis. (This road is remembered today largely because it was the scene of America's first big organized train robbery, perpetrated by Reno Gang.)

1888—Interoceanic Ry. of Mexico, Ltd., registered in England to acquire 99-year lease from Mexican Govt. for about 250 miles of railway then completed and about 250 to be built.

1916—Montreal & Southern Counties Ry. reaches Granby, Quebec, Canada.

1917—Patricia Bay Subdivision of Canadian Northern (now part of C. N. R.) opened from Victoria, B. C., Canada.

1933—Running time of "Twentieth Century Limited" between New York and Chicago cut from 18 to 17¾ hours.

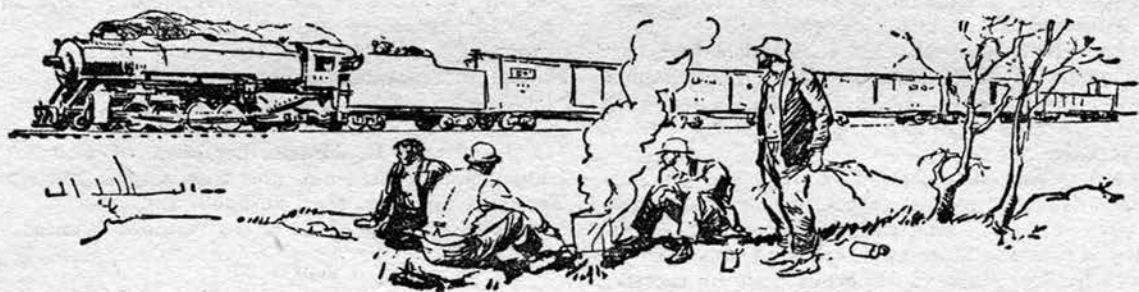

*To Old Bill Danforth, Skipper on  
the Gulf Lines, Every Hobo Was a*

# D a m n h o b o

By E. S. DELLINGER

Ex-Brakeman, Mo.P. and Frisco; Author of "Harvey House Girl," etc.

**O**LD Bill Danforth, Gulf Lines freight conductor, hated hoboes worse than hell hates holy water. He had been hating them for more years than most men on the Creeping Shadows Division could remember.

It happened like this: on a dark night forty years ago he spiked down into a boxcar load of them to collect. It was his right—if he was big enough. Bill had always thought he was big enough. This time he wasn't. Instead of digging up, they broke his jaws, knocked out his teeth, caved in his skull, and kicked him off for dead.

When he returned to work a year later, he declared war on the hobo kingdom. It was not new, this war between bum and brakeman. It had been going on ever since the first rail was laid and wheels run over it. To most men it is a game. To Bill Danforth it was a mania.

The night was never so dark, nor the

wind so wild, nor the tops so slick with glare ice, but that at sight of a moving shadow he would tear out of his warm caboosie, risk death, vowing death to the "damnhoboes."

Forty years, he boasted that the "damnhobo" didn't live who could ride his train — and made good the boast. Men predicted he would come to grief, would fall off a reeling freight, or tackle another gang who refused to run. And as the years passed, and hate for hoboes made him the meanest conductor who ever quilled a wheel report, more than one disgruntled brakeman secretly hoped it would be soon.

While the home guards predicted, the finger of Fate fixed upon Terry O'Brien. Red-headed, freckled, a hobo kid from God knows where, Terry rode the blind of No. 9 into Blaisdell, and jumped off into the arms of a pair of railroad bulls.

They kicked his back and slapped his front and headed him for the hoose-

gow. But Fate had other plans. As they passed the yard office, Big Bill Sears, Division Superintendent, looked the kid over, grinned a couple of times, and made a brakeman out of him.

Danforth pawed the air and tore up the cinders.

"If you ever call that scum for my crew," he raved, "there'll be a damn-hobo in the hospital, an' a callboy in the hearse."

For three years Terry was not called on Danforth's crew. He never knew why. Then, one night, he danced with Danforth's Betty. She fanned his cheek with perfumed breath, and whispered the wish that "poor Daddy could get just one *good* brakeman who knew what to do and did it."

Until now, Terry had never spoken to the old hobo chaser. Had he spoken now, Fate might have been thwarted in its unerring purpose. He didn't.

Three days after the ball, the rear end job on Old Bill's crew was "advertised." In fact, both jobs on Old Bill's crew had stayed "advertised" most of the time for forty years. Ignoring friendly tips, Terry remembered only the wistful wish of blue-eyed Betty, and signed for the run. He got it.

**I**T was September. Midnight lay on the land of Creeping Shadows. Bitting east wind tamped dense wraiths of fog among acres of freight cars in the Blaisdell yards.

His heart rapping his slats at a hundred a minute, Terry hurried through fog and darkness, answering his first call to brake behind for Old Bill on No. 36.

Out of the fog grew a yellow light. Filtering through dingy unwashed windows, it fell in blurred oblongs on the wet red walls of a freight car.

Terry swore. He had come early tonight, expecting to be first in the caboose. Old Bill Danforth was already there!

A hundred and eighty pounds of "good brakeman" fell up the forward platform. The caboose swayed. Terry flung open the door.

The shriveled conductor, skull cap on bald pate, was at the homemade table, back to the door. He did not turn. Terry stopped, wondering if the old man were hard of hearing. But he slipped his gauntlet from his bronzed hand and strode forward.

"Name's O'Brien," he said. "Terry O'Brien."

Old Bill glowered fiercely up. His sagging saucer-shaped jaws tightened on silver wires. His gold teeth clacked, and his eyes gleamed over horn-rimmed spectacles.

"The hell it is!"

Terry's grin froze. He did not withdraw the hand. He stood gulping and staring at a conductor who refused to shake. Maybe Danforth did not understand.

"I've jist signed up for this run, Mr. Danforth," he explained.

Old Bill kept looking at the hand as if he would spit in it. Neither of them moved or spoke for a second. Then:

"What the hell do you expect me to do? Give yuh a dollar?"

"Give me a—give me a—give me a—dollar!"

"Yes. I jist heard they'd signed a damn-hobo on my crew. Thought maybe—"

Understanding came to Terry. Long ago he had forgotten how he had come into Blaisdell on the blind.

Beneath him the caboose was reeling. He took a step forward, fist drawn. At one blow he could have

driven the sneering shriveled face through the way-car wall.

"You—you damned old son—" He hushed abruptly.

Danforth leered at him.

"Finish it! You overgrown lobster! Go right ahead! I've heard it before. It's the only epithet a damn hobo knows."

Terry did not finish it. He was recalling a night at the Trainmen's Ball, and a perfumed breath fanning his cheek, and a wistful voice whispering:

"I do wish Daddy had a good brakeman, one who—"

The big fists relaxed, fell to his sides.

"Listen, Mr. Danforth," he croaked. "I've signed up for this run. I aim to stay with it."

"Like hell you will!" screeched Danforth. "Like hell you'll stay! The hobo don't live who can ride my train, much less ride my cupola an' read my orders. Why, you impudent upstart, I'm goin' straight to the office! I ain't goin' to move a wheel till they give me a brakeman instid of a damn hobo!"

He surged past Terry, and stumbled through the fog toward the yard office, roaring threats and curses.

Terry fully expected him to bring another brakeman to the caboose when their train pulled by the yard office. He didn't, neither that night, nor for many nights to come.

**T**ERRY scrubbed dirty floors, washed dingy windows, and put in new seat cushions. Old Bill did not seem to notice. In utter silence he would swing up the platform, make out his reports, climb into the cupola to smoke and watch his train. He never spoke another word to his new brakeman until that night at Creeping Shadows.

The Creeping Shadows country is wild. Its rugged mountains are clad in gnarled oak and hickory and black-jack. Its steep-walled valleys are matted with dogwood, and thorn bush, and wild grape, and Virginia creeper.

Under the tangled mass rattlers sing and copperheads hiss, and cottonmouths crawl in black ooze and slime. Through its darkened glens wild deer slink in the dawn; down its game trails panthers scream in the darkness, and men wilder than these seek refuge from a law which they have outraged.

Its denizens had fought the coming of rail and civilization. They hated it because it interfered with their liberty and license. They missed no flimsy pretext to strike at the steel and the men who ran it. More than once Big Bill Sears had cautioned Danforth.

"Chase hoboes if you will, but not in the Creeping Shadows."

About a month after Terry came on the car, Danforth's crew caught a drag out of Fort Jones for the south. They had sixty cars, empty boxes and flats, with loads of coal and lumber and scrap iron sandwiched between. In the late afternoon, they climbed the grade past Black Mountain, crawled through the long tunnel, and wound down the grade toward the town of Creeping Shadows.

It was dark when they stopped at the tank. A drizzle was falling. Terry hit the cinders. He carried a hickory club and a skeleton frame lantern. He was going to look over his train.

A second behind him Old Bill Danforth hit the cinders. He carried a hickory club and a skeleton frame lantern. He was going to hunt hoboes. Terry walked rapidly, flashing his lantern under the cars, watching for broken wheels and dragging brake beams. He saw two pairs of shoes on



the opposite side. He did not stop to investigate. He kept on going until he met his head brakeman thirty cars from the caboose. They exchanged a word of greeting.

"How're they runnin'?" asked Terry.

"O.K.," returned the buddy. "How're you an' Bill gittin' along?"

"Still arguin'," grinned Terry.

The two brakemen crossed the train and started toward their respective stations. Terry recalled the two pairs of shoes he had seen. He kept looking for their owners. He did not see them. Even with where they had been, he heard voices in an empty boxcar.

"You git the hell off this train an' stay off," Danforth was saying. "We ain't hauling no damnhobo on trains I run."

"You can't kick me off, you shriveled sardine," another voice was bellying. "I'll cut out yore yaller liver an' feed it to the buzzards."

"You git off!" Old Bill screeched. "The hobo don't live who can ride my train!"

Terry went back to the caboose. Ever since he had been on the job, he had looked after the train and let Danforth chase the hoboes.

He caught the caboose as it came by, and waited on the platform as usual until the conductor caught on. The caboose ran past the place where he had heard the argument. He looked out. No light was in sight. He began to grow uneasy. Maybe Danforth had found his match. Maybe— He dropped to the bottom step, intending to take one more look and then pull the air. As he hit the step, he heard the conductor yell:

"Git outa my way, dammit! I'm comin' up!"

Terry fell back on the platform. Old

Bill caught the railing and swung up beside him. The guards of the skeleton frame lantern were broken. The brake club had blood on it. Old Bill had a missing tooth and a black eye.

THE conductor volunteered no information. Terry asked no questions. He got the spare lantern out of the locker, lighted it and adjusted the wick. Old Bill set the broken one in the floor for him to put away, jotted down the time on the delay sheet, and climbed to the cupola to smoke and watch the train. He rode into Blaisdell without speaking.

This was on Friday evening. On Tuesday night they caught the Kansas City Merchandise. They were standing side by side on the rear platform when they pulled by the office.

Big Bill Sears swung up the platform. He carried a flint rock with a scrap of cheap white paper tied to it. He was chewing the end of a dead cigar. He squinted at Danforth.

"Have you been chasin' hoboes down around Creepin' Shadders lately?" he rasped.

Danforth looked at Sears, then at Terry.

"Yeah," he responded in surprise. "I kicked off a couple there last week. Has this damnhobo been—"

"You big fool!" roared Sears. "Read that!" He thrust rock and paper into Danforth's hand. "It was tossed into my window last night."

Danforth held the paper to his lantern. His face was a poker mask. When he had finished, he returned the paper to Sears. Sears gave it to Terry.

U ar going to have a nuther rek. It is going to be a big rek. I am going to kill a cornducter. An git even with ur railrod. He cant beet me up an thro me offn a dam tran an live to brag about it.

In the place for signature was the crudely drawn picture of a coiled rattlesnake.

Terry looked at it curiously. He did not need to ask whose it was. Electric chairs of three states had waited long for "The Rattler." He handed the message to Sears. Sears turned on the conductor.

"I told you to lay off that Creepin' Shadders gang," he boomed. "Looks like you're headed hellward on a drag where there ain't no air."

Danforth said nothing. Sears dropped off. The two men went into the caboose to read orders and watch their train.

**T**HE next days were uneasy ones. Railroad men often looked over their shoulders. The Creeping Shadows had struck before. Rumors soon flitted about that it was striking again. Around the outlaw capital, trainmen clung close to cab and cupola, peered cautiously into dark corners, and breathed more easily when dawn came.

Old Bill Danforth went about his business as if nothing had happened. He did not speak to Terry. He chased hoboes as relentlessly as ever. Terry marveled at the old man's callous unconcern.

Sunday night they were called out of Blaisdell on No. 36 at 9.40. A fierce storm was brewing over the Creeping Shadows hills. Pink lightning flared in the purple heavens. The head brakeman laid off sick. Terry had a hunch that he, too, should lay off sick. He did not play his hunch, but took the call.

He went to the yards and checked their train. Next the caboose were two cars of merchandise for the mines at Southport, where rails plunge through the Creeping Shadows tunnel. That

was nothing new. Every Sunday night for years the Merchandise had short loads for Southport.

Ahead of the Southport cars were seven loads for the Iron Mountain connection in Fort Jones. Terry looked at them only to see that the hand brakes were released and the hoses coupled.

Ahead of them was a system box for Joplin. He looked twice at it and looked again. It had big red cards on the side and ends. Terry knew that car was a load of dynamite for the mines. He had often ridden trains hauling high explosives, but in this one he saw possibilities which sent goose-pimples trickling like cold sweat down his spine. He laughed shortly and went on.

The two ahead were machinery and ore. The third was a flat-bottomed coal car. On this car the brake was set. Terry climbed up to release it. It was loaded to a depth of eighteen inches with lengths of gas pipe. In the rear end was a pile of straw, where hoboes had had a bed.

Danforth was late to work. He looked old and tired. For the first time in five weeks he appeared to remember he had a hind brakeman. Without looking at Terry, he asked in an apologetic tone:

"Have you got a gun?"

Terry laughed mirthlessly.

"Hell, no. I ain't no bull. I'm a brakeman."

With a shrug, Old Bill went to the office. He caught the caboose as it pulled by and handed Terry the orders. One of them informed him that No. 8 would run three hours late from Blaisdell to Fort Jones. No. 8 was the "Flying Bee," crack train of the system.

Terry remembered that Superintendent Sears was taking a general manager and some lesser officials north on the train tonight. He read the

order, looked at his watch, glanced at the time card, and reckoned mentally that they would let the Bee by them at Creeping Shadows if all went well.

They did not let the Bee by at Creeping Shadows. The order board was out. The engineer took the train up the main line. While Danforth went into the office, Terry looked around his train. On the opposite side, even with the car of pipe, he saw three pairs of shoes. They were heavy shoes. He did not stop to investigate.

At the middle of the train he met Chink Summers, the head brakeman, and turned back toward the caboose. It was raining now, and the lightning which earlier had flared and shimmered came no more. When he got to the pipe car, the shoes were not there. He looked all about. No one was in sight.

Soon the train pulled away from the tank. Terry caught the caboose. The door was open. He remembered distinctly that he had closed it. He looked within. On the floor was a piece of cheap white paper tied to flint rock. He picked up the paper and read the crude scrawl:

**I strik to nit. Damn yor sol.**

In the place for the signature was the crude drawing of a coiled rattlesnake.

**T**ERRY gripped the flint rock and ran to the rear door. He did not expect to see Danforth's lantern. He was mistaken. As he went out the door, Danforth swung up the rear platform. He had a single sheet of green tissue and a yellow message slip. He handed them to Terry.

Scarcely realizing what he did, Terry grabbed them and shoved his paper into Danforth's hand.

"Read that!" he chattered.

The old man held the white sheet to the light, read the scrawl and tossed it contemptuously off into the darkness.

"To hell with 'em!" he muttered.

They remained on the platform until they had passed the switch. The regular *wham-wham-wham!* of the exhaust on the helper engine coupled to their caboose rang in their ears. Finally Terry went inside and read his order.

**Order No. 21 annulled. No. 8, engine 509, run four hours late Blaisdell to Fort Jones.**

Then he read the message:

**To C & E, No. 36. Stay at Southport for No. 8, acct. Black Mountain blocked with cars.**

He hooked both order and message and climbed into the cupola. Old Bill was already on the other side. They watched the headlight of the helper play over the tops of the reeling cars. Not a moving shadow showed.

All the way up the hill Terry kept wondering about that last warning. He shuddered every time he remembered that he had to do some switching at Southport.

They headed into the mile-long passing track at the top of the Creeping Shadows Mountain. From the south end of this passing track a two-mile spur swung east around the mountain to the Southport mines.

Ordinarily the crew took the Southport cars over with the helper engine. Tonight the helper was returning immediately to Creeping Shadows for No. 8. When it cleared Chink Summers brought the road engine down the main line, and headed it in against the caboose.

Terry cut off two cars and the caboose, turned them into the mine track,

and rode away around the mountain. Old Bill did not go with them. He stayed with the train. The last Terry saw of his lantern he was heading toward the deserted office to deposit way-bills in the box. At sight of the speck of light flitting through the darkness, Terry shivered.

Rules required crews to place the two mine cars at the platform for unloading; but when Terry and Chink arrived they found both the platform spur and the mine spur full of cars. After a paint-scorching essay on the dumbness of officials who made through freight crews spot short loads, Terry did the only thing he could do. He coupled into the cars at the platform and backed down to Southport with three of them. These three he shoved into the passing track, a quarter mile below where he had left the rear end of his standing train.

**H**E did not return to the mines with the engine. He sent Chink. He set brakes on two of the cars he had brought out, and sat on a wet roof to wait. Rain pattered on the tin. The engine slipped from sight. He looked toward the north. The only thing visible in the sea of blackness was the green gleam of a switchlight, far up the line. There was no white light in sight.

"Wonder where that grouchy old devil is," he muttered. "Ought to be back by this time."

He whistled a strain of "Blue Danube." That made him think of Betty Danforth. He cursed. At the last dance Betty had lifted a tip-tilted nose and refused to dance with him.

He looked at the watch. It was 12.30. No. 8 would soon be leaving Creeping Shadows. He remembered the three pairs of shoes he had seen

beside his train. He looked toward the east. Old Bill's lantern was not showing.

"Why don't that old devil come back?" he asked himself.

He started toward the office, but first extinguished his light. Then he lighted it again, set it on the ground, and, crossing the main track, slipped northward.

Nearing the train, he heard a drunken voice boasting:

"Can't do zhat to me! I'll sho'm. Beat me up an' kick me off'n their damn trains!"

Terry stopped. His pulses quickened. He was not a hero; he was a brakeman. While he hesitated whether to fight or run, he heard another sound. It was like a snake hissing in the grass. It was up by the car of dynamite.

Listening, he heard the *whoo-ee* of a slackening train piston, the clank of releasing shoes, and another hiss.

"The damn yahoos!" he thought. "Lettin' brakes off this train."

Instinct told him "The Rattler" had struck, had disposed of Danforth. How, he did not know. But his brain manufactured pictures. They were not pleasant. They sent sympathy for the old man surging into his heart.

Terry quit thinking about Danforth, remembered there was to be a "big rek," and eased into shadows to wait.

With that methodical precision which follows careful planning, two men were releasing brakes. They talked guardedly.

Terry was puzzled. With his train hanging over the hump, it would not move if they kicked off all the brakes. Still, before the men reached him, the cars between which he stood began moving.

For a second he could not figure what had happened. Then he recalled

that the helper engine had left the slack "bunched." When he had cut off the mine cars, he had easily lifted the pin. The gang had lifted *another* pin, had turned loose a cut of cars with brakes off, and a straight shot back down the grade into the face of No. 8! While he moved with quickening ears, he heard the drunken voice saying gleefully:

"Thash all right, boys! They're hell'n gone now!"

**T**HE cars were gathering speed. Their crawl had changed to a walk. The walk would soon change to a run. He reached for a side ladder, intending to go high and set brakes. He changed his mind. At his first step on a running board they would hear him.

He eased from between. The men were close. Six feet away was the glowing tip of a cigarette. He wondered what they had done with Danforth. The cars moved faster. Terry fingered the club, watched the glowing tip, hurled himself and struck.

The club connected. A hoarse voice groaned. A body fell. Two others leaped back. A hogleg spat. Its boom echoed against the rain-drenched mountain. A shot clipped Terry's sleeve.

Darkness, silence, and cars slipping down the grade. One gone. Another going.

Then there were three shots. The last one was close. Terry fixed the spurt of flame—fixed it and struck. Again his club connected. A second body slumped. A stream of orange stabbed from a gun. A body hurtled toward him, struck him in the middle, took him down beneath it. For the shadow of seconds the world was black. A hand found Terry's throat. Beneath the hand was a pinpoint of cold steel.

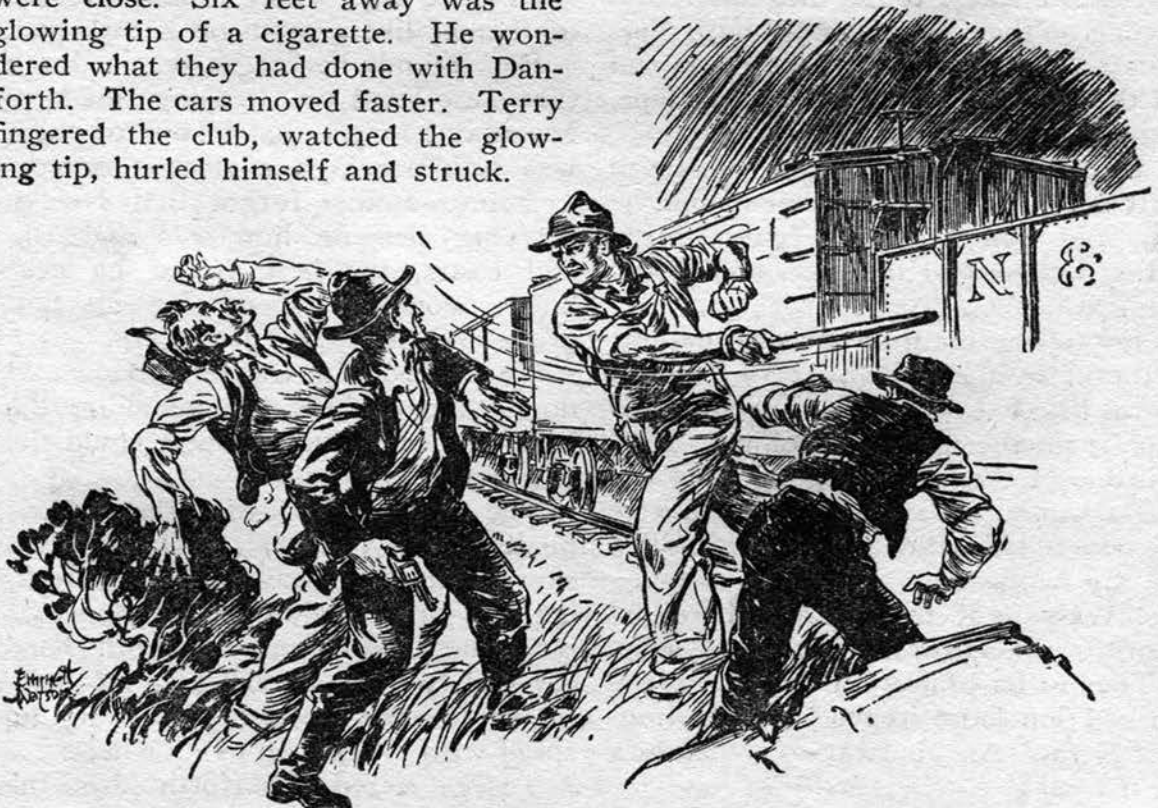

A Hoarse Voice Groaned as Terry Swung His Brake Club

Terry seized the wrist of the knife hand and bent it back. Wrecker and trainman came together. The one was drunk. The other was sober. Terry's big fist found a face, lashed once, twice. Down went the wrecker. Terry was upon him, lifted him, flung him hard into the cinders.

Wheels *clack-clacked* over rusty rails. Panting, trembling until he could scarcely stand, Terry caught the ladder. On it, he remembered his club. Without the club he would be helpless. He rolled off to find it.

Groping in darkness, he fell over a body. But he lit a match, found the club, turned back to where the cars had been. They were not there. From toward the switch came the dull thump of rolling wheels.

Terry struck out after them. He caught a coupling lever. He swung left out of the track, found the ladder, and swung on the coal car loaded with pipe. The brake wheel was at the other end of the car. He stumbled over the pipe, running for the brake.

In the end of the car his foot struck soft flesh. Lighting another match, he saw old Bill Danforth lying in the straw in front of the pipe, bound and gagged.

Forgetting the three cars he had left standing by the switch, Terry dropped down beside Danforth. He jerked the gag from the disfigured mouth. Old Bill began cursing and spitting.

"Damnhoboes! Threwed me in here to take a ride, did they! Wait till I git my hands—"

"We've got to git outa here an' work," interrupted Terry sharply. "They've let brakes off these cars, an' turned 'em loose in the face of Number Eight. An' that car of dynamite's in the cut!"

Terry slashed cords off bound

ankles. Danforth scrambled to his feet. He was in the bottom of the car, ahead of the pipe.

**T**HERE was a sickening jolt. Terry plunged head first into the car wall. Danforth uttered a piercing cry. For a second Terry could not think what had happened. He thought the dynamite had exploded. Then he recalled the cars left standing above the switch. The death wagon had crashed into them. He hoped they had hit the ditch. They hadn't.

Now Bill was yelling.

"My feet!" he cried. "It's got my feet!"

Terry struck another match. What he saw made him turn sick. The collision had shifted the load of pipe. The uneven ends had hurtled forward like an irregular wall of spears, catching Danforth's legs, fixing him to the end of the car like a moth on a cork pad.

For seconds he forgot that a dozen cars were loose on Creeping Shadows Mountain, forgot that in one of them was sufficient high explosive to blow cars into atoms, forgot that No. 8, carrying sleeping hundreds and Big Bill Sears, the best friend he ever knew, would come roaring up that grade and meet them head on.

He worked with Danforth. He could do nothing. Only by unloading the hundreds of lengths of pipe could the conductor be released.

The ominous clack of outlaw wheels finally stirred him. Collision had slowed the death wagon of the wreckers, but three brakes on a dozen cars would not hold them. Already the head car had split the switch and was rolling in to the main line, picking up speed with every turn of its wheels.

Terry seized Danforth by the shoulder.

"Listen!" he commanded, trying to smother the quake in his own voice. "You drop down on this pipe and take it easy. I'm goin' to leave yuh."

"Figgered yuh would," sneered Danforth. "Damnhoboes! You an' them too. They fixed up their death cart. You're goin' to jump off an'—"

"But I ain't goin' to jump!" Terry called back.

"You ain't goin' to—"

The old man hushed. His breathing quickened. Terry hunted for the club. It was under many lengths of pipe. It took time to get it. Threatening *clack-clack* — *clackety-clack* quickened like the throb of a warming motor.

Danforth's breathing was labored. The brakeman could hear it as he fished for the club.

"You might as well jump!" The hoarse voice was almost human. "Yuh can't do nothin'. They'll be runnin' fifty an hour before you get half your brakes set. Get off, an' let 'em go!"

"Yeah!" Terry was tugging at the hickory club. "Jump, an' let 'em slough into Number Eight!"

"I—I ain't never done nothin' to you but bawl yuh out, kid," croaked Danforth.

"You're tellin' me!"

The brakeman came up with the club, floundered by the conductor, climbed from the car, set its brake, and started for the next one.

There was not a ray of light! Nothing but the incessant swish of the drizzle and the menacing grumble of wheels, with their ever shortening *clk-clk—clktly-clk* and the screech and groan of flanges bending main line switch points.

When Terry groped around the end of that car wall, caught the grabiron, and swung out into space, he knew he was rolling the dice of death against

heavy odds. Up he went, like a monkey. The scream of wheels grew louder. Cars lurched and rolled. The brakeman sucked his breath through clenched teeth. He found the brake wheel at the forward end, and iron shoes on iron wheels groaned like dying things.

With foot and club he felt for the roof ahead. No roof was there. Only a black yawning gulf. The car he rode was a high one. The next ahead was a coal car loaded with ore. Down the ladder meant precious seconds, seconds on whose loss might hang victory or defeat in his flight with grade and tonnage. He took the shorter way.

ONE instant he teetered over the wet board. The next he plunged down into the darkness. Below him were rough rocks fresh from mines. His feet struck them, and his knees buckled. Down he went, face first, bruising lips, nose, forehead. He got up and went on.

Another brake he set, and still others. Forty miles an hour—on track carded fifteen! The thought was staggering.

"You can't do it!" whispered a voice. "They're out of control. That car of dynamite! They're going to hit! Unload now! Jump! Join the birds!"

To right and left, wet earth was speeding by, with the gentle rain falling on it. On the wet earth lay life and safety. On the speeding cars lay danger, maybe death.

"'Tain't your fault!" whispered the voice. "Didn't Danforth bring it on himself! Didn't Danforth call you a damnhobo! Let him go! Serves him right!"

But Terry did not jump.

From out of the blackness, a green light gleamed. Green—safety! Terry's

hard eyes glistened. The block signal semaphore a mile from Southport was green. No. 8 was not within the block.

The first car shot by it. The green light flicked yellow; the yellow changed to red.

Other brakes. Other miles. The scream of wheels grew louder. The speed quickened from forty to fifty. And another green signal. At fifty miles an hour the cars reeled out over the Creeping Shadows Trestle. Two hundred feet below black water swirled around concrete pillars, surged and raced on down the gorge.

At forty miles an hour the green switchlight at Older leaped toward him. The block signal was a ball of gold. No. 8 was on the hill!

The cars crashed down the main line between the switches. A frightened operator yelled up from the platform, yelled and dashed inside to call a dispatcher. The lower head block leaped into view. It was gleaming red. By it the outlaw cars reeled recklessly, racing around curves, shooting through limestone cliffs, rumbling over high trestles.

All brakes were now set. They were cutting the speed now. Trembling until he could scarcely stand, Terry was going back over them, twisting each one notch by notch. Fifteen miles an hour, then ten. At every curve, he listened, felt, waited for the crash.

Ten miles an hour, then eight. From down the hill, a soft glow lighted the forest. The blare of an exhaust mingled with the clatter of brake wheels.

The exhaust stopped suddenly, as if a giant hand had choked it. A whistle screamed. At five miles an hour, the outlaw cars staggered into the arms of the oncoming passenger train, rattled, banged, boomed, and stopped dead still. And from them, Terry O'Brien

hurried down to report to a blasphemous engine crew.

In the dripping darkness, willing hands extricated Bill Danforth from the trap of death. He explained profusely and profanely how the damn-hoboes had crowned him, bound him, and put him in here for a ride, and how "my brakeman" had come in the nick of time.

"Best damn brakeman that ever swung a light, that boy is," he bragged. "Why, if it hadn't of been for him—"

A red-faced hoghead nudged a brassbound conductor. A division superintendent grinned knowingly. A confused brakeman flushed like a high school kid with his first date.

**I**N the gathering twilight, he sat with Betty Danforth by a white cot in the company hospital. Old Bill with injured legs encased in splint and bandage picked nervously at the covers.

They talked about the five thousand reward for The Rattler, and how close the call had been that morning, and Bill said again what a jewel "my brakeman" was. Betty laid a hand on Terry's sleeve and turned glistening eyes upon him.

"I knew you were a good brakeman," she whispered.

"Yeah!" Terry flushed.

"Sure. I knew it the first time I laid eyes on you. That's why I wanted you to take this job with—"

Danforth quit picking at the covers, lifted himself to an elbow, glowered at his daughter, then at Terry.

"What—what's that?" he screeched. "You wanted him to take—"

Betty nodded. "Sure! You never had had a good brakeman, Daddy."

"Yuh see, Mr. Danforth," Terry explained, "she didn't know I was a 'damnhobo.'"



# Interference

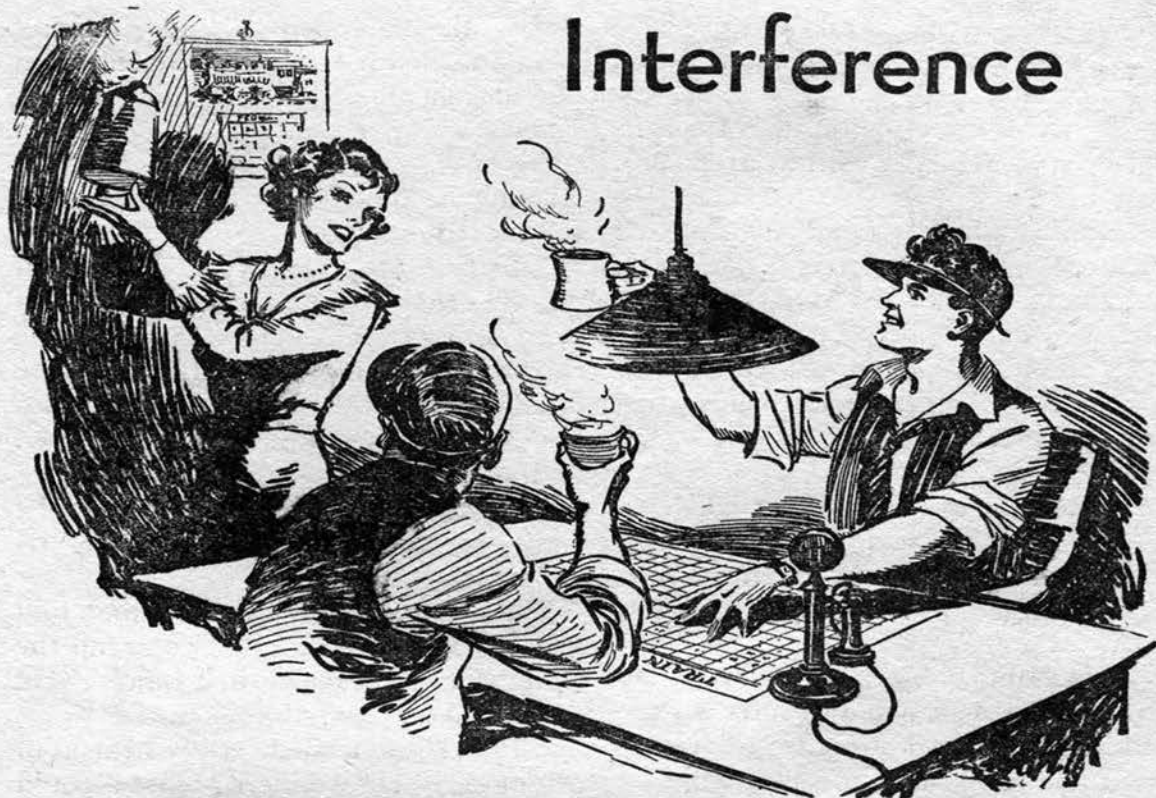

*Dispatcher Billy Gregg Was No Gridiron Hero, but He Tried Football Tactics on the President's Special*

By GRIFF CRAWFORD

Santa Fe Train Dispatcher, Wellington, Kan.; Author of 20 Other Stories in This Magazine

**B**ILLY GREGG walked out into the hall from the dispatcher's office, glad the night's work was done. It seemed to him that railroads always tried themselves in the hours between midnight and eight o'clock in the morning.

"And tonight," he growled, thinking of the hours to come on his next trick, "I'll have the football special on top of everything else!"

That was a sore spot with Billy—football. In his pocket at this very minute was a perfectly good engagement ring which had set him back close to two hundred bucks. It had been re-

turned to him by the fickle Miss Irene Apperson, trainmaster's stenographer. She had suddenly been smitten by one "Pug" Winston, who had made a few touchdowns, and the sport page with his picture.

"When you get *your* picture in the paper, Bill-ee," she had said, "I'll give you another chance."

And Billy Gregg had almost sworn openly. He had checked himself in time. "If I could go down the field with a half dozen yahoos hanging to my hips and get my mug in the Daily Disappointment along with prize bulls, premium dogs and the like I'd be a whizz! Ye-ah?"

"Ye-ah!" Irene had echoed and commenced rattling the typewriter and Billy had stomped out.

"Railroad man—nothing but a railroad man," she was calling after him mockingly.

"Damn railroads—and women!" he muttered. He went straight to Mrs. Mangum's, where he boarded, and started to his room.

"You look like a funeral." He looked up to see Marjorie Phelps grinning at him. She was file clerk in the super's office.

"I feel like one," he admitted.

"Oh, I was just kidding, Billy. You'd better hurry in to breakfast. Mrs. Mangum has little pig sausages and hot cakes."

"Not hungry," he said as he bolted upstairs. A man couldn't have an appetite when he had so many worries—tough job, old Boggs, the super, ill as a bear with a sore foot and always griping, anyway, to say nothing about the two hundred bucks spent for a ring with no finger to put it on.

"Damn football, football specials, Boggs, railroads, women and newspaper pictures!" he repeated explosively as he went to bed.

**B**ILLY had had no misconception of the night's work ahead. His hands were full. The district was sizzling. Flocks of symbol trains heading in both directions; six passenger schedules slated to meet on his stretch of track and three of them reported late; drag freights, belated locals and forthcoming work trains mingled in the mess that was going to make night hideous.

"If they owned any more engines they'd have 'em all out here on this cussed piece of track!" he declared to Danny Holmes, the branch dispatcher

across the table from him. Danny grunted, nodded sympathetically and puffed his pipe. It was old stuff to him.

"Copy seven—" Billy was already wishing he had four tracks instead of the measly one.

"Engine 2197 run extra," he droned out the order making his meeting points with other traffic. He was fixing the returning football special now. He didn't know how the game came out. He didn't want to know. He was tired of the big splurge people were making over Pug Winston. Irene would be right by the big bruiser's side, of course.

Old Danny heard the click that told him another message had come up the chute from the telegraph office. He wandered in slowly to get it.

"Pink!" he bawled. Billy heard out of one ear. He wondered what it could be. These pink messages carried the most important rush wires handled on the railroad.

"Holy jumpin' catfish! You're gettin' the president's special!" Danny yelled excitedly. "Listen. It's from Manson of the B. & A."

**Delivering you Manville Junction  
5.45 A.M. president's special, 6 cars,  
movement your lines Chicago.**

Billy looked at the clock. It was 4.50 now. The corners of his mouth drew down a little. He was wondering how he was going to move that hot shot in and out through that mess of trains without a serious delay.

"O.K., Danny." He reached for the button that would ring a bell in the office at Manville Junction as he said the words. "Get the roundhouse foreman, quick," he instructed the operator who had answered the call promptly. "Tell him I want an Atlantic type hot

and over the table in thirty mintues—he's got one that's warm, it went in on Twenty-seven—call Jim Blake and his fireman and have the call boy inform them they're getting a high-stepper from the B. & A. at five-forty. We're on awful short time. Put the yard-master on the phone."

"Hello, Frank? Call a uniformed train crew—best you've got, to handle the president's special coming from the B. & A. at five-forty. You'll have to send a man down to the wye to pilot their crew through our yards. Step on it, Frank."

Old Danny listened to the fast spoken instructions, nodding his head in approval. Billy might be young in years, but he had a mighty good head. He was doing just what Danny would have done if he had been in charge of the district. Jim Blake was the ace engineer of the D. & E., the ideal man for the job.

Danny fully intended to do all the chores about the office, so Billy Gregg would have nothing to do but handle the situation. But railroads have a habit of doing the unexpected. And just at the time when Danny would have been very useful a bridge on one of the branches took a notion to burn. From that instant the old man had a problem of his own. He was fighting an individual battle which he couldn't drop.

"INDUSTRIOUS men," the words were accompanied by a bit of girlish laughter. Both looked up. Marjorie Phelps stood in the door between the chief's office and the dispatcher's den.

"Hello! I've been getting caught up on my files," she explained.

"Marj, we're snowed under!" Billy groaned. "Danny has a bridge burn-

ing, I've got a heck of a railroad and a hot shot coming up."

"What can I do, Billy?"

"Get long distance. Put in calls for the agents at Pemberton, Barclay and Titusville. Tell 'em to get to their offices as quick as they can. I've got to get my mitts on some of those trains out there in the dark."

"Engine 3536 run extra Manville Junction to Pemberton with right over all trains." He had snapped into his work again. The president would be on his railroad in a few minutes. He heard Marjorie following his instructions. Capable girl. He liked her voice, and that rosebud in her hair.

"Put Jim Blake on the phone," he instructed the operator when the order had been completed. "I want to talk to him when he comes." He kept up the incessant grind of orders and instructions until the engineer came in on the phone.

"Jim, I'm up a tree," Billy explained, "they dumped this high-stepper on me unexpected. I'm giving you a clear shot to Pemberton and I'll try to have another stretch clear by the time you get there. Look out for high-balls from the ops. Keep coming down the main stem if you get 'em. Walk the dog, boy! I'll be handing 'em up as fast as I can to keep you rolling in high. There's a mess down the pike!"

He was working in a sort of an aside from himself, his brain trying to grasp a dozen different moves in a flash. He was concentrating on the order he was sending, but in the back of his head others thrust themselves forward demanding attention. He must keep things safe—traffic moving.

Something moved at his side. He looked up to see Marjorie placing a steaming pot of coffee on the table. She had slipped over to Fred's and got

it. She poured one of the cups full and sat it by his hand and gave the other to old Danny.

"Thanks, Marj. How did you know?"

"Marj is a humdinger!" old Danny barked. "Worth a dozen of these flappers!"

"I'll say," Billy agreed. "Engine 3536 run extra Pemberton to Laird with rights over all trains." He had succeeded in opening another block of track for the president.

"Just like a football game—real football," he was thinking. "Jim Blake lugging the ball and me furnishing the interference." He grinned at the thought. "Jim will get credit for a great run if I can keep him wheeling. Me? I'll get hell from old Boggs."

He saw dimly a form moving quietly about the office. It took tubes from the chute, sorted the wires, poured fresh coffee into the cups, beat a tattoo on the chief's typewriter, fought side by side with him and old Danny, helped the interference to function.

"Hey, Marj," he called, "it's nearly morning. You've been up all night. You beat it for home."

"Today's Sunday. I don't have to work today, simple. It's fun, Billy, helping."

"Some girl!" Billy said to himself.

He had kept Jim Blake roaring down the field without a slow-up. A strict book-of-rule official would have frowned on Blake's coming up the main line on signals from operators here. But the engineer knew what the situation was and he knew Billy Gregg. That's why Jim was the best engineer on the D. & E. He'd always kick in and play ball with a fellow.

In a few minutes the fight would be over. As soon as things cleared around Decatur the battle would be won. From

that point on the track would be as clear as a bell.

AND then a drag freight pulling into the siding derailed a pair of trucks at the head-in switch. The siding and main line were both hopelessly blocked.

"Hand me the blueprint of Decatur, Marj," he said. He studied it a moment when she had placed it before him.

"Listen," he spoke to the waiting operator, "have the drag crew take their engine and clear the cars from the house and stock tracks. Shove them on the passing track ahead of the derailment. Double the eastbound drag over on the main line. Throw the switches onto the house track, over the cross-over connection to the stock track to the main."

Old Danny gulped. It was good headwork—if nothing happened.

"Tell the boys to hurry; they'll have to work fast if we keep the rattler moving."

"The 3536 is pretty heavy for those light rails," Danny suggested.

"If they go in the ditch I'll be canned, Danny, but I'll tell Jim to take it easy and nobody will be hurt." He placed a caution order to the special at Ames and instructed the crew as to the move they might expect at Decatur. He got it to them just in time to keep Blake wheeling. Then he turned his attention to the situation at the derailment. "How they coming?" he inquired.

"They're rasslin' em around," the operator advised.

He kept up a steady stream of information as the moves were being made.

"All clear!" he barked joyously after awhile. "The switches are lined, *and here comes the rattler!*"

"Close." Billy uttered the word wearily as he looked at the girl and Danny. The situation was out of his hands now. He had done all he could do.

A sounder snapped once or twice and was silent. The pendulum of the big standard clock swung slowly.

"Out on the main and gone!" the operator fairly shouted. "Put him by at seven-fifty-nine!"

"O.K., kid. Thanks."

Marjorie Phelps had waited only long enough to know the move had been successful. Then she darted out the door. Danny blinked a couple of times, shook his head and returned to his side of the table. The two relief men came in the door. Billy got up.

"You'll need the big hook out at Decatur," he explained to his successor. "Pair of trucks across the main stem. Hell of a night!"

THEY stood at the station—Billy Gregg and Danny—as the special swung around the curve. The 3536 was a pretty sight in the reflection of the morning sun as she swept along with the private cars behind her. Jim Blake brought her to a stop at the depot as softly as a butterfly lighting on a tulip. Danny looked at his watch.

"What time did they leave Manville Junction?" he asked.

"Six-ten."

"Not bad—a hundred and thirty miles and it's just eight-seventeen."

A gang of newspapermen were hurrying down the platform and rushing to the engine. They wanted Jim Blake's picture. The engineer grinned and stepped down beside the 3536. Then he saw Billy Gregg.

"Wait a minute, boys. I carried the ball, but yonder is the fellow who provided the interference. He's the

dispatcher who made the run possible."

The engineer explained in a few words the difficulties under which his run had been made.

"Nice work, Billy. Never saw better." It was Boggs' voice, and Billy gulped. This was the most unexpected thing of all. It was the first time such a thing had ever occurred in the memory of those who knew the superintendent. Billy had not known the boss was riding the special.

He walked over to where the reporters beckoned him. It was all a sort of daze. Crazy—like the railroad had been. Another train pulled in as the special pulled out. It was the football special that Billy had put on a siding ten miles out to let the president by. One of the first passengers to alight was Pug Winston. He looked glum and took a taxi without paying any attention to the others. A man passing winked at Boggs.

"Pug fumbled and lost the game," he grinned. "The crowd razed him and he's sore."

Irene Apperson came along with other sleepy rooters and barely nodded as she passed. Somehow, Billy reached the conclusion that she and Pug might have quarreled.

MARJORIE PHELPS met him at the door of the boarding house. "You're the tiredest looking man I ever saw, Billy, and no wonder. Now, the little pig sausages are excellent."

"Too tired to eat, Marj."

"Nonsense. Of course you want breakfast. Toast, anyway — and coffee." She hustled him into the dining room.

"Funny," he was thinking as he later went to his room and to bed. "I've always liked blondes best, but I've begun to see that brunettes are more

beautiful and social like." His dreams that day were confused. In them Irene Apperson insisted on reading about football heroes and thrusting Pug Winston's picture in front of him while Marjorie Phelps was toasting delicious slices of bread to a crisp brown.

There came a pounding at his door.

"Get up, Billy." It was Marjorie's voice and she was excited about something. "Hurry downstairs. Hurry, Billy!"

She met him in the hall.

"There! You're famous!" she spread a paper before his eyes. Looking up from the front page was an excellent likeness of Jim Blake and himself standing side by side and under the picture was the word "Teamwork."

The column below carried the story of the run made by Jim Blake with the president's train, and information on how Billy Gregg, dispatcher, had made it possible.

Superintendent Boggs had given the technical points to the reporters without stinting things. It was good advertising for Boggs' division — and the D. & E.

"That's a press association story, Billy," Marjorie reminded him. "It'll be spread all over the state. I'm so glad. I always knew you'd—" She stopped suddenly, blushing furiously.

"Let's talk this over out on the porch swing. It's—not so crowded out there," Billy suggested. An hour later they were still discussing it. And then Mrs. Mangum's voice sounded from the hall.

"Telephone, Mr. Gregg."

Billy came in from the porch and answered.

"Bill—ee?" the voice cooed. "I've just read the paper, honey. I'm so proud of you, honey-boy."

"Yeah?"

"You know that ring was always a bit tight but I think it can be fixed."

"It's already fixed, girlie."

"You're always so thoughtful, dearie."

"Uh-huh. You see, I didn't want to change the ring so I found a finger it just fits—perfectly. G'bye!"

And those were the exact words dispatcher Billy Gregg said to fickle Irene Apperson.

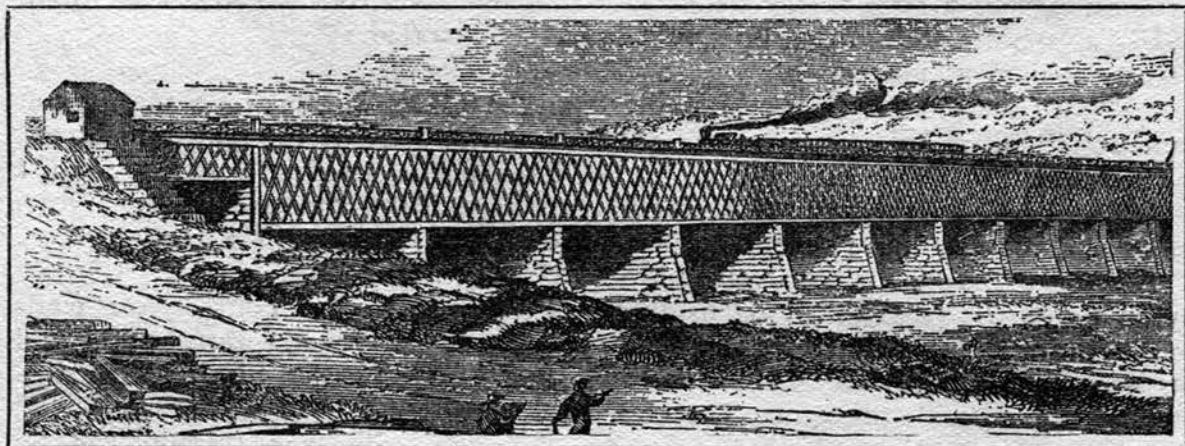

*Old Print from Collection of A. S. Penoyer*

Illinois Central Railroad Viaduct, 2500 Feet Long, at La Salle, Ill., 90 Miles West of Chicago, as it Looked 80 Years Ago. Under This Bridge Passed the Illinois River, a Canal, and the Rock Island Railroad

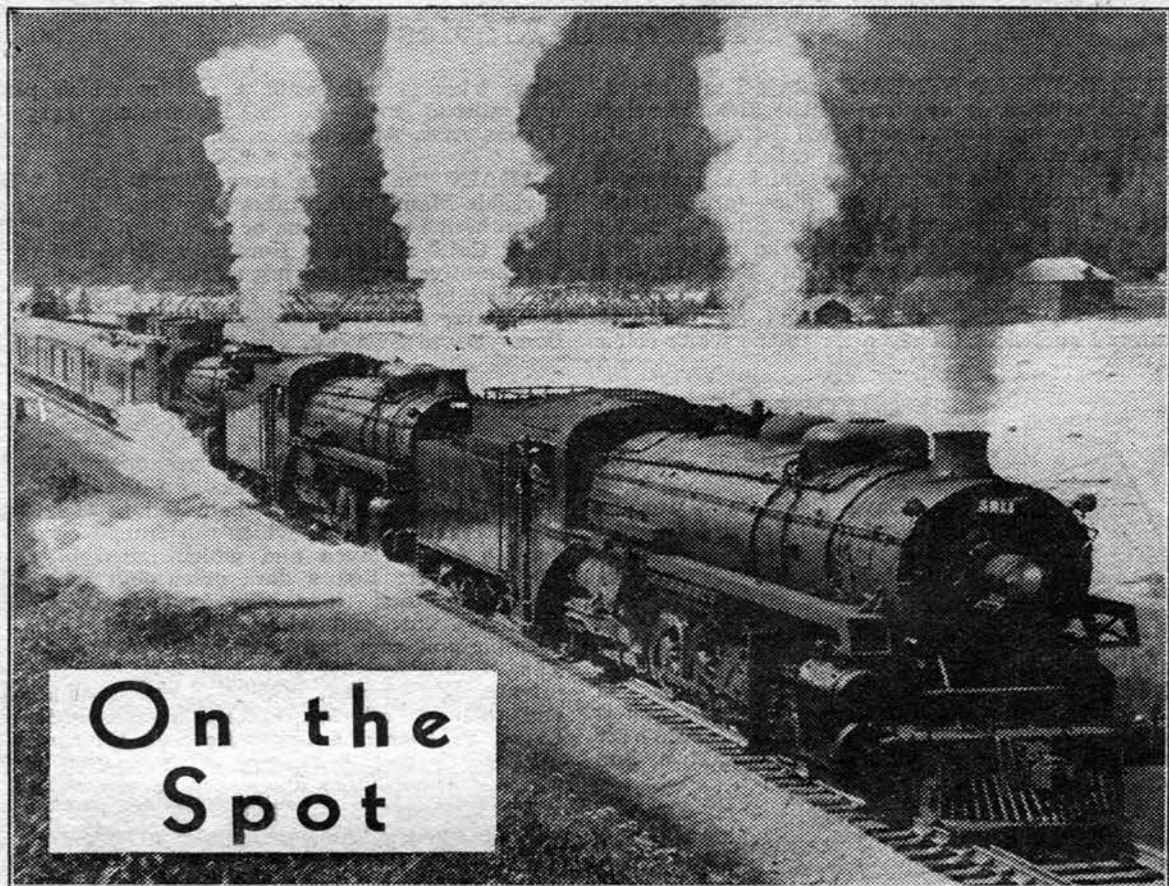

Photo by Nicholas Morant, Hotel St. Regis, Winnipeg, Canada

Railroading in the Canadian Rockies. The Eastbound "Dominion," Crack Transcontinental Passenger Train of the Canadian Pacific, Starting Up the "Hill" at Field, B. C. The Two Mikado Types (Nos. 5811 and 5809) Were Coupled Ahead of the Regular Pacific Type

**T**HIS is a forum for readers all over the world—reminiscences, comments and criticism. Also queries which cannot be answered adequately in the "Lantern."

In each issue we ask you to vote on the most popular stories, features and departments. A "Reader's Choice" coupon is printed on page 143, but those not wishing to clip the magazine may express themselves in a letter or postcard. Returns from the February issue are still incomplete. Votes received so far give this line-up in the order of popularity:

- 1—"Silver Cross," E. S. Dellinger
- 2—True Tales of the Rails
- 3—By the Light of the Lantern
- 4—"Life Begins on the 8.40," E. P. Kid
- 5—"Ballast Scorchers," Bill Hayes
- 6—On the Spot
- 7—"Greatest Engineer," Dave Martin
- 8—"Summertime Snow," James W. Earp
- 9—International Engine Picture Club
- 10—"On the Old C.&C.," J. Considine
- 11—"Circus Went West," E. J. Baker
- 12—Bangor & Aroostook Locomotives

6 R

Although non-fiction occupies slightly less than half the total available space in each issue it usually draws about three-fifths of all the votes.

Every month we get ten times as much interesting material as we can possibly use for the "Spot" department. Due to space limitations, nearly every letter has to be cut before it can be printed; many are crowded out altogether. So when you write to the "Spot" **KEEP IT BRIEF!**

\*\*\*

**DON'T** be disturbed by the "Anvil Chorus" in the Spot dept. Did you ever know a bunch of railroad men who didn't crab about something? You are putting out the best 15c worth on the news-stands.—C. H. BRADY, sec. to Gen. Pass. Agt., C. B. & Q., 547 W. Jackson Blvd., Chicago.

\*\*\*

**SOME** people would kick about the *Encyclopedia Britannica*, they're so hard to please. Your magazine tries to please everyone—steam fans, juice, fiction, non-fiction, model fans—and what a job! The covers are O. K.; don't change them.—F. QUIN, 190 Rocklyn Ave., Lynbrook, N. Y.

## Railroad Movies

"THE SILVER STREAK" movie I saw recently. Remarks made by some of the film characters sound like my story, "Old Hell Bender" (Sept., '34), which also had a train called the "Silver Streak." In this picture the chief characters—as in practically all railroad films—are officials. An old-time engineer fears the Silver Streak's speed, and the hero is a youth who believes that juice is more potent than steam. Said youth is in love with the president's daughter. It's easy to see why such photoplays aren't popular with railroad audiences. They cater to the white-collar

class, whereas rails want a picture which plays up railroad men.—E. S. DELLINGER, 1415 E. Tijeras Ave., Albuquerque, N. M.

\*\*\*

AGAIN the movies have slipped up. "The Invisible Man," which takes place in England, uses a Southern Pacific engine or a model of one. "The Black Cat," also set in Europe, includes a view of a locomotive crosshead just starting. The exhausts are plainly audible, but for each stroke of the locomotive I heard only one exhaust instead of two.—DAVID SWANEY, 220 Olin Ave., Girard, Pa.

## Street Cars, Busses and Trucks



"85 MILES IN 67 MINUTES," by Earle Davis (Nov., '34), was the best article you ever printed. I've developed a new system for reading RAILROAD STORIES; I read only steam-rail yarns and facts, "Light of the Lan-

tern" and "On the Spot," and ignore the busses, street cars and screamline (streamline) junk. If that silly-looking, gas-electric, aluminum worm is the train of tomorrow, I hope the sun doesn't set for at least 50 years.—HENRY WENZEL, R. 6, Box 267, Little Rock, Ark.

\*\*\*

SUBSTANTIAL wage increases were won on the Pacific Electric (largely owned by the S. P.) as the result of a strike called recently by the Brotherhood of Railroad Trainmen and the Brotherhood of Railroad Signalmen. The new scale applies to men with 4 or more years' service. It gives 56½¢ an hour for 2-men cars in local street car service and 60½¢ one-man cars; 63¢ for interurban double track and 65½¢ single track; \$7.14 per day (8 hrs. or 100 miles) for motormen and conductors in electric freight service, \$6.62 for brakemen, \$5.63 for trolley-men; for steam freight service engineers get \$7.16 or \$7.33 and firemen \$5.63 or \$5.75, depending on weight of locomotive.—J. H. GORBY, 4948 Navarro St., Los Angeles.

\*\*\*

TROLLEY lines in New London began with the New London St. Rys., followed by the N. L. Consolidated, the Norwich Line, the New London & E. Lyme and the Groton & Stonington. These lines have all been abandoned, the N. L. & E. L. in 1920, the G. & S. in the late '20's, the New London City lines in 1931, and finally the Norwich-New London Div. of the Conn. Co., on March 17, 1934. The following November the New London and Norwich cars were burned or sold for junk. Now the only trolley in eastern Conn. is the Norwich-Willimantic line.—GORTON WILBUR, 39 12th St., New London, Conn.

\*\*\*

THE Norwich-New London section of the Norwich, New London & Willimantic Line was aban-

doned Mar. 17, 1934, after 35 yrs. operation. Its cars, Nos. 201-210, now used on the Norwich-Willimantic end, formerly belonged to the Short Line Electric Ry. Co., which ran from New London to New Haven and which failed in 1919. The cars were first a dark green, but when the Conn. Co. took them over in 1919 they were painted yellow and white. They were built as multiple-unit cars, but were never used as trains. The N. L.-Norwich line had only 2 miles of private right-of-way, from N. L. to Quaker Hill, and then it followed a state highway.—HARRY LIBBY, 72 Grove St., New London, Conn.

\*\*\*

WHY doesn't G. L. Phillips tell the real reason why so much goods is shipped by truck instead of by rail? Other old rails will agree with me that it always has been—and still is—the practice of railroads to hold a train for more tonnage, regardless of what is already in the train or how rushed it might be. Shippers all over have found this out and consequently use the "truck route" for the best service. If the railroads would get rid of tonnage-mad officials and run their freight trains to give the best of service, they wouldn't have to worry about truck competition.—PAUL CORCORAN (ex-rail, 19 yrs. experience), Box 954, Big Spring, Tex.

\*\*\*

REGARDING G. L. Phillips' articles on trucks and busses: When trolley cars replaced horse cars the companies had to pave all streets over which they ran and *keep them in repair*. Why not compel the trucks and busses to construct their own right-of-way or else charge them a license fee sufficient to pay for highways they use?—E. F. POMPEJI, 103 N. Sumner Ave., Margate Park, Atlantic City, N. J.

\*\*\*

DURING the recent heavy fog which shrouded the Lakes region, a *Chicago Tribune* cartoonist gave the railroads a good boost. His front-page cartoon, "Where the Railroad Has the Laugh on Aviation," showed a locomotive leaving a plane far behind in the fog. For almost 3 days no scheduled departures and arrivals had been made at the Chicago Municipal Airport!—ROY FIDDER, 149 S. 2nd St., Highland Park, Ill.





Oliver Evans, the "Father of American Railroad," Who in 1786 Applied to the Penna. State Legislature for a Patent on a High-Pressure Steam Engine



I'D like to hear from old-timers who worked with me in the Mason City, Iowa, machine shop and roundhouse of C. & N. W. in 1904-5 under Wm. A. Hutchinson, master mechanic, and Frank Anderson, foreman.—WM. E. STORY, 1640 Bingham St., Honolulu, Hawaii.

CAN anyone tell me about an old-time narrow-gage road that ran through Pinecliffe to Central City, Colo.?—R. WINKLESS, 9325 S. Loomis St., Chicago.

YOUR photo of P. R. R. 9999 (Feb. issue) sure was a treat for sore eyes. I fed that old girl plenty of coal and often hit 75 M.P.H. in her cab. Would like to hear from some of the crews on the C. M. St. P. & P. Miles City Div. West.—R. E. McMULLEN, 574 Park Ave., Galion, O.

DOES any old-timer remember the Miller coupler and platform for passenger cars?—WM. B. RAINSFORD, Indian Head, Md.

ENGINE pictured on page 130 (Jan. issue) is old No. 3 of the Rio Grande Ry. (now Port Isabel & Rio Grande Valley), built by Baldwin about 1877; she is now resting beside the P. I. & R. G. V. roundhouse in Brownsville, Texas. Engine No. 1, built by Baldwin in 1871, is in the Chamber of Commerce Park at Brownsville.—MACK TOMME, Raymondville, Texas.

I'D like to hear from Harry McCabe, Joe McHale, Tom Garrity and Joe Gallinger, who used to work with me on the L. V., Buffalo Div.—K. A. KROEGER (loco. fireman), Clyde, N. Y.

## The Information Booth

I WANT the history of 3 dismantled 0-4-0 type engines, Nos. 1, 2, 3, built by the Davenport (Iowa) Loco. Works which numbered them 1046, 1047 and 790. I saw them in Berkeley Corp. yards.—EDWARD DE LANOY, 1148 Amador Ave., Berkeley, Calif.

(EDITOR'S NOTE: We are endeavoring to collect material on Davenport Works to print soon.)

TWO things in Jan. issue caused me to write this. On page 83 mention is made of a train which broke in two and kept merrily on its way. I heard that just a few weeks ago the front portion of a freight train came into terminal and those on the head end didn't know they had broken in two until they got in. It happened just a few miles out of the terminal. The air hose flipped up and the end caught in the coupler or something, bending the hose double and wedging it so tight that it held enough pressure not to set brakes. Car inspectors found it that way.

On page 139 Wilson Rhone asked about a diamond-stacked engine he had seen near Gallup, N. M. This was probably The McGaffey Lumber Co.'s No. 1, which was recently sold to some concern in Mexico and passed through here while being delivered via Santa Fe Lines. She is a Shay engine.—P. A., Albuquerque, N. M.

I'LL be glad to give any dope on C. N. R. power in this locality.—BRUCE SCOTT, Box 61, New Glasgow, Nova Scotia, Canada.

WILL an engineman tell me some of the examination questions asked before becoming a hogger?—JOSEPH CORNILLO, 1900 E. Tremont Ave., Bronx, N. Y.

I'D like to hear from engineers and firemen of the S. P. Austin Div. and of the 2nd District Southern Div. of the Gulf, Colorado & Santa Fe.—WALTER SWIONIK (age 21), Rt. 2, Box 17, Caldwell, Texas.

RAILROAD men, please write.—KENNETH ERICKSON, Heron Lake, Minn.

I'M now studying telegraphy; would like to hear from other Morse students.—RICHARD CONDON, 405 Monroe St., Valparaiso, Ind.

LAST month this department told about a big gray owl flying into a C. & O. cab window; the engineer took the bird home for a pet. Here's another true story to match it: On Jan. 15, '35, a pheasant flew against the cab window of a P. R. R. electric locomotive on express train No. 202 making about 70 M.P.H. near Penn Valley, N. J. It shattered the plate glass and temporarily stunned the engineer, Frank Pearl, of Philadelphia. As Pearl's hand slipped from the controller, the "dead man" safety device automatically cut off the power and stopped the train. Thus a 6-pound



pheasant halted an 853-ton train of ten cars!

A week later another pheasant plunged through the headlight of a limited train on the Milwaukee Road near Horicon, Wis., delaying the train for nearly an hour.

Some time ago we printed a picture of an old-time train stopped by grasshoppers. Now read this one. Last Sept. 15 (according to information from W. D. Sherman of Rusk, Texas) millions of "army" worms streaming across the tracks stalled a Ft. Worth & Denver City (Burlington) freight train puffing up Carey Hill, Estelline, Texas. The drive wheels of the engine began to slip and the train came to an abrupt halt. Trainmen found the tracks covered with worms that had crawled out of weeds and grass when hail beat down their shelter. Finally the train was split into sections and it was possible to move the cars past the slippery stretch.—EDITOR.

\*\*\*

ENGINE grease is made by the S. P. as follows: They take chippings from old journal packing, excess and old grease from engines, and all other old grease they can find, compress it into sticks about 10 inches long and 1½ inches in diameter, slap a little graphite on the outside and use it over again. I asked a greaser at Eugene depot whether or not it was good stuff, and he replied: "If it was, the S. P. wouldn't have it."—J. M., Eugene, Ore.

IN January a narrow-gage double-heading D. & R. G. W. passenger train was marooned for several days in snowdrifts, some 20 ft. deep. The scene was Cumbres, Colo., 10,000 ft. above sea level. In the train were the crew and 14 passengers, who were enjoying steam heat supplied by the locomotives. A huge supply of food, stored by the railroad for winter emergencies, was available a few hundred yards from the stalled train at Cumbres station. A path was made to the station, and the passengers, including 3 children, were said to have "lived like kings."

\*\*\*

Answering a query: "Murder in the Private Car" was filmed on the S. P. Shasta Route near Dunsmuir, Calif.—ALBERT PHELPS, Auburn, Calif.

\*\*\*



OUR April front cover recalls a recent incident at Morris, Ill. John Prombo saw a cow placidly chewing her cud on the Rock Island Railroad in front of an oncoming train. Prombo raced down the track, coaxed and pushed the animal, but she refused to budge. Just as the train was upon them the cow loped to safety. Prombo was killed.—EDITOR.

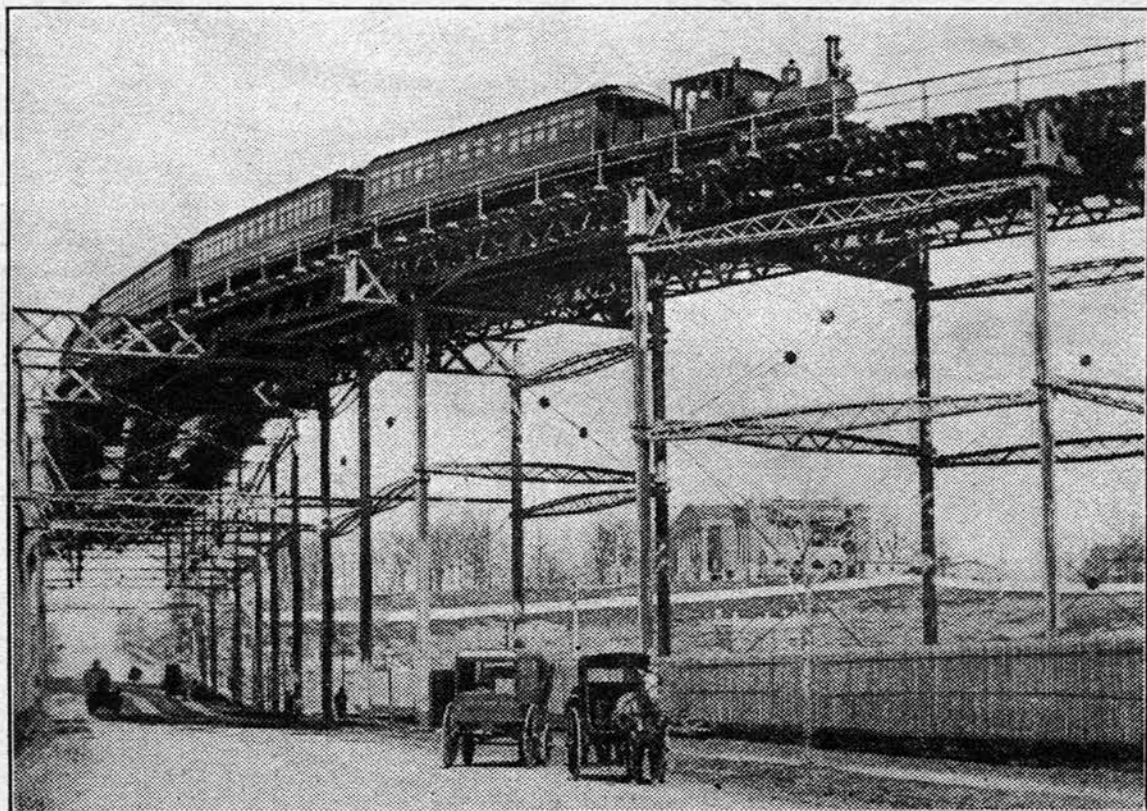

Back in the Horse-and-Buggy Days, Forney Type Steam Engines Pulled Trains on the Sixth Ave. Elevated, New York City. Photo Shows "Death Curve" at 110th St. This Old Structure Will Soon Be Torn Down and Replaced by a Subway

## Jobs for the Wrecking Crew



I WANT details on 2 wrecks about 30 yrs. ago. One was at Litchfield, Ill., on the Wabash during the St. Louis World's Fair, with one of the 600 class locomotives, the high-wheeled Atlantics still in service. The other was on the I. C.; 3

engines were involved, one being the 1108, a new Pacific which nearly went to the junk pile. My father helped rebuild those I. C. engines after the wreck.—ARTHUR EGGLESTON, 7123 Joy Rd., Detroit, Mich.

\*\*\*

IN your Oct., '34, issue (p. 134) is an old print of an N. & W. passenger coach balanced on the edge of a bridge. Once I saw a coach in practically the same position. Your print shows both trucks hanging to the body of the car. I was told the car bodies were mounted on the truck by a king bolt, and if suspended with the weight of the trucks hanging like your picture shows, the trucks would detach themselves. I know there were 4 chains on each truck, but even assuming they were strong enough to hold the truck, the whole picture looks unnatural. How come?—E. C. HUFFSMITH, 243 Atlantic, Long Beach, Calif.

(EDITOR'S NOTE: We don't know anything about this, except that we believe the old print was an exact copy of a photo.)

G. H. B. (Dec., '34) said Reynolds was engineer on Soo train No. 2, wrecked near Chippewa Falls, Wis. This is incorrect; the engineer was Caldwell.—JOHN REEVE (furloughed Soo fireman), 5813 23rd Ave., Kenosha, Wis.

\*\*\*

DELLINGER'S story, "Crossings" (Jan., '35), doesn't ring true in one respect. He has the engine badly wrecked at 50 M.P.H. after hitting some sheep. My father, a Soo Line engineer, while running at 60 M.P.H., hit a large flock of them, killing 29, and kept right on going.—J. C., Minneapolis, Minn.

(EDITOR'S NOTE: Any experienced engineer will tell you it is quite possible for sheep to wreck a train running at 50 M.P.H.)

\*\*\*

WHO knows about a Rock Island freight train wreck in Arkansas in the summer of 1914 or 1915? I was a small boy then, but I remember being on a passenger train right behind the wrecked freight. Some one said the crew had been killed.—WILLIE ALLISON, Maxwell, Ala.

\*\*\*

WHO has details on a P. R. R. freight wreck in 1916 at Holtwood, Pa.? I have photos of it but no information.—WM. GARDNER, 811 F St., Sparrows Point, Md.

## Along the Streak o' Rust



SOME time ago the Adirondack Ski Club chartered a "snow train" on the D. & H. for an excursion to the famous Gore Mt. ski run at North Creek. The D. & H. asked for a guarantee of 175 passengers at \$1.50 each for the round trip between Troy or Schenectady and North Creek; or \$1 between Saratoga and North Creek.

When the train pulled into my station there were 373 passengers aboard. She was a double-header, both 4-4-0's, the head engine a "Mother Hubbard" and the second an Atlantic type rebuilt from a "Mother Hubbard." There were 10 coaches, 2 baggage cars for skis and sleds, and a dining car. The trip was so popular that the D. & H. ran more "snow trains."—R. DAVIDSON, 121 Caroline St., Saratoga, N. Y.

\*\*\*

I AM proud of my uncle, E. S. Dellinger. Like him, I was born in the Missouri Ozarks. I started firing for the Mo. P. in 1915; from there I went to the Burlington, and then to the Frisco, where I have been working for 17 years. Was promoted to the right-hand side in 1926. During the World War I ran and fired engines in France.

Fourteen years ago in the yard at Rosedale, Kan., we were ready to go with about 80 freight



cars. It was almost time for an M-K-T passenger train to come along, so our engine foreman called up the dispatcher and got some time on him; then we headed out the crossover onto the main line. We had our engine and 3 or 4 cars on the main when the air going back stopped us. After standing there 10 or 15 minutes we got the air again. The Katy passenger was coming, so we tried to back into the yard, but it was uphill and we had to go ahead. We got about 15 cars on the main when the Katy engine came. Her fireman was putting in a fire and they sure were pounding that jack. They ran into us, turned over 3 cars and put a car almost into the Katy roundhouse. No one was hurt. It has always been a mystery to me why that engineer plowed into us, as we were in an electric block system. He must have run a red board.—C. E. DELLINGER, 3921 Cambridge, Kansas City, Kan.

\*\*\*

RAILROAD STORIES is so popular among the "rails" that I find it easier (in spare time) to sell subscriptions than to write stories.—BOZO TEXINO (Mo. P. hoghead, author of "Rights Over Everything"), Box 564, Laredo, Texas.

\*\*\*

I USED to be an aviation bug until I chanced upon a copy of RAILROAD STORIES, which beats all aviation magazines by 10,000 miles. The Engine Picture Kid had better mend his ways or he'll lose Goldenrod. Tell Johnny Thompson I get a big kick out of those stories.—LESLIE MARTIN, R. D. 1, Box 433, Richfield Springs, N. Y.

## Engine Picture Enthusiasts

A CHICAGO RAILROAD CLUB has been organized for young men. We took our first trip to the 27th St. roundhouse of the I. C. and were escorted by General Foreman Gebhard, who said engine picture fans could snap all the photos they wanted during the tour. We plan to take many more such trips. New members welcomed. For details write ALLEN SHAPIN, 3546 Lawrence Ave., Chicago.

\*\*\*

OKLAHOMA fans are organizing a local division of the International Engine Picture Club. For details write C. SID TUCKER, JR., 224 W. 14th St., Oklahoma City, Okla.

\*\*\*

I WAS taking engine pictures in the N. Y. C. yards at St. Louis when a man asked me what I was doing. I showed him my International Engine Picture Club pin, and he said: "I have met many of you club members. Go right ahead!" He was Trainmaster Snyder of Union Station. The pin has helped me out in many tight places. I wouldn't be without it.—SID TUCKER, JR., 224 N.W. 14th St., Oklahoma City.

AN I. E. P. C. button was among the treasured possessions of my 12-year-old son Bill. He lost it, and I suggested he write for another, but Bill said it was against the rules. Is this true?—C. L. SCHWARZKOPF, 333 E Street, Eureka, Calif.

(EDITOR'S NOTE: Any I. E. P. C. member who loses his button can get another by sending a self-addressed stamped envelope with a "Reader's Choice" coupon completely filled out. If you don't want to clip your magazine, write the information on a separate sheet of paper.)

\*\*\*

SEND me an International Engine Picture Club pin, as some officials are picky about who takes pictures in their roundhouses and yards. Santa Fe men here are nice to picture fans.—DAVID BLAINE, 2025 Fletcher Ave., S. Pasadena, Calif.

\*\*\*

AN easy way of calculating the speed of a train is to clock the number of seconds taken to cover a  $\frac{1}{4}$  of a mile, and then divide that by 900. Thus  $\frac{1}{4}$  mile in 40 seconds, divided by 900 gives  $22\frac{1}{4}$ , the speed of the train in m. p. h.—WM. B. SCHALLEK, 7 W. 81st St., N. Y. City.

## Fiction of the Roaring Road



THE ENGINE PICTURE KID scooped the world with his latest yarn, "The Streamline Comes to Town" (March issue). The day after that issue came off the press, with a double-page fiction illustration of

an iron horse hauling a streamline train, such an incident actually happened on the C. B. & Q. near Hamburg, Iowa. Motors failed, so a steam locomotive pulled the much-advertised "Zephyr" into Omaha and on to Lincoln, Neb. We hope someone got a good photo of this.

The author of these stories is Johnny Thompson, an ex-tallowpot living on a farm at Gilsom, N. H. Johnny would like to hear from some of the readers. Up there in the granite hills, he often gets lonesome for the railroad. Especially a few weeks ago, when his wife Olive was in a hospital and the Kid missed her so much that he just couldn't write a funny story for the April issue. But Olive is better now, so he packed a carload of laughs into a truck-competition yarn, "Super Service," coming next month.—EDITOR.

\*\*\*

REGARDING my story, "Christmas Test" (Jan., '35), and "The Ballast Scorcher," by Hayes (Feb., '35), both dealing with tests by trainmasters, rails tell me that "some brass hats are still at it." Here's one sample: "The spotters just pulled a fast one on a night freight engineer. While running on straight track they sprang a block on him and then discharged the engineer because he ran by it the length of the engine and 3 cars. Had he stopped in front of the signal, he told me, he surely would have bunged a couple cars and tied up the westbound track."—FRANK HILKER, Rt. 2, Box 56-A, Decatur, Ill.

I WAS a regular reader of the old RAILROAD MAN's from 1910-19, but I didn't know of RAILROAD STORIES until last November. It sure is a worthy successor. I enjoyed Tyler's "Railroad Drummer" (Dec., '34) because I am telegrapher with 42 years' experience and found no flaws in his descriptions.—WM. SPAFFORD, 4306 N. Laramie Ave., Chicago.

\*\*\*

"RAILROAD DRUMMER," by Chas. Tyler (Dec. issue), was excellent. Give us more stories about the lesser known rails such as mail clerks, signal maintainers, freight handlers, Pullman employees, towermen, etc.—S. P. DAVIDSON, 902 Swann St., Parkersburg, W. Va.

\*\*\*

I APPRECIATE Dellinger's story, "The Silver Cross," because it depicts a character rarely mentioned in fiction—the "news butcher."—E. F. J., Atlantic City, N. J.

\*\*\*

DELLINGER is your best author, but tell him to cut out the murders. In my 17 years as fireman I have come across but one murder.—H. C. JOHNSON, 2622 Margaret Ave., Maplewood, Mo.

\*\*\*

AFTER reading Dellinger's "Silver Cross" and Jim Holden's "It Happened in Real Life" (both in Feb. issue) I recall another case where a conductor was killed on his train. In Oct., 1892, I went to work on the El Paso Div. of the old G. H. & S. A. Ry., now known as T. & N. O., the Atlantic system of the S. P. The boys there told me that few months previous a conductor had been stabbed by a drunken passenger who refused to pay his fare. It occurred at Valentine, the first freight division point east of El Paso. P. B. McNeal, retired chief dispatcher, or W. M. Stock-

well, former conductor, both of whom were on the road at that time, should be able to supply details. Mr. McNeal lives at 923 N. Oregon St., El Paso, Texas, and Mr. Stockwell at Scottish Rite Temple, El Paso.—GEO. C. HASLITINE, Box 518, Ft. Stockton, Texas.

\* \* \*

"NO-BILL," by Earle Davis (Jan. issue), is true to life. When the children came I was forced to drop my union card. Soon the listings of

"no-bill" appeared with my name. Being hot-headed, I berated the union, loudly but not maliciously. Two months later I missed a 5-day recall notice which was supposed to have been delivered to me by phone. Then I was suspended, and now I have been discharged, although no notice was given me. As for fighting the case—well, I'm just a no-bill.—CHARLES MURDTEK (formerly on N. Y. S. & W. R. R.), 172 Academy St., Jersey City, N. J.

## English Fans Heard From



EVERY railway tale I've read in our English railway journals was just unadulterated tripe, written by someone who once bought a railway ticket and thinks he has a railway background. So I was skeptical when I bought my first copy of RAIL-

ROAD STORIES, but I soon found you had the real stuff. I was surprised to read of an American locomotive boiler explosion. Such a thing is almost unheard-of in England. There has been just one case since the war; an L. M. S. 0-8-0 type blew up at Buxton, due to the safety valves being ground too fine; when heated, they bit into the seatings and refused to budge.

A fine performance was made on the Great Western Ry. here with a 2-6-0 type having 68 in. drivers and weighing about 60 tons. She covered 110 miles, London to Birmingham, in 2 hours, with a train of 14 bogie coaches averaging 37 tons each. Maximum speed was 76 M.P.H. It took a superb engine and first-class men to set this record. In the future, whatever may take the place of steam will never gain as much place in our affection as our old locos. Keep printing stories about them.—C. BROOKS, 29 Russell Road, Hendon, London, N.W.9, England.

EARLE DAVIS (Nov. issue) described a record run by the Milwaukee on July 20, 1934, between Chicago and Milwaukee, at an average of 90.06 M.P.H. for the 68.9-mile stretch between the city limits. The highest point touched was 103 M.P.H.

On Nov. 30, 1934, the famous "Flying Scotsman," hauling 6 cars, touched 97½ miles an hour on a record-breaking non-stop run between Leeds and London. The train was in charge of V. M. B. Ward, supt. of the Western section, L. N. E. R. It covered the 186 miles in 152 minutes, average 73.8 miles an hour; 155 miles was run at an average of 80 M.P.H. The round trip from London to Leeds, 372 miles, is the fastest ever made in the history of British railways. London to Leeds—186 miles in 152 minutes. Leeds to London—186 miles in 157 minutes. A dynamometer car was attached to the train on the outbound trip, with instruments for measuring speed and tractive effort. Between Corby and Peterborough, 15 miles, an average speed of 90½ M.P.H. was maintained. This equals the Milwaukee's record, although for a shorter distance. However, the English trains were light, 3 cars up and 5 down. By the time this letter is printed, even these records may be broken. On both sides of the Atlantic, the railroads are speeding up.—W. J. P.



## Railroad Slang

YOU print too many stories, not enough railroad lore. Your covers are gaudy and cheap. The "Famous Engineers" series and the old prints showing wrecks, etc., are just plain junk. Eliminate slang; it is disgusting. Possibly railroad men spoke that way 50 years ago, but today they have sense enough to call an engine an "engine."—HARRY L. WYNN (author of "Build an Engine Model for 40c."), 40 6th St., Lewisburg, Pa.

\* \* \*

REAL railroad men are not the swearing, slang-throwing kind that most of your authors portray. Instead, they're usually men of character with the usual human weakness, such as those depicted by Frank L. Packard. For that reason Packard is my favorite author.—GARLAND PETERSON, 510 W. 37th St., Norfolk, Va.

\* \* \*

GIVE us more motive power rosters, European railroading, and old wreck pictures, the like of which will be entirely missing in a few years.

Here are a few more railroad slang terms to add to the long vocabulary printed in your Oct., '32, issue:

*Muzzle loader*, a hand-fired engine; *Wabash*, to corner a car; *mud-sucker*, a non-lifting injector; *sunbuckle*, a rail bent by the sun's heat; *bullnose*, front drawbar on engine; *snakehead*, a rail coming through a car floor (this was not uncommon 60 years ago); *Big Swede*, stoker or coal-pusher; *breast-beam*, front beam on engine or back beam on tender; *Little Nemo*, trailer or tender booster; *drum*, hard conductor; *bottle*, Elesco water heater; *boiler-wash*, a high-water man; *rolled*, be caught in close clearance; *Jim Crow*, a rail-bender; *maul*, to work an engine in corner with full throttle; *high-grass*, Central New England R. R.; *gunshoe*, a spotter; *doghouse*, 4-wheel caboose; *ram*, injector; *the York*, the N. Y., N. H. & H. R. R.; *goose her*, to make emergency stop; *blue-liner*, employee stealing from cars.—F. J. BROOKS, Gt. Pasture Rd., Danbury, Conn.

## In the Maple Leaf Dominion



**SPANISH RIVER WRECK.** Answering a query from L. J. Anderson: This was one of the worst wrecks in Canadian railroading; 65 killed, many injured. It occurred Jan. 20, 1910, at Nairn Centre, Ont., where the Soo branch of the C. P. R. crosses the Spanish River, 31½ miles west of Sudbury. Train No. 7, west-

bound, Montreal to Sault Ste. Marie, was in charge of Engineer Harry Trelford and Conductor Tom Reynolds. She was on time, running at normal speed, which in those days was about 40 M.P.H. Approaching Spanish River bridge, the train suddenly broke in two behind the baggage car. The second-class passenger coach plunged down to the river's edge. The first class coach shot by into the cold river, while the diner slid down on its side, with the forward end submerged, and the sleeper just behind. The engine, mail and express car and baggage car went on over the bridge and stopped just past the west abutment.

Only one person in the first-class coach was saved—a man who lay for 5 hours clinging to the top of a lamp with about 8 inches of air space between the water and the car roof. If this incident were mentioned in a fiction story some of you critics wouldn't believe it.

Conductor Reynolds, who was in the diner, was the hero of the wreck. After being thrown to the forward end of the car, under water, Reynolds broke the windows and crawled out, coming up

through the water outside the car. Then he smashed more windows, crawled back in, and dived down to rescue others. The temperature was mild but at night sank to zero, hampering the divers in their work. As one of the men who was hurried to the scene on the rescue train, I helped to list the effects of the dead. In one case I carefully thawed out a roll of bills, \$147, frozen hard as a rock. Do not print my name.—C. P. R. OFFICIAL, Toronto, Canada.

\* \* \*



A QUESTION is frequently asked: "Why can't steam locomotives attain the high speed of Diesel electrics?" The answer is, back pressure on the pistons. Getting expended steam out of the cylinders is an even greater problem than getting live steam into them.

The speed at which a modern locomotive will run on paper and in actual practice will always provide endless argument for the speed enthusiasts. The fact remains that a critical point is reached in the operation of the steam engine when it is impossible to make the steam travel through the full cycle of its operations from the boiler through the valves into and out of the cylinders, through the exhaust nozzle and out of the stack, at a greater rate than a certain maximum speed. Experiments with double exhaust tips, wider smokestacks and improved front ends have gradually raised this critical point, and speeds of 80 M.P.H. are now commonplace.

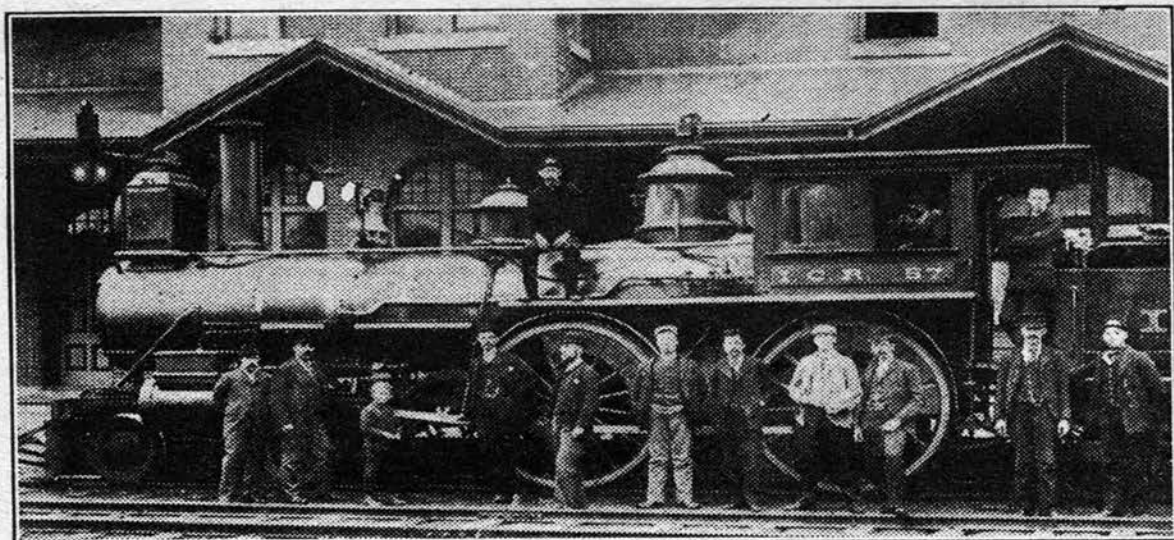

Eight-Wheeler No. 57 of the Inter-Colonial Ry. (Now Canadian National) at New Glasgow, N. S., in 1895. Standing On and Around Her Are the Engine and Train Crews and Dispatcher's Office Force. G. J. Ryan, 2101 Beekman Place, Brooklyn, N. Y., Who Sent Us This Photo, Was Chief Dispatcher. He Is Standing Fourth from the Left, and His Son Is to His Right. The 57 Had 16 x 22-Inch Cylinders, 61-inch Drivers, Was Built by Manchester in 1872 and Scrapped Before 1910

Another important point frequently overlooked is the problem of *lubrication*. Pistons and valve mechanism are moving with extreme rapidity as the speed of a steam locomotive passes the 80 mark, and any failure of the oil supply would soon result in disaster. Locomotive engineers have had unpleasant experiences along these lines. However, the problem of lubrication is gradually being overcome, and the steam locomotive is a long way from being backed out of the picture by the Diesel engine.—WM. J. PARRY (engineer, Canadian National Rys), 906 Chatham St., E., Windsor, Ont.

\* \* \*

ABOUT 30 years ago when I was firing on N. Y. Central they had several inspection engines such as the one pictured in your Feb. issue. As nearly as I can remember, they were the "Niagara," "Ontario," "Mohawk," "Catskill" and "Hudson." They had 10 or 12 in. cylinders, 130 lbs. steam pressure and were the only engines equipped with electric headlights. In those days it was thought that engine crews could not see block signal colors plainly because electric headlights were so bright. Officials would ride in front end of the cab just over the running board and boiler.—W. A. FUNNELL, Moose Jaw, Sask., Canada.

CANADA has probably the oldest living section foreman in North America, according to the *Canadian National Railways Magazine*. He is Andrew Ormiston, of Hopewell, Nova Scotia, now in his 92nd year. Mr. Ormiston worked on the Nova Scotia Ry., now part of the Inter-Colonial, and helped to build the part between Halifax and Truro. He has a son employed as ticket agent and operator at Bridgewater. Another son is driving a switching engine in Stellarton yard. The veteran section foreman, at the time of his retirement from active service in 1913, was employed as general foreman at Truro, N. S.; he joined the railway service in July, 1867. At the age of 13 he drove a horse and cart on construction work on the Nova Scotia Ry.

\* \* \*

I WANT details on wreck near Georgetown, Ont., about 1891. I barely remember my parents talking about it. They had intended to take that train but luckily missed it.—M. M. TURNBELL, Kinsella, Alta., Canada.

## Abandoned Pikes

### NICKEL PLATE ROAD

A SINGLE-TRACKED, rusty, weed-covered abandoned road extends southward from the Nickel Plate main line and parallel to the Cleveland-Euclid, O., boundary, upward through a narrow gorge to the old Bluestone quarries. This road is a mystery to most folks.

Shortly after the Civil War the first extensive bluestone deposit was uncovered in that locality. Almost overnight the village of Bluestone came into being. It had a post office, church, saloons and a store. When winter set in and mule teams could no longer be used down the treacherous shale bank, the Euclid R. R. Co. was formed. For years it did a rushing business, hauling out the stone and bringing in supplies. Then Bluestone disappeared almost overnight. All you can find now are a few piles of brick and half rotted timbers. The road is abandoned.—BERNARD DAW, 155 E. 209th St., Euclid, O.

\* \* \*

ALL that remains of the old Port Chester & Ridgefield R. R. are a few piles of rotted ties along the right-of-way. This road was graded but never built. The roadbed runs through my property.—E. T. MEAD, North Street, Greenwich, Conn.

\* \* \*

I WAS sorry to hear of the abandonment of the San Joaquin & Eastern mentioned in Feb. issue (p. 135). From 1925 to 1927 I was employed by the S. Calif. Edison Co. at Big Creek, northern terminus of the S. J. & E. Often I rode over this little pike, which had 12 locos of the Gerard type (Climax), 26 pass. coaches and 20 frt. and flat cars, and extended 68 miles through the beautiful high Sierras range, serving 3 lumber companies.

Curves were so sharp that at almost every one the air or train line would come apart, stopping the train on a mountain side. As we looked down the deep canyon it seemed miles to the San Joaquin River. After a stop, the crew would drop down the mountain, couple up the train and start the climb once more. If we were lucky we made it, but usually we had to repeat this process many times before we finally reached Big Creek. The longest train I ever saw used on the upgrade had 3 frt. cars and crummy. Passenger trains usually had only 2 coaches and took 6 hours to climb the mountain. Last August, on our vacation, wife and I decided to revisit Big Creek. It was a shock to find the San Joaquin nothing but a skeleton.—Z. B. KNAPP, 921 Leonard St., Los Angeles.

\* \* \*

I NOTICED Roy Peterson's description of the last steam-drawn pass. train on the C. & N. W. Chicago-Freeport branch (Feb., '35). Why don't the people there follow the plan tried in Menominee, Mich.? The C. & N. W. ran a gas buggy on the Menominee-Green Bay Div. for 2 weeks, and then were forced to return the old steam engine because of the strong public opinion against the gas engines in that territory.—C. E. MUNSON, Republic, Mich.

\* \* \*

A SECTION of old abandoned track with rusty steel rails can be seen in the Cascade Mts. east of Salem, Ore., 40 miles from the nearest railway connection. Natives say it is part of a railroad from Newport, Ore., to Boise, Idaho, started in 1877. Construction was completed only from Newport to Corvallis. The road was bonded for \$10,000,000 and later sold to the Hammond Lumber Co. for \$100,000.—J. E. SCHWARTZ, 2234 Jefferson Ave., Ogden, Utah.



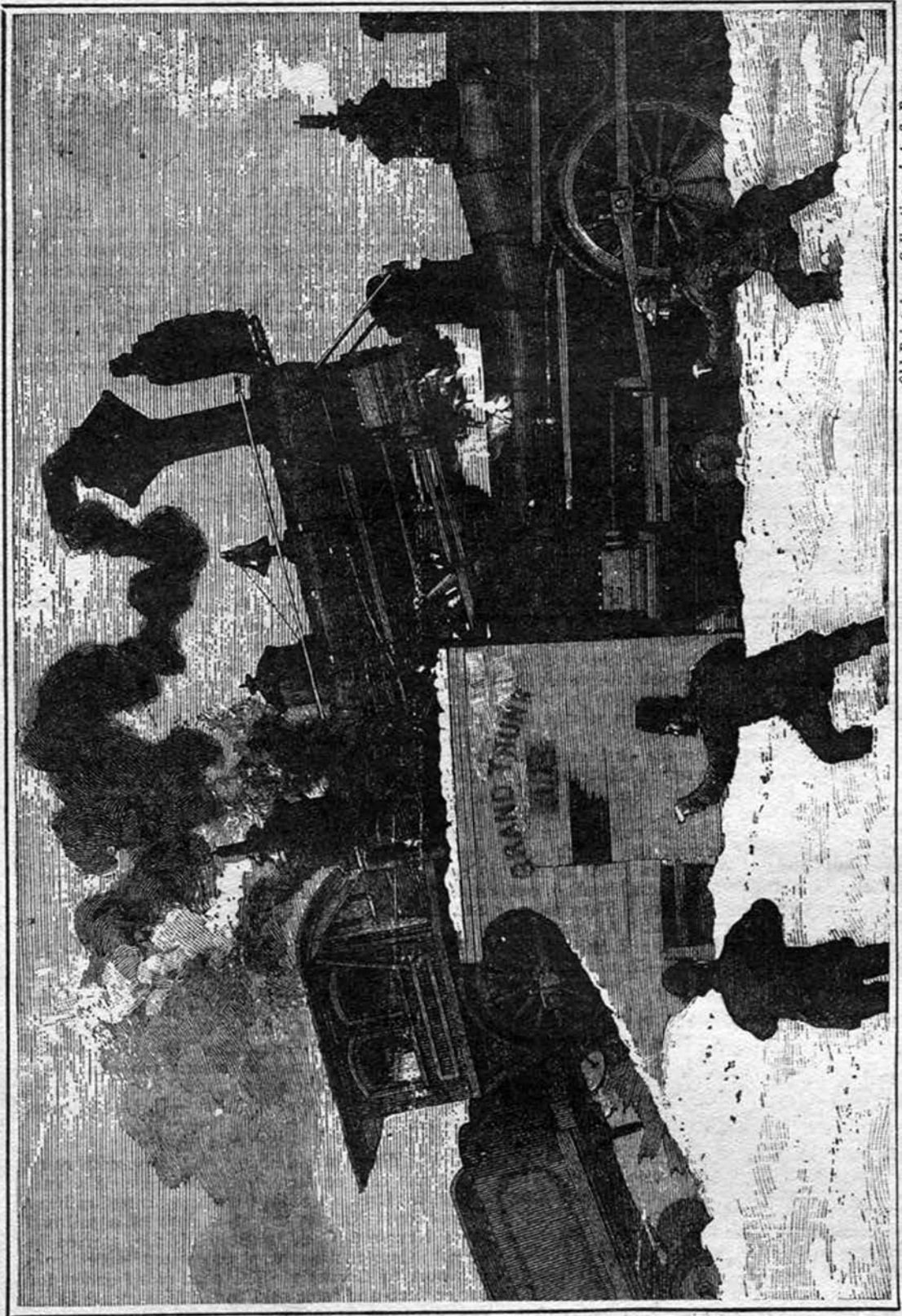

*Old Print from Collection of A. S. Penoyer*  
"Cornfield Meet" between Two Wood-Burners at Lindsay, Ont., Canada. The Picture Seems to Have Been Drawn from a Photo Made Immediately after the Collision, as Smoke is Still Pouring from the Stack. It is Broad Daylight and No Snow is Falling; the Engineers Must Have Been Able to See Ahead. Evidently the Wedge Plow Protected the Locomotives from Serious Damage. Will Some Old-Timer Supply Details?



# Build a Model Wedge Plow

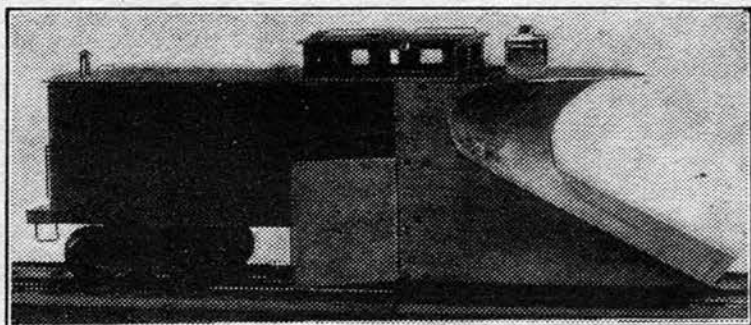

Model by G. A. Vaughan, 701 127th St., College Point, N. Y.

By LEONARD COOPER

**E**VERY outdoor model railroad should have a snow plow. Mine was made at very low cost. When put in front of my Mallet compound (photo in Feb., '35, issue) this  $\frac{3}{4}$  inch scale wedge plow does real business in 6 or 8 inches of snow. Such a model can be created as follows:

First make wheels for the trucks. Get a piece of old 2 inch shafting, place it in a lathe, and hacksaw off 8 disks  $\frac{7}{16}$  inch thick. I said "hacksaw" because, with the lathe running, it saves time and material. Drill a  $\frac{5}{16}$  inch hole in the center of each disk, and press onto axles that have been previously made up from  $\frac{3}{8}$  inch steel rod and turned down to  $\frac{5}{16}$  inch where the wheel goes on. If the fit is too tight, bending of the axle will result. To overcome this a loose fit can be made. Tinning the joints and sweating will produce a nice job. The axle should project through the wheel about 1 inch for the purpose making the journal later.

Next place a pair of these blank wheels in the lathe. Holding one wheel in the chuck, use the steady-rest just back of the other wheel. Anyone familiar with car wheels can now grind a tool to face off the blank wheel tread and the outer side. Then turn the journals to size. Reverse and repeat. After all wheels have been finished in this way, remove the steady-rest. Hold the wheels in the chuck by the tread next to the flange, and finish the back side in like manner. Of course wheels can be bought from a model supply house, which

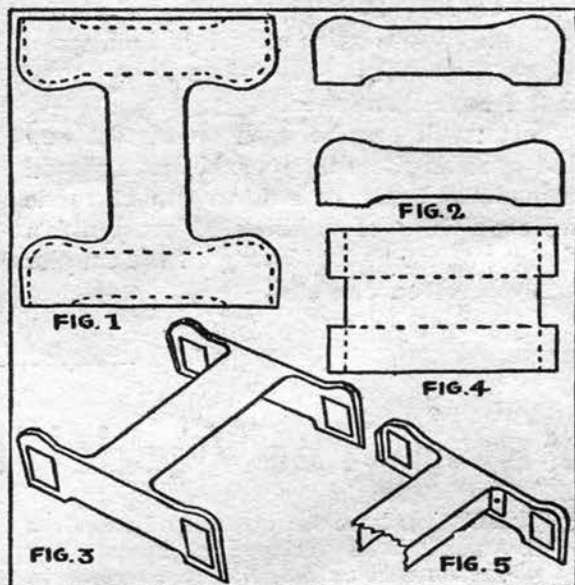

would save a lot of trouble, but I am one of those fans who prefer to make their own.

Now build the rest of the truck. Get some 18 gage sheet-iron. From this cut out as shown in Fig. 1 and bend along dotted lines. Make two forms out of material  $\frac{1}{4}$  inch thick, as shown in Fig. 2. By clamping into a vise, one plate on each side, along the dotted line of part indicated in Fig. 1, it is easy to hammer the edges to shape.

Mark out as shown, and cut the openings for your journal boxes. The finished product will look somewhat like Fig. 3. Cut another piece as shown in Fig. 4. Bend along the dotted lines and fasten by riveting crosswise underneath Fig. 3, as shown in Fig. 5. Make the journal boxes square

and the openings in the truck oblong in order to make room for springs above. Cut off heads of No. 6 round-head screws, leaving just enough of the screw for the spring to slip over. The slot in the screw will fit nicely on the upper part of the slot in the truck side.

No dimensions are given here. My main intention is to show you how easy it is to shape metal and make different parts. Moreover, each model railroader has his own idea as to the size he prefers. It would be easy to work out dimensions for any size model. Mine are all  $\frac{3}{4}$  inch scale. For smaller ones use sheet-iron lighter than what I have mentioned.

This truck can be used on almost any kind of rolling stock. Journal boxes should be made of brass, or a form can be made and cast them of babbitt. Next build a regular flat-car body, leaving off the coupler arrangement on one end.

Make the beams, etc., for underneath the same as those in real cars. They can be shaped easily over iron bars or forms which were first made to size. The rest of the car (except the plow end) is constructed similar to a box car, with the addition of a couple of windows and a cupola on top near the rear.

To make the plow end, first cut pieces out of cardboard, curve and shape them. Then cut them out of sheet iron, bend and fasten on. They can be made in two pieces and arranged either to plow both ways or to throw the snow to the right as for double-tracked lines. The latter, however, is more likely to jump the track. Some arrangement can be made for flangers, if one desires to clean the rail more closely. I will be glad to answer specific questions on this subject for any reader sending a self-addressed stamped envelope to my home at Colliersville, N. Y.

## The Model Trading Post

**F**REE listing here for anyone who desires to trade model railroad equipment, or tell about models or model clubs, or get in touch with other fans. Here are a few suggestions that apply to ALL sections of "Railroad Stories":

(1) If you write to several departments at the same time, use a separate sheet of paper for each, to avoid confusion. Write plainly in ink or double-spaced typewriting.

(2) Our May issue closed Feb. 15. Letters intended for June issue (out May 1) must be received by the Editor before March 15.

(3) Although we are glad to get photos from readers, space is limited; we use only a few every month. Don't be disappointed if yours are crowded out. Preference is given to unusual subjects that are exceptionally sharp and clear.

(4) When writing to strangers in your own country, use 2c reply postal card or enclose self-addressed stamped envelope.

MODEL railroaders who take their hobby seriously will be interested in two new books of real practical value, both issued by publishers of nationally known model magazines. One is "The Model Railroad Right of Way," which tells you how to build retaining walls, ramps, tunnels, signs, trees and many other realistic scenic effects. It is generously illustrated, cloth bound, overall size 9x12 in.; can be obtained at \$2.50 postpaid from the Modelmaker Corp., 98-R East Main St., Bay Shore, N. Y.

The other new book is "Simplified Trackwork for Model Railroad Builders," by W. K. Walthers and A. C. Kalmbach. Its 10 chapters give a fair idea of the scope of this volume: Planning the Layout, Track Design, Track Construction, Trigonometry Applied to Trackwork, Laying Out Circular Track, Laying Out a Switch (2 chaps.), Construction and Operation of a Switch Machine, Special Track Work, and Yard Layouts; 143 pages, good paper, cloth bound, illustrated with many photos and diagrams. Published by A. C. Kalmbach & Co., Wauwatosa, Wis., at \$2.50 postpaid in U. S. and Canada.

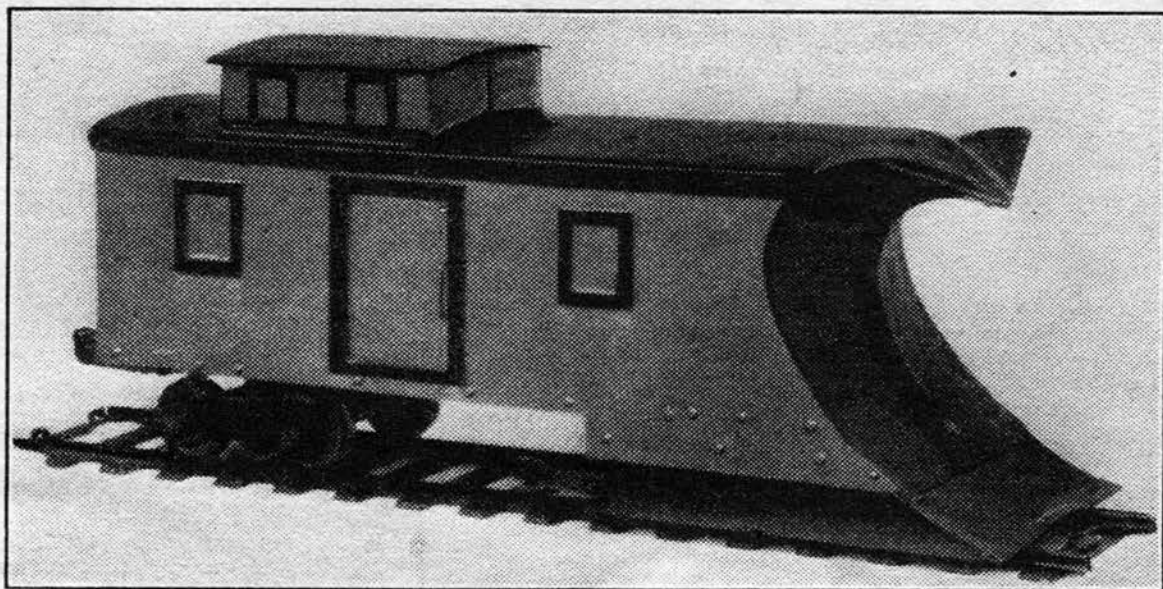

Wedge Snow Plow Model Built by Leonard Cooper, Described on Pages 139-140

**W**HY not specialize in constructive articles rather than descriptions of 5c and 10c models of junk? It would encourage the building of scale models. I know my models create a lot of interest and have made my neighbors train-minded.—K. M. Adams, 2924 26th Ave., San Francisco.

(EDITOR'S NOTE: The above idea is good, and we do print occasional articles on how to build intricate scale models. But most of our readers do not have the time, money or equipment to create such models; so we devote most of our available space to what they can afford.

I AM creating model street-car system with overhead trolley wire and slot system as in N. Y. City. Now building model of 600 series car of the Third Ave. Ry. Have finished floor, roof, bulkhead, and sides. I want to hear from  $\frac{1}{4}$  in. scale trolley fans; will send them photo of this car; which is  $\frac{1}{4}$  in. scale, except floor and roof,  $\frac{1}{2}$  in. scale. I will pay \$3 for Lionel 260E steam type loco without tender.—B. W. Brooks, 27 Parcot Ave., New Rochelle, N. Y.

I HAVE 26 old issues "Railroad Stories" and about 200 other magazines, good condition, to trade for narrow-gauge equipment.—Allen Narell, 244 Marcellus Rd., Mineola, N. Y.

WANTED: O gage trucks, couplers and rails, also power for locos; have several things to offer.—Russell Holcombe, 60 East St., Canton, Georgia.

WILL swap O gage Lionel engine No. 252E, A.F. engine, 12 sections track, 2 Lionel box cars No. 805 and coal car 803, for No. 219 standard-gauge derrick car or electrical or steam type engine or other st. gage equipment.—Edward Conklin, Jr., 194 Washington Ave., Roosevelt, N. Y.

I WILL trade 7 4-wheeled "Joy Line" O gage pass. cars for 8-wheeled O gage pass. or frt. cars, any make. Also will make reasonable offer for O gage wind-up engine (0-4-0, 2-4-0 or 4-4-0) with reverse lever and 8-wheeled tender.—Warren Stowman, 7444 Forrest Ave., E. Germantown, Philadelphia, Pa.

FOR trade or sale: Much Lionel O gage equipment, incl. No. 258 steam type loco with 8-wheeler tender, No. 820 searchlight car, No.

127 station, etc.; write for details.—L. Burtman, 260 Ft. Washington Ave., N. Y. City.

LET'S start a Salt Lake City Model Club. I have a lot of O gage equipment. Utah fans, please write.—Elmer Walton (age 14), 561 E. First South No. 1, Salt Lake City, Utah.

WANTED: Lionel O gage steam type engines and single-truck pass. and frt. cars; also track and switches.—F. W. Metzger, 200 Linden Ave., Riverton, N. J.

I HAVE 9 1934 issues "Railroad Stories" to trade for O gage electric switch or automatic signal.—B. Murphy, 832 54th St., Brooklyn, New York.

WANTED: Lionel No. 260 or 260E engine and tender, good condition; will pay cash or trade A.F. O gage loco 3030, baggage car 3000 and Pullman.—E. E. Roberts, Green River, Wyo.

WANTED: 2 narrow-gage electric track switches (not illuminated nor remote control) in good working order.—Richard Bloomfield, 525 12th St., Boone, Ia.

WHAT will you trade in railroad model equipment for a violin over 100 years old?—W. O. Engel, 3433 W. 44th, Cleveland, O.

I HAVE 50 old issues of various magazines, incl. "Railroad Stories," to trade for electric engine, track, switches, transformer, etc.—James Gilkerson, Burke, Gregory Co., S. D.

WHAT am I offered for following O gage electric equipment: 60 pieces of track, 45 degree crossover, 2 left-hand manually-controlled switches, Lionel ob. car No. 630, frt. cars 804-5-6, and caboose 807. I plan to build a  $\frac{1}{4}$  in. scale model road.—Chas. Gilbert, Box 146, Bartow, Fla.

WANTED: Second-hand O gage double-truck frt. car or caboose.—Robert MacHarg, 33 Wisconsin Ave., Somerville, Mass.

I HAVE a set of 5 vols. (500 pages each) on locomotive construction and appliances, railroad equipment, etc., published by Edward Kelly Co., Chicago—a real set for anyone build-

# PHOTOGRAPHS

## "COMMODORE VANDERBILT"

SIX EXCELLENT 8x10 PHOTOGRAPHS OF THE NEW YORK CENTRAL'S NEW STREAMLINED STEAM LOCOMOTIVE

(1) Head On. (2) Right Broadside. (3) Right Three Quarters. (4) Left Three Quarters. (5) Left Three Quarters with train. (6) Right Three Quarters with the De Witt Clinton Locomotive.

Price: 40c. each, 3 for \$1.00. Set of six \$2.00. Catalog of R.R. Photos ready for distribution April first.

LOCOMOTIVE PRINT IN COLORS

10x26 FULL COLOR PHOTO ENGRAVING OF THE N. Y. C. HUDSON TYPE NO. 5297. FOLDER GIVING HISTORY AND SPECIFICATIONS INCLUDED. 50c. (75c. in Canada).

### H. O. BAILEY STUDIOS

811 Cherry Street Philadelphia, Pa.



### Real Steam Locomotive

with electric heater driven by 2 steam cylinders. Self-starting.

12 inches long. Runs on "O" Gauge track—specially good on streamline track. Locomotive and special heavy transformer—complete price \$14.50

postpaid—same with remote control whistle \$17.65.

**MODELMAKERS**—Build your own steam locomotive or make your present model steam operated. For less than \$5.00 we can furnish cylinders, steam chest, electric heater, transformer coils and iron. Send 25c. for booklet with complete instructions, diagrams and technical information with price list of parts.

Steam Electric Co., 12 Henry St., Bloomfield, N. J.

## MODEL RAILROADERS

will find our new book

### "THE MODEL RAILROAD RIGHT OF WAY"

extremely useful. It tells you how to build retaining walls, ramps, tunnels, signs, trees, and many other scenic effects to make your model railroad realistic. It includes 31 pages of drawings and many illustrations. Overall size 6"x9". Cloth bound. PRICE \$2.50, postpaid.

Send for your copy to-day!

THE MODELMAKER CORPORATION  
98R East Main Street Bay Shore, N. Y.

## "The Flying Scotsman"

LOCOMOTIVE and 5 SLEEPING CARS

You can make perfect cardboard models from our COLOR CUTOUTS price 35c.

### Color Plates of "Cock o' the North"

2-3-2 Express L. N. E. Ry., "Princess Royal" 4-6-2 Express L. M. S. Ry., and "Merchant Taylors" 4,4,0 Express S. Ry. Suitable for framing. Price 35c. each, or 50c. the three.

25 Railway Postcards and 72 Railway Picture Stamps—Price 50 Cents

All of the above sent post free to any address in the U. S. A. or Canada for One Dollar.

F. MOORE, 3 Amen Corner, London E.C. 4, England

# Locomotive PHOTOGRAPHS

Engines of U. S. and of Canada

Send ten cents for list of prints or twenty cents for list and sample print. Cash only.

WARREN W. McCLEARY JR., P. O. Box 296, Lancaster, Pa.

## ARE YOU A MODEL RAILROADER?

If you are, you need my 76 page hand book and catalog. It gives complete information on getting started, track laying, signalling, control, etc. Also prices all parts, track, signals, control units, etc. A veritable encyclopedia of data; conversion tables, screw sizes, charts, etc.

Price only 25c postpaid.

W. K. WALTHERS 1574 W. Pierce Street  
Milwaukee, Wis.

ing scale models. Will trade for complete Lionel, Ives or A.F. standard-gage system, no junk; or railroad mags. 1914 to date, or good radio, camera, typewriter, No. 10 Gilbert erector set complete, or what have you?—Leon Walgren, 1325 River St., Canon City, Colo.

I WILL trade radio parts for O gage electric steam type locos and rolling stock, or track and switches.—E. E. Allison, 28 Summer St., Claremont, N. H.

I'D LIKE to hear from model and engine picture fans.—Ray Nelson (age 16), 15119 Raymond Ave., Gardena, Calif.

WILL buy A.F. or Lionel straight O gage track, good condition.—W. Ross Jones, 124 Jefferson Ave., Vandergrift, Pa.

WANTED: Lionel O gage track, switches, frt. cars, No. 262E steam type engine and accessories.—Robert Monaco, Box 383, Weston, Mass.

I WILL trade \$50 telegraph set and "Railroad Stories" Dec. '33-Dec. '34 incl. for good train electric set, or what have you?—J.H. Swalla, 3501 S. E. 14th Ave., Portland, Ore.

I HAVE pair O gage hand-operated switches, 14 sections curved track, No. 068 warning signal, automatic crossing gate with track SS, to trade for cars No. 815, 814, 813, all with double trucks, or what have you?—Chas. Teller, 272 Kingston Ave., Brooklyn, N. Y.

WHAT do you offer for the following: Ives narrow-gage electric engine, station transformer, 8 sections narrow-gage track, Lionel wind-up loco, 2 standard-gage locos, 36 sections standard-gage track, crossover, etc.?—Richard Bierman, R. 1, Box 196B, R.F.D., Hemet, Calif.

WANTED: Used O gage track, rolling stock, good condition.—C. F. Wood, Lyndonville, Vt.

I WILL trade Dorfan O gage derrick car No. 610 for Lionel O gage equipment. What have you?—Charles Brigham, 124 Northumberland Rd., Rochester, N. Y.

WILL exchange one pair new scale model switch castings, 4 ft. radius, for Lionel or Ives O gage trucks.—J. C. Loeffler, Box 397, Valley Stream, N. Y.

WANTED: A.F. steam type engine body No. 3194, 3308 or 3316, or Lionel steam type 258E body and frame. I will buy any of those items or will give in exchange a discontinued type Ives station.—Edwin Martin, 200 Union St., Holbrook, Mass.

WANTED: Obsolete tinsplate catalogs and equipment.—Louis Hertz, 640 Riverside Drive, New York City.

I HAVE 65 diagrams of frt. and pass. engines, 15 of tender trucks, and 85 diagrams of frt. cars, to trade or sell.—Frank Marsick, 1519 S. 59 Court, Cicero, Ill.

I WANT to buy standard-gage equipment.—Geo. W. Miller, Leaksville, N. C.

I HAVE ¼ in. scale model railroad, mostly toy equipment; would like to get new or used steam-propelled engine, good condition.—Bernard McDermott, 3811 Burt St., Omaha, Neb.

I AM building an electric model of S. P. MT-4 class, 4-8-2, ¼ in. scale.—John Cheney, P. O. Box 43, Berkeley, Calif.

WANTED: Ives hopper car No. 194; would like to hear from Ives fans.—P. Rolff, 105-16 93rd St., Ozone Park, N. Y.

FOR sale or trade in 116 size photos: ¼ in. scale model supplies, enough to build 2 frt. cars; 1933 "Modelmaker" in bound volume; 1934 "Modelmaker," loose issues.—Michael Pinkosky, 94 Houston St., Newark, N. J.

## ADVERTISING SECTION

I HAVE O gage Lionel equipment incl. No. 258 steam type loco and tender, No. 254 electric type loco, Pullman cars, 2 automatic train controls No. 078, to exchange for 260E steam type loco, distant control switches or No. 099 color light train control.—Harry Barrett, 49 Pleasant St., Concord, N. H.

I WILL trade 14 sections Lionel track, bumper 020, crossover 023, 1 pr. 4-wheel trucks with 3rd rail shoes, 2 prs. automatic couplers, Lionel catalogs 1927, '30 and '31, A.F. catalogs '26 and '29, and English model railroad catalog—all these for Lelley pass. car construction sets or Gilbert erector set N.Y.C. Hudson loco. Will make bigger offer for 1/4 in. scale steam type loco with electric drive, or an electric loco.—Hugo Forde, 2171 5th Ave., N. Y. City.

MODEL circus railroading has been my hobby since 1922, when I started building my outfit. It is now one of the very few complete models of the Ringling Brothers show. For the railroad I use Lionel equipment. Track surrounds 8 x 10 ft. lot, which will soon be enlarged with new siding set-up to permit real unloading, etc. Flats are from models of old wooden ones and new steel, the latest having aluminum painted sides. Two wagon loads (in which the show packs) fill a car. Besides flats, there are the stock car, bull cars, workmen's car, performers' sleeper, and owners' car "Sarhu," with diner or privilege car. The "Sarhu" follows Ringling custom of combining the owner's name with his wife's.

I also have other cars yet to be painted, incl. advance car, car to replace present owner's car, and another sleeper. Repainting and rebuilding keeps me busy. Many of my miniature wagons are models of Ringling-Barnum, John Robinson, Floto, Hagenbeck-Wallace, Sparks, etc. They are not exactly to scale, but the whole outfit certainly has the circus spirit.—Hugh Grant Rowell, North Tarrytown, N. Y.

I WISH to dispose of 9 cars, 2 1/4 in. gage. Of these, 6 are Lionel passenger cars: 2 No. 19 combination, 2 No. 190 ob., No. 1010 inter-urban type, and No. 18 Pullman. The other 3 are 3/4 in. scale box cars, W.P.19342, N.P. 2018, and N.P. 2107.—Clarence Ratzburg, 520 W. Fremont St., Apt. 4, Stockton, Calif.

### RAILROAD STORIES

280 Broadway, New York City

Readers' Choice

Stories, features and departments I like best in the April issue are:

1 \_\_\_\_\_  
 2 \_\_\_\_\_  
 3 \_\_\_\_\_  
 4 \_\_\_\_\_  
 5 \_\_\_\_\_  
 6 \_\_\_\_\_

Name \_\_\_\_\_  
 Occupation \_\_\_\_\_  
 Address \_\_\_\_\_

### PRINT YOUR OWN ENGINE PHOTOS

DIRECT FROM ANY NEGATIVE

on PAPER, CARDS, FABRIC, WOOD

Now, you can reproduce beautiful, permanent photographs (engines, etc.) on almost any surface: Ordinary paper, cards, shirts, ties (ALL FABRICS) Rubber, Wood, Porcelain, etc. TRANSFOTO, sensational, new!—does it in 4 minutes direct from plate or film negative! Harmless to negative! No DARK ROOM! RESULTS GUARANTEED \$1 COMPLETE TREATMENT FOR 400 PHOTOS Astonishingly simple. No special equipment or experience required. Send check or money-order for \$1, or pay postman upon arrival. Our MONEY-BACK GUARANTEE protects you! SADOR CO., 50 East Fordham Road, New York City



## A COMPLETE COURSE IN BOOK FORM MODERN DIESEL ENGINE PRACTICE by ORVILLE ADAMS

*Theory — Practical Applications — Operation — Maintenance — Repairs*

A COMPREHENSIVE TREATISE FOR STUDENT AND PRACTICAL ENGINEER Covering Fully all Types of Diesel Engines, their Operating Principles, their Numerous Modern Commercial, Automotive and Industrial Applications; Methods of Installation; Operating Costs; Types Best Suited for Various Tasks and Rules for Repair and Maintenance. Based on the Experience of the Leading Diesel Engine Manufacturers and Engineers on Servicing and the Diesel Locomotive. 656 Pages—359 Illustrations—Price \$8.00 Postpaid. MODEL MAKERS—Send for special circular of our book "Model Making," by Yates. 428 pages, 338 illustrations, price \$3.00. Send for FREE new 72 page Catalog.

THE NORMAN W. HENLEY PUB. COMPANY, DEPT. R.S., 2 WEST 45TH ST., NEW YORK CITY

## Get this Photo FREE (4" x 5" size) with each \$1.00 purchase this month only (no more than one to each customer)

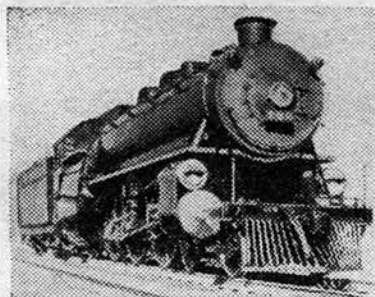

This engine is one of the first Conventional Streamlined Locomotives recently put in service by The Reading Co.

We now have the following photos of Streamlined Engines in the 3"x8" size at \$ for \$1.00:

N. Y. Central 4-6-4 "Commodore Vanderbilt" Pennsylvania R.R. 4-6-6-4 Elec. No. 4800  
 Reading Company 4-6-2 No. 108 (side view) Baltimore & Ohio 4-4-4 "Lady Baltimore"

### Did You Get Your Engine Picture Album Yet?

Most attractive and economical way of building up a collection of engine pictures. Beautiful large album, with 25 Loose-Leaf pages. Each page big enough for 8 of our new pictures. First page contains 8 Atlantic Coast Line engine photos neatly mounted with transparent corners. Other pages blank, except for railroad names printed at top. By filling album you get fine collection of 200 photos. Other pages may be added if needed. Send \$1.50 today (no stamps) for album and 8 good clear photos of same high standard we have been selling for years.

Builders' photos (album size) of engines on 25 U. S. roads now available, 60c. a set of 8. 32 Photo Corners 10 Cents Extra.

Send a dime (no stamps) for our complete catalogue listing over 1000 U. S. and Foreign Engine Photos.

LOCOMOTIVE PHOTOGRAPH CO., BOX 6354 WEST MARKET ST. STA., PHILADELPHIA, PA.

*In answering advertisements it is desirable that you mention RAILROAD STORIES.*

# DIESEL POWER

## A COMING AMERICAN INDUSTRY

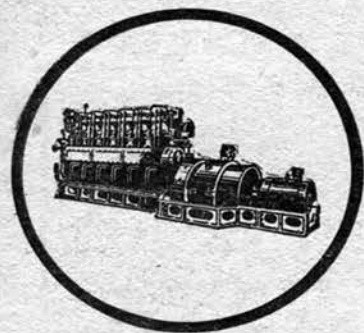

THE internal-combustion engine represents man's supreme triumph of machine power. Diesel engineers are in great demand. Many are acquiring necessary knowledge through spare-time study of this modern I. C. S. Course on Diesel engines. Free booklet!

### ELECTRICAL ENGINEERING

—A Great Industry with a Great Future



The new course in Electrical Engineering covers this fascinating field thoroughly. If you are just starting or are partly on the way to a real paying position in this industry, this new course brings the broader knowledge necessary for advancement. The coupon brings complete information.

### MECHANICAL ENGINEERING

—A Field with a Future



This course has meant advancement to hundreds of ambitious men, mechanics, draftsmen, blacksmiths, foundrymen, patternmakers, apprentices, and mechanical engineers—men who wanted to get ahead and to earn more money. You will find, as they have found, that enrolling for an I. C. S. Course is an investment in a Bigger Future.

## AUTOMOBILE EXPERTS

are always in demand

The rapid progress in manufacture and service of the modern automobile brings new opportunities to thousands of ambitious and forward-looking men. There's always a demand for trained men. The new I. C. S. Automobile Course will make you a trained man! The time to act is now.



## INTERNATIONAL CORRESPONDENCE SCHOOLS

"The Universal University"

BOX 2172-F, SCRANTON, PENNA.

★ Without cost or obligation, please send me a copy of your booklet, "Who Wins and Why," and full particulars about the subject before which I have marked X: ★

### TECHNICAL AND INDUSTRIAL COURSES

- |   |  |  |  |   |
|---|--|--|--|---|
| <input type="checkbox"/> Architect                                  | <input type="checkbox"/> Reading Shop Blueprints     | <input type="checkbox"/> Automobile Mechanic     | <input type="checkbox"/> Air Brakes                | <input type="checkbox"/> R. R. Signalman      |
| <input type="checkbox"/> Architectural Draftsman                    | <input type="checkbox"/> Telegraph Engineer          | <input type="checkbox"/> Plumbing                | <input type="checkbox"/> Highway Engineering       | <input type="checkbox"/> High Way Engineering |
| <input type="checkbox"/> Building Estimating                        | <input type="checkbox"/> Telephone Work              | <input type="checkbox"/> Heating                 | <input type="checkbox"/> Chemistry                 | <input type="checkbox"/> Pharmacy             |
| <input type="checkbox"/> Wood Millworking                           | <input type="checkbox"/> Mechanical Engineer         | <input type="checkbox"/> Sheet Metal Worker      | <input type="checkbox"/> Coal Mining Engineer      | <input type="checkbox"/> Navigation           |
| <input type="checkbox"/> Contractor and Builder                     | <input type="checkbox"/> Mechanical Draftsman        | <input type="checkbox"/> Steam Engineer          | <input type="checkbox"/> Civil Engineering         | <input type="checkbox"/> Air Conditioning     |
| <input type="checkbox"/> Structural Draftsman                       | <input type="checkbox"/> Machinist                   | <input type="checkbox"/> Steam Electric Engineer | <input type="checkbox"/> Surveying and Mapping     | <input type="checkbox"/> Boilermaker          |
| <input type="checkbox"/> Structural Engineer                        | <input type="checkbox"/> Toolmaker                   | <input type="checkbox"/> Refrigeration           | <input type="checkbox"/> Textile Overseer or Supt. | <input type="checkbox"/> Cotton Manufacturing |
| <input type="checkbox"/> Development and Protection of New Products | <input type="checkbox"/> Heat Treatment of Metals    | <input type="checkbox"/> R. R. Locomotives       | <input type="checkbox"/> Woolen Manufacturing      | <input type="checkbox"/> Agriculture          |
| <input type="checkbox"/> Electrical Engineer                        | <input type="checkbox"/> Bridge Engineer             | <input type="checkbox"/> R. R. Section Foreman   | <input type="checkbox"/> Fruit Growing             | <input type="checkbox"/> Poultry Farming      |
| <input type="checkbox"/> Electric Lighting                          | <input type="checkbox"/> Bridge and Building Foreman | <input type="checkbox"/> Gas Engines             | <input type="checkbox"/> Diesel Engines            | <input type="checkbox"/> Radio                |
| <input type="checkbox"/> Welding, Electric and Gas                  | <input type="checkbox"/> Gas Engines                 | <input type="checkbox"/> Diesel Engines          | <input type="checkbox"/> Aviation Engines          | <input type="checkbox"/> Marine Engineer      |

### BUSINESS TRAINING COURSES

- |  |   |   |  |
|--|---|---|--|
| <input type="checkbox"/> Business Management   | <input type="checkbox"/> C. P. Accountant | <input type="checkbox"/> Service Station Salesmanship | <input type="checkbox"/> Railway Mail Clerk    |
| <input type="checkbox"/> Office Management     | <input type="checkbox"/> Bookkeeping      | <input type="checkbox"/> First Year College           | <input type="checkbox"/> Grade School Subjects |
| <input type="checkbox"/> Industrial Management | <input type="checkbox"/> Secretarial Work | <input type="checkbox"/> Business Correspondence      | <input type="checkbox"/> High School Subjects  |
| <input type="checkbox"/> Traffic Management    | <input type="checkbox"/> Spanish          | <input type="checkbox"/> Lettering Show Cards         | <input type="checkbox"/> College Preparatory   |
| <input type="checkbox"/> Accountancy           | <input type="checkbox"/> French           | <input type="checkbox"/> Stenography and Typing       | <input type="checkbox"/> Illustrating          |
| <input type="checkbox"/> Cost Accountant       | <input type="checkbox"/> Salesmanship     | <input type="checkbox"/> Civil Service                | <input type="checkbox"/> Cartooning            |
|  | <input type="checkbox"/> Advertising      | <input type="checkbox"/> Mail Carrier                 |  |

Name..... Age..... Address.....

City..... State..... Occupation.....

If you reside in Canada, send this coupon to the International Correspondence Schools Canadian, Limited, Montreal, Canada

# ANNOUNCING AMAZING TYPEWRITER BARGAIN

BRAND NEW MODEL No. 5

REMINGTON  
PORTABLE

10¢ A DAY

MONEY BACK GUARANTEE



10 DAY  
FREE TRIAL  
OFFER

**FREE** EASY HOME  
TYPING COURSE

● Positively the greatest portable typewriter bargain ever offered! Now for the first time Remington, world-famous manufacturer, offers a NEW purchase plan... only 10¢ a day buys this latest model machine! Not a used or rebuilt typewriter. Not an incomplete machine. A beautiful brand new regulation Remington Portable. Standard 4-row keyboard; Standard width carriage; margin release on keyboard; back spacer; automatic ribbon reverse; every essential feature found in standard typewriters!

**Money making opportunities always open**

Hundreds of jobs are waiting for people who can type. A typewriter helps put your ideas on paper in logical, impressive form, helps you write clear, understandable sales reports, letters, articles, or stories. A Remington Portable has started many a young man and woman on the road to success.



**A Gift for Every Member of the Family**

If you want a gift for birthday, Christmas, or graduation... one that Father, Mother, Sister or Brother will use and appreciate for years to come... give a Remington Portable. It's the one gift that can be used with both pleasure and profit by every member of the family.

**ACT...WHILE LOW PRICE  
HOLDS GOOD!**

New wage scales in our own factories, and in the factories of the companies which make our materials, point definitely to higher prices. Stocks of machines on hand make possible the present unbelievably low cash price on this machine. Everything points to higher prices. We cannot possibly guarantee this low price in the face of constantly rising costs in every one of our departments. So we say... "Act fast!"

**10 DAY FREE TRIAL OFFER**

You can try this machine for 10 days without risking one penny of your money. Not even shipping charges. Send for complete details on this most liberal offer. Get attractive new catalogue illustrating and describing the many Remington models available on unusually low terms. Clip coupon today!

**EVERY ESSENTIAL FEATURE  
found in Standard Machines**

Buying a typewriter isn't like buying a suit of clothes. Many Remington portables, seeing 10 years of hard service are still in active use. When you buy...buy a machine with every standard feature. The Remington No. 5 is the most compact and durable portable ever built...includes all essential standard typewriter features. This beautiful machine

represents the height of economy... unequalled economy in first cost... unequalled economy in service.

It is today the best value ever offered in typewriter history... and that statement comes from the company that has constantly made typewriter history. Buy now. It is a real bargain offer.

**Specifications...**

The Model 5 includes every essential feature found in standard typewriters. It has standard 4-row keyboard, complete visibility, Standard width carriage for long envelopes. Carriage return lever of exceptional design for easy and rapid opera-

tion, Margin release on the keyboard, Automatic ribbon reverse, Backspacer, Two color ribbon shift, Variable line spacer, Adjustable margin stops, Auto set Paragraph Key (one of the most useful features found on any typewriter). Weight 11 lbs., 13 oz. Furnished with Pica or Elite type.

**TYPING COURSE FREE**

When you get your new Remington No. 5, you will get with it... ABSOLUTELY FREE... a 10-page course in typing. It teaches the Touch System, speeds up work. It is simply written and well illustrated. Instructions are easy as A, B, C. Even a child can understand this method. A little study and the average person, child or grown-up, becomes fascinated. Follow this course during the 10-DAY FREE TRIAL OFFER that we give you on your typewriter. At the end of that time, you should be able to dash off letters faster than with pen and ink.



**CARRYING CASE FREE**

With every Remington No. 5, a FREE carrying case sturdily built of 3-ply wood. Covered with heavy DuPont fabric. Top is removed in one motion, leaving machine firmly attached to base. Can be used anywhere... on knees, in chairs, on trains.



Remington Rand Inc., Dept. 145-4, Buffalo, N. Y.

Please tell me how I can buy a new Remington Portable typewriter for only 10¢ a day. Also enclose your new catalog.

Name \_\_\_\_\_  
Address \_\_\_\_\_  
City \_\_\_\_\_ State \_\_\_\_\_

**CLIP COUPON NOW**

REMINGTON RAND INC., DEPT. 145-4, BUFFALO, N. Y.

TO BANISH  
TIREDNESS QUICKLY...



GET A LIFT  
WITH A CAMEL!

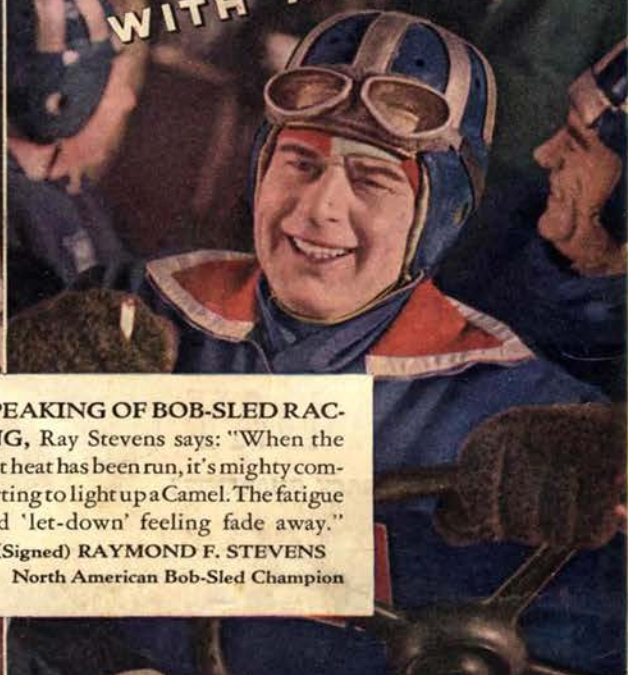

**SPEAKING OF BOB-SLED RACING,** Ray Stevens says: "When the last heat has been run, it's mighty comforting to light up a Camel. The fatigue and 'let-down' feeling fade away."

(Signed) **RAYMOND F. STEVENS**  
North American Bob-Sled Champion

"CAMELS RESTORE my 'pep' when I've used up my energy."  
(Signed) **JACK SHEA**  
Olympic Champion  
Speed Skater



**MASTER BUILDER:**  
"Camels give me new energy when I'm feeling tired and listless."  
(Signed)  
**FRAZIER PETERS**

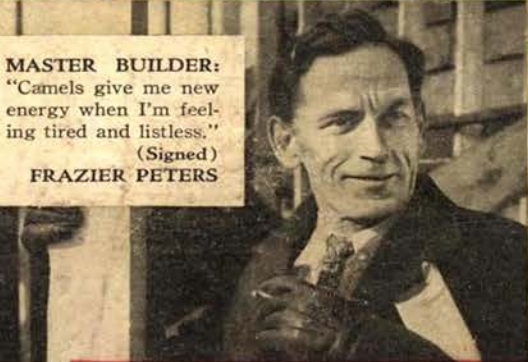

**COLLEGE GIRL:** "When I'm tired, a Camel makes me feel fresher, more alert."  
(Signed)  
**MARGUERITE OSMUN**



**LISTEN IN** 

Walter O'Keefe, Annette Hanshaw, Glen Gray's Casa Loma Orchestra over coast-to-coast WABC-Columbia Network.

**TUESDAY**

10:00 p.m. E. S. T.  
9:00 p.m. C. S. T.  
8:00 p.m. M. S. T.  
7:00 p.m. P. S. T.

**THURSDAY**

9:00 p.m. E. S. T.  
8:00 p.m. C. S. T.  
9:30 p.m. M. S. T.  
8:30 p.m. P. S. T.

**MORE EXPENSIVE TOBACCOS  
IN CAMELS..**



"Camels are made from finer, MORE EXPENSIVE TOBACCOS - Turkish and Domestic - than any other popular brand."

(Signed)  
R. J. REYNOLDS TOBACCO COMPANY  
Winston-Salem, North Carolina

**Camel's Costlier Tobaccos never get on your Nerves!**

Copyright, 1935  
R. J. Reynolds Tobacco  
Company  
Winston-Salem, N. C.